

OSA 500 B

Split System Outdoor Unit

Installation & Maintenance

GENERAL

OSA 500 B - A general designation for outdoor unit
OSA 500CB - Outdoor unit, cooling only version
OSA 500RB - Outdoor unit, reverse cycle version

The OSA 500 B outdoor unit is a twin system that provides the facility for capacity control (staging) or staggered starting.

Alternatively, the OSA outdoor unit can be connected to two indoor units of half capacity, controlled by a single thermostat. Four indoor units of one quarter capacity, i.e. two pairs connected in tandem, is also an option. In either case, refer to **temperzone** engineering for wiring details.

This OSA 500 B Outdoor Unit must be installed in accordance with all national and local safety codes.

Combinations

One OSA 500 B with one ISD 500QB
 One OSA 500 B with two ISD 250Q
 One OSA 500 B with four ISD 125Q

INSTALLATION

Positioning

Refer to dimension diagram below for minimum clearances. Fasten the unit down to a firm flat horizontal base using the four holes provided in the mounting rails.

When the unit is being installed on a roof it is recommended that the unit is installed on a substantial structure with vibration isolating springs beneath the unit. These springs are not supplied with the unit.

Drains

Four drain holes are provided in the base of the unit for the release of condensate and/or rain water. For a totally drip free installation mount the unit in a separate drain tray.

Coil Protection

Coil protection guards are available as an optional extra.

OPTIONAL FAN SPEED CONTROLLER

Fit a head pressure fan speed controller where cooling is required in below 20°C ambient conditions for long periods of time. An electronic HP Fan Speed Controller (8 amp) is available from **temperzone**. One is required for each of the two systems.

REFRIGERATION PIPING

General

The OSA 500 B is shipped with a holding charge of refrigerant. The matched indoor unit is shipped with a holding charge of nitrogen. OSA 500 B units have two flare and two brazed pipe connections.

Recommended Pipe Sizes

Suction pipe (x2) : 28 mm OD
 Liquid pipe (x2) : 16 mm OD

Line Lengths

For line lengths in excess of 50 m, contact the manufacturer's nearest sales office for additional details on piping requirements. Maximum extended line length is 70 m/sys.

Dimensions (mm)

OSA 500 B

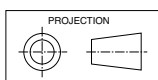

Not to Scale

Net Weight

OSA 500CB 394 kg
 OSA 500RB 404 kg

Point loads are approximately 100 kg at each corner.

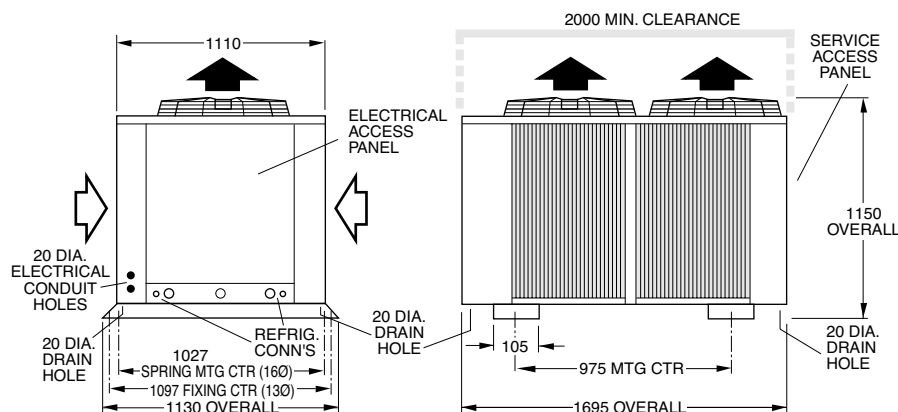
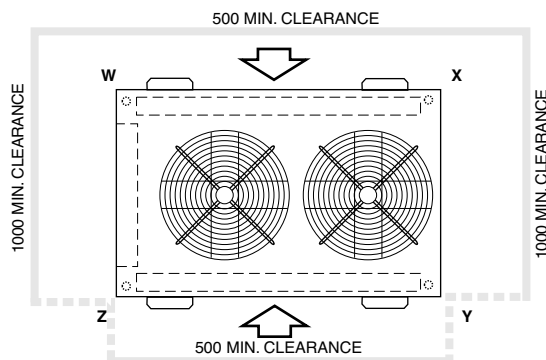

Height Separation Limits

Outdoor Unit above Indoor Unit : 18 m
 Outdoor Unit below Indoor Unit : 12 m

Vertical Risers

If the outdoor unit is to be installed above the indoor unit, then the suction riser should be trapped at the bottom of the vertical rise and then again at 5 m (maximum) intervals. This is to ensure oil return to the compressor. The trap to be a 'swan neck' curve in the pipe, with no change in the pipe size.

Piping

1. Use clean sealed refrigeration grade piping.
 2. Cut pipe with a pipe cutter ONLY.
 3. Use long radius bends (2 x pipe dia.).
 4. Insulate the suction (gas) line and seal all insulation joints.
 5. Filter dryer may be fitted in the liquid line (bi-flow type on reverse cycle systems).
 6. Include a process point on the interconnecting pipework.
 7. Ensure open pipe ends are sealed until the final connection is made.
 8. Immediately before removing brazed pipe connection's seal, reduce holding charge between connection points and service valves to atmospheric pressure.
- Warning:** Failure to do so may cause injury.

Important

Do not connect System 1 to System 2.

Charging

The unit is supplied with a 1 kg of holding charge of refrigerant HCFC-22 (R22) per system. Add 6.5 kg of HCFC-22 per system to complete the base charge, then add 105 g per metre of pipework between indoor and outdoor units.

Procedure (per system):

1. Evacuate Indoor Unit and interconnecting pipework to a pressure of 500 microns and hold for 15 mins.
2. Add refrigerant via the Schraeder connection on the smaller of the Outdoor Unit's two service valves.
3. Open the service valves at the Outdoor Unit to allow refrigerant to flow throughout the system.
4. Leak check all brazed and fitted joints.

IMPORTANT :

Step 9 of the 'Start Up Procedure' requires you to check that the superheat on the suction line (where it enters the Outdoor Unit) is between 3°C - 5°C on cooling cycle with an indoor air temperature in the range 21° - 27°C and outdoor air temperature in the range 24° - 35°C. If the conditions of the day do not allow this, use the heating cycle (on a reverse cycle unit) or other heat source to raise the indoor air temperature to about 24°C. Return to cooling cycle and blank off the outdoor coil to raise the head pressure to 240–280 psig (1750–1950 kPag). Alter charge up or down to establish correct superheat.

WARNING:

This unit is designed for use ONLY with the refrigerant HCFC-22. The use of other refrigerants is NOT authorised or approved by the manufacturer and may cause operational problems such as poor performance and efficiency, loss of capacity, degradation of materials and refrigerant leaks. **The use of flammable or explosive materials as a refrigerant creates the additional risks of fire and explosion which may result in property damage, personal injury or death.**

Oil Charge

For line lengths in excess of 30 m, *Emcarate RL22CF* polyol ester oil (or similar) should be added to the refrigerant at the rate of 30 ml/m of suction piping. **Note:** This oil absorbs moisture quickly if exposed to open air. Do not use mineral oil.

ELECTRICAL REQUIREMENTS

Electrical work must be done by a qualified electrician. The outdoor unit must be wired directly from a distribution board by means of a circuit breaker or H.R.C. fuse, and a mains isolator provided - preferably close to the Outdoor Unit.

Note: DO NOT USE REWIRABLE FUSES.

The OSA 500 B is provided with a 24V AC control circuit for a thermostat, on/off switch and/or time clock.

The control transformer 240V primary voltage is used for countries with 230-240V power supply. For countries with supply voltages 200-220V, change the primary voltage on the transformer to 208V.

OSA 500RB only - It is recommended electricians run a spare wire between Outdoor Unit and Indoor Unit(s) in case boost electric heat becomes a requirement. **Note:** Leave the wire unconnected until required.

Standard units are suitable for use with thermostats with either manual Heat/Cool selection or automatic changeover subject to the contact ratings of the thermostats.

A 24 hour power supply to the compressor crank case heaters is required, otherwise the warranty is void.

SYSTEM CHECK TESTS

1. Leave the remote switch in the off position and close the mains isolating switch.
A four hour delay period is required to allow the crankcase heater to drive any liquid refrigerant out of the compressor oil.
2. Check that the shipping blocks beneath each compressor have been removed and that each compressor is secure on its mounts.
3. Check that all fan motors are free running.
4. Check that the thermostat is correctly wired to the unit and is set at the desired temperature.
5. Check that the air filters, if any, have been correctly installed.
6. Check any supply air diffuser dampers are open.

START UP PROCEDURE

Check each system independently first before running complete system. Use the supplied Commissioning Sheet to help you complete the following procedure:

1. After the four hour delay period has expired switch on the unit.
2. Check the supply voltage.
3. Fit gauges and measure the suction and discharge pressures.
4. Check for correct rotation of the compressors. If rotation is incorrect a compressor will not pump, be noisy, and will draw minimal current. To correct motor rotation, change the phasing at the main power terminal.
5. Measure the current draw on each phase to the compressor motor and on each fan motor. Check all readings against the specified values - particularly the indoor fan amps if the unit is installed in a free blow application.

6. Test the operation of the high pressure safety control by switching off the outdoor unit's fan.
7. Test the operation of the reversing valve by running the unit in both the heating and cooling mode (OSA 500RB only).
8. Check that the air flow over the outdoor unit's coil is adequate and that the fan is running smoothly.
9. Check the superheat - refer charging procedure.
10. Check the indoor unit's fan belt tension after 20 mins of operation and adjust if necessary (refer Commissioning Sheet).
11. Check the supply air flow at each outlet.
12. Check the tightness of all electrical connections and sign the check label.
13. Touch up any outdoor unit paintwork damage to prevent corrosion.

MAINTENANCE

Weekly For First Four Weeks

1. Check indoor unit air filters (if fitted) and vacuum or wash clean as necessary.
2. Check condensate drain for free drainage.
3. Check compressor compartment for oil stains indicating refrigerant leaks.
4. Check tightness of electrical connections.

Three Monthly (or every 1200 hrs of operation)

Check the indoor unit's fan belt tension and adjust if necessary.

Six Monthly

1. Check the tightness of all fan and motor mountings.
2. Check the tightness of all electrical connections.
3. Check that fan motors are free running.
4. Check suction and discharge operating pressures.
5. Replace indoor unit air filters (if fitted).
6. Check condensate drain for free drainage.

Yearly

1. Check all refrigerant piping for chafing and vibration.
2. Check the operation of electric heaters if fitted.
3. Check air supply at all diffusers.
4. Check for excessive noise and vibration and correct as necessary.
5. Check for insulation and duct damage and repair as necessary.
6. Remove lint and dust accumulation from outdoor coil fins.
7. Touch up any outdoor unit paintwork damage to prevent corrosion.

NOTE

The manufacturer reserves the right to change specifications at any time without notice or obligation. Certified dimensions available on request.

This pamphlet replaces the previous issue no. 2663 dated 09/06.
Wiring rev's C & D .

Pipe Length Capacity Loss On Cooling Cycle Due to Pressure Drop

Note : Loss percentages are approximations only, due to piping variations. No allowance made for vertical piping.

Pipe Size (mm)		Equivalent Line Pipe Length (m)			
Liquid	Suction	10	20	30	40
16	28	1 %	2.5 %	3.5 %	5 %
16	35	-	1 %	1.5 %	2 %

Additional Pipe Length to allow per Bend		
Suction Pipe Size OD	28 mm	35 mm
Long 90° Radius (2 x pipe dia.)	0.61 m	0.76 m

OUTDOOR UNIT: OSA 500 C
 WITH INDOOR UNIT
 CAPACITIES - NET to AS/NZS 3823
 COOLING - kW 50.7
 ELECTRICAL INPUT @ 3Ph 400V ~ 50Hz kW 17.6
 COOLING - kW/kW 2.881
 E.E.R. (COOLING)

ELECTRICAL
 SUPPLY REQUIRED 3Ph 342-436V ~ 50Hz
 INCLUDING VOLTAGE FLUCTUATION LIMITS
 COMPRESSOR (3PH) RUN AMPS RATED CONDITIONS A/Ph 1.3 x2
 INDOOR FAN MOTOR FULL LOAD AMPS A/Ph 6.5
 INDOOR FAN MOTOR kW/MOTOR 3
 OUTDOOR FAN MOTOR (1PH) FULL LOAD AMPS A 3.3 x2
 OUTDOOR FAN MOTOR CAPACITOR MFD 12
 RUNNING AMPS (TOTAL) A/Ph 36
 RECOMMENDED EXTERNAL FUSE SIZE A/Ph 63
 WEIGHT-NETT OUTDOOR UNIT kg 370
 WEIGHT-NETT INDOOR UNIT kg 275
 REFRIGERANT - HCFC (R22) NOMINAL
 EACH SYSTEM HAS HOLDING CHARGE 1.0kg
 BASE CHARGE PER SYSTEM 7.5 kg PLUS 105 grams PER METRE LINE LENGTH
 BASED ON ø16mm OD LIQUID LINES & ø28mm OD GAS LINES

CB	CIRCUIT BREAKER	IFCC	INDOOR FAN CONTACTOR COIL
CCH	CRANKCASE HEATER	IFM	INDOOR FAN MOTOR
CM	COMPRESSOR MOTOR	IFOL	INDOOR FAN OVERLOAD
CMC	COMPRESSOR CONTACTOR	LP	LOW PRESSURE SWITCH
CMCC	COMPRESSOR CONTACTOR COIL	OFC	OUTDOOR FAN CONTACTOR
CMOL	COMPRESSOR OVERLOAD	OFCC	OUTDOOR FAN CONTACTOR COIL
C1R	COOLING 1 RELAY 24V CONTROL	OFM	OUTDOOR FAN MOTOR
C2R	COOLING 2 RELAY 24V CONTROL	PRC	PHASE ROTATION CONTROL
C2R	COOLING 2 RELAY 24V CONTROL	PRR	PHASE ROTATION RELAY
C2RC	COOLING 2 RELAY COIL 24V	PRRC	PHASE ROTATION RELAY COIL
DO	TIME DELAY 6.0 MIN, DELAY ON MAKE	TD	TIME DELAY 5.0 MIN, DELAY ON BREAK
FR	INDOOR FAN RELAY 24V CONTROL		
HP	HI PRESSURE SWITCH		
IFC	INDOOR FAN CONTACTOR	TK	CIRCUIT FOR OVERLOAD IN OUTDOOR FAN MOTOR

NOTE:
 CONTROL TRANSFORMER 240V PRIMARY VOLTAGE
 IS USED FOR COUNTRIES WITH 230V TO 240V
 POWER SUPPLY. FOR COUNTRIES WITH SUPPLY VOLTAGE
 OF 200V TO 220V CHANGE PRIMARY VOLTAGE TO 208V
 ON TRANSFORMER.

NOTE: CHECK WIRING BEFORE SWITCHING ON, INCORRECT CONNECTION WILL DAMAGE MOTORS.
 CLIENT WIRING Interconnections between units by client. Double insulated multi-core cable.

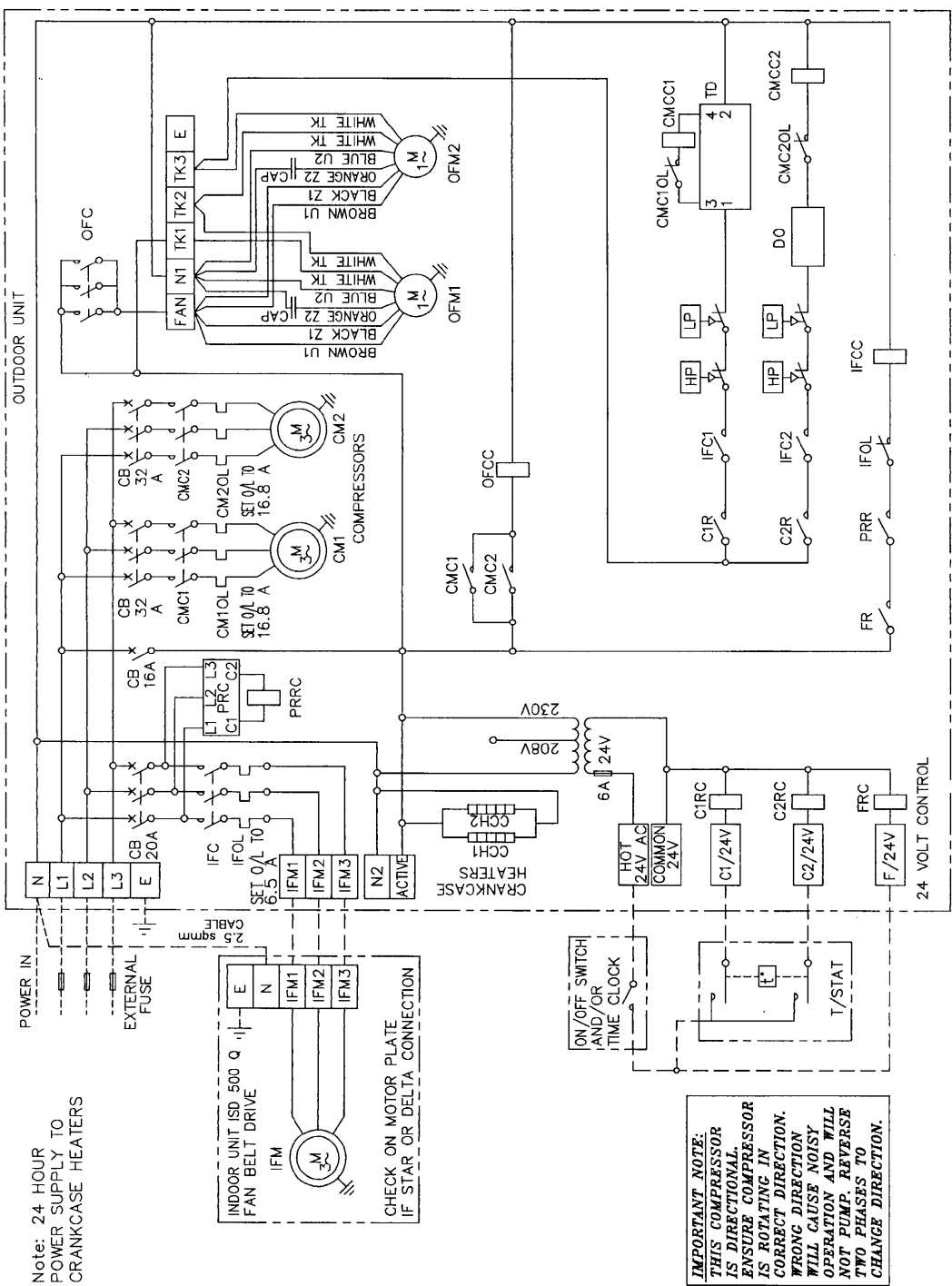

Title OSA 500 C
 WIRING SCHEMATIC

tempertzone

Drawn P.W. Date 22-03-02 Revision
 Scale 1:1 Drawing No. 327-694-006
 C

ISSUE	MODIFICATION	EC/N	DATE	APRVD	DRG SIZE	No.	DESCRIPTION	Mat.l	FINISH	ASSY No.
C	REFRIGERANT 7.5 (POE) WAS 6.2 (MIN OIL) N1464		16-01-07	ROD						
B	REFRIGERANT CHARGE CHANGE TO ESTER OIL N1417		07.09.06	B.P						
A	CHANGED TO NEW AS/NZS 3823 STANDARD. PHASE WIRE COLOURS REMOVED. 930		05-05-03	D.A.B.						

Programmed by

PLOTTED 16-01-07
 ©tempertzone ltd 2006

OUTDOOR UNIT: — OSA 500 R
WITH INDOOR UNIT

CAPACITIES — NET to AS/NZS 3823

COOLING — kW 50.7
HEATING — REVERSE CYCLE kW 53.8
ELECTRICAL INPUT @ 3Ph 400V ~ 50Hz kW 17.6
COOLING — REVERSE CYCLE kW 16.5
E.E.R. (COOLING) kW/kW 2.881

ELECTRICAL

SUPPLY REQUIRED 3Ph 342-436V ~ 50Hz INCLUDING VOLTAGE FLUCTUATION LIMITS

COMPRESSOR (3Ph) RUN AMPS RATED CONDITIONS A/Ph 13 x2
INDOOR FAN MOTOR FULL LOAD AMPS A/Ph 6.5
INDOOR FAN MOTOR kW/MOTOR 3
OUTDOOR FAN MOTOR (1Ph) FULL LOAD AMPS A 3.3 x2
OUTDOOR FAN MOTOR CAPACITOR MFD 12
RUNNING AMPS (TOTAL) A/Ph 36
RECOMMENDED EXTERNAL FUSE SIZE A/Ph 63
RECOMMENDED EXTERNAL FUSE WITH OPTIONAL ELECTRIC HEAT 4 kW PER PHASE TOTAL 12 kW 80A

WEIGHT—NETT OUTDOOR UNIT kg 380
WEIGHT—NETT INDOOR UNIT kg 275

REFRIGERANT — HCFC (R22) NOMINAL

EACH SYSTEM HAS HOLDING CHARGE 1.0kg

BASE CHARGE PER SYSTEM 7.5 kg PLUS 105 grams PER METRE LINE LENGTH BASED ON ø16mm OD LIQUID LINES & ø28mm OD GAS LINES

BR BRIDGE RELAY HP HI PRESSURE SWITCH
BRC BRIDGE RELAY COIL IFC INDOOR FAN CONTACTOR
CB CIRCUIT BREAKER IFCC INDOOR FAN CONTACTOR COIL
CCH CRANKCASE HEATER IFM INDOOR FAN MOTOR
CM COMPRESSOR MOTOR IFOL INDOOR FAN OVERLOAD
CMC COMPRESSOR CONTACTOR LP LOW PRESSURE SWITCH
CMC1 COMPRESSOR CONTACTOR COIL LPR LOW PRESSURE RELAY
CMOL COMPRESSOR OVERLOAD LPRC LOW PRESSURE RELAY COIL
C1R COOLING 1 RELAY 24V CONTROL OFC OUTDOOR FAN CONTACTOR
C1RC COOLING 1 RELAY COIL 24V OFCC OUTDOOR FAN CONTACTOR COIL
C2R COOLING 2 RELAY 24V CONTROL OFM OUTDOOR FAN MOTOR
C2RC COOLING 2 RELAY COIL 24V PRC PHASE ROTATION CONTROL
DIC DE-ICE CONTACTOR PRR PHASE ROTATION RELAY
DICC DE-ICE CONTACTOR COIL PRRC PHASE ROTATION RELAY COIL
DIFC DE-ICE INDOOR FAN CONTACTOR RCV REVERSE CYCLE VALVE
DO TIME DELAY 6.0 MIN. DELAY ON MAKE TD TIME DELAY 6.0 MIN. DELAY ON BREAK
FR INDOOR FAN RELAY 24V CONTROL
FRC INDOOR FAN RELAY COIL 24V
HR HEATING RELAY 24V CONTROL TK CIRCUIT FOR OVERLOAD IN
HRC HEATING RELAY COIL 24V TK OUTDOOR FAN MOTOR

NOTE: TESTING OF DE-ICE SWITCH POSITION ON SWITCH DIP SWITCH 1 OFF TO ALLOW REPEATED DE-ICE CYCLES WITHOUT A 33 MINUTE DELAY. SWITCH DIP SWITCH 2 OFF TO FORCE A DE-ICE CYCLE. ALWAYS RETURN BOTH SWITCHES TO 'ON' POSITION FOR NORMAL OPERATION.

Title OSA 500 R
WIRING SCHEMATIC



temperzone

Drawn P.W-M Date 08-03-02 Drawing No. Revision
Scale $\frac{1}{2}$ 326-694-006 D

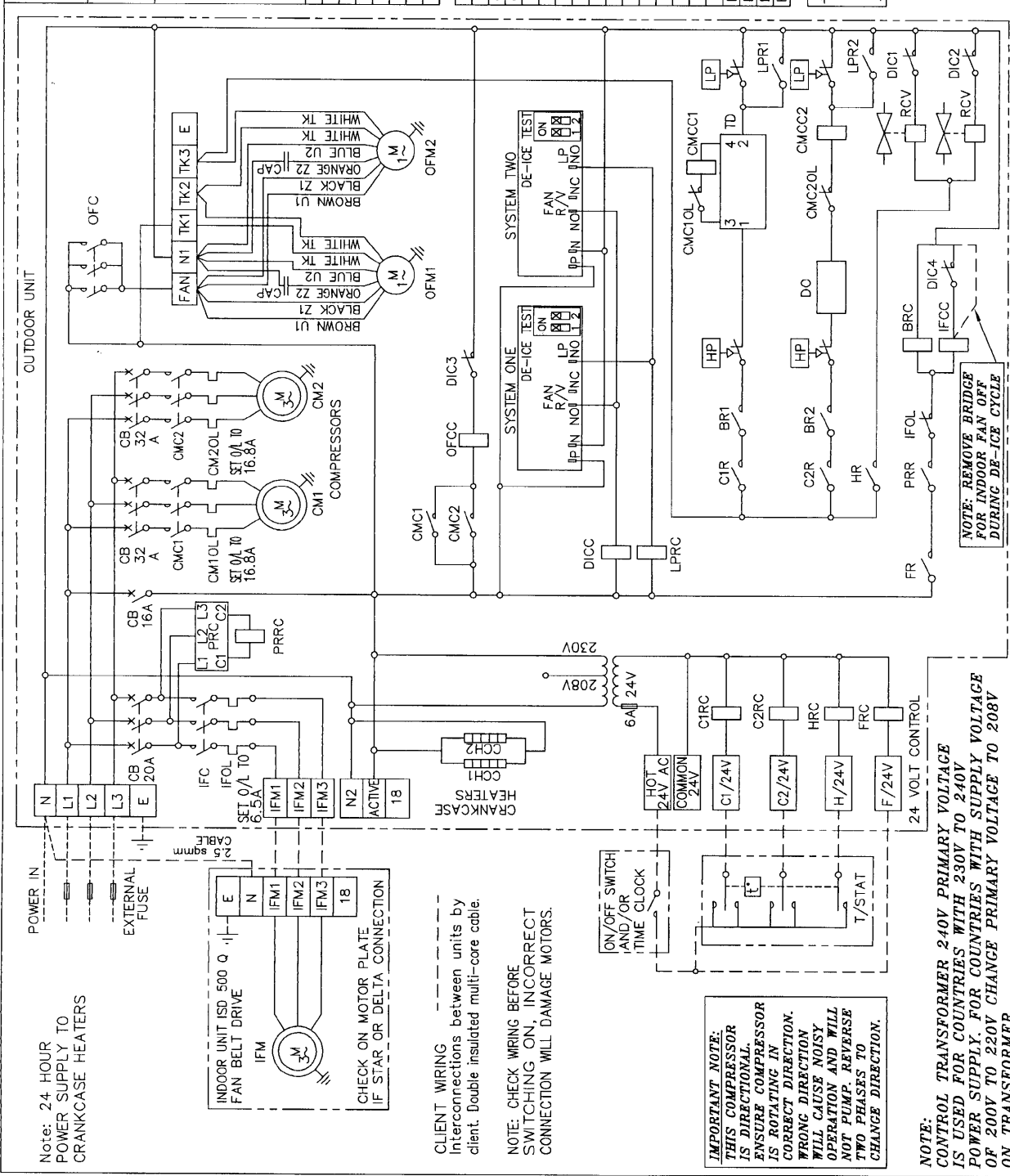

INDOOR UNIT ISD 500 Q. CHECK ON MOTOR PLATE IF STAR OR DELTA CONNECTION

CLIENT WIRING: Interconnections between units by client. Double insulated multi-core cable.

NOTE: CHECK WIRING BEFORE SWITCHING ON, INCORRECT CONNECTION WILL DAMAGE MOTORS.

IMPORTANT NOTE: THIS COMPRESSOR IS DIRECTIONAL. ENSURE COMPRESSOR IS ROTATING IN CORRECT DIRECTION. WRONG DIRECTION WILL CAUSE NOISY OPERATION AND WILL NOT PUMP. REVERSE TWO PHASES TO CHANGE DIRECTION.

NOTE: CONTROL TRANSFORMER 240V PRIMARY VOLTAGE IS USED FOR COUNTRIES WITH 230V TO 240V POWER SUPPLY. FOR COUNTRIES WITH SUPPLY VOLTAGE OF 200V TO 220V CHANGE PRIMARY VOLTAGE TO 208V ON TRANSFORMER.

DRG SIZE No. DESCRIPTION Mat. I. FINISH No. ASSY No.

ECN DATE APRVD

REFRIGERANT 7.5 (POE) WAS 6.2 (MIN OIL) N146416-07 ROD
REFRIGERANT CHARGE CHANGE TO ESTER OIL N14707.09.06 B.P

ISSUE MODIFICATION

PLOTTED 16-01-07
©temperzone ltd 2004