

OSA 184RKTGV (Digital c/w UC7 Controller)

Reverse Cycle R410A Split System Outdoor Unit

Installation & Maintenance

GENERAL

This OSA 184RKTGV Outdoor Unit must be installed in accordance with all national and local safety codes.

Options

1. TZT-100 Room Temperature Controller.
2. Signal Input for Controller 0–10V (ref p.2).
3. Anti-vibration mounts (rubber)
4. Drain connection adaptors - right angle.
5. Wall mounting brackets.

INSTALLATION

Positioning

Refer to dimension diagram below for minimum clearances.

Fasten the unit down to a firm flat horizontal base using the four holes provided in the mounting rails. To avoid transfer of vibration, mount the unit on the optional rubber mounts available from **temperzone**.

When the unit is being installed on a roof it is recommended that the unit is installed on a substantial structure with vibration isolating springs or rubber mounts (optional extra) beneath the unit. These items are not supplied with the unit.

Drain

Four drain holes are provided in the base. Three plastic bungs are supplied (loose) should you want to direct the condensate and/or rain water to one of the holes provided. Drain connection adaptors (25/13) are available as an optional extra.

REFRIGERATION PIPING

General

The OSA 184 is shipped with a refrigerant charge sufficient for a 10 m line length; refer wiring diagram specification table for amount. The matched indoor unit is shipped with a holding charge of nitrogen. OSA 184 units have shut-off service valves and swaged assemblies. Two loose pipe extensions are supplied to enable a choice of exit – side or rear; both require brazing.

Recommended Pipe Sizes

Suction pipe : 22 mm OD
Liquid pipe : 13 mm OD

Line Lengths

The standard unit allows for a line length up to 30 m. For line lengths between 30 m and 60 m, refer to **temperzone's Split Systems Installation Guide** (refer www.temperzone.biz/Technical Support). Refer also to *Oil Charge* overleaf.

Maximum line length when extended is 60m.

Height Separation Limits

Outdoor Unit above Indoor Unit : 20 m
Outdoor Unit below Indoor Unit : 20 m

Vertical Risers

If the outdoor unit is to be installed above the indoor unit, then the suction riser should be trapped at the bottom of the vertical rise and then again at 8 m (maximum) intervals. This is to ensure oil return to the compressor. The trap to be a 'swan neck' curve in the pipe, with no change in the pipe size.

Piping

1. Use clean sealed refrigeration grade piping and accessories designed specifically for R410A.
 2. Cut pipe with a pipe cutter ONLY.
 3. Use long radius bends (2x pipe dia.).
 4. Insulate the suction (gas) line and seal all insulation joints.
 5. Filter dryers are not required or recommended, however extreme care must be taken to keep the piping system dry.
 6. Include a process point in the interconnecting pipework.
 7. Ensure open pipe ends are sealed until the final connection is made.
 8. Immediately before removing brazed pipe connection's seal, reduce holding charge between connection points and service valves to atmospheric pressure.
- Warning:** Failure to do so may cause injury.

Charging

The unit is supplied with refrigerant HFC-410A (R410A) which is sufficient for 10 m of pipework between the indoor and outdoor units; refer wiring diagram specification table for amount. Add, or subtract, 60 g of HFC-410A per metre to suit the installed line length.

Procedure:

1. Evacuate Indoor Unit and interconnecting pipework to a pressure of 500 microns and hold for 15 mins.
2. Add refrigerant, if needed, via the Schraeder connection on the smaller of the Outdoor Unit's two service valves.

Dimensions (mm)

OSA 184RKTGV

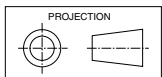

Not to Scale

Net Weight 205 kg

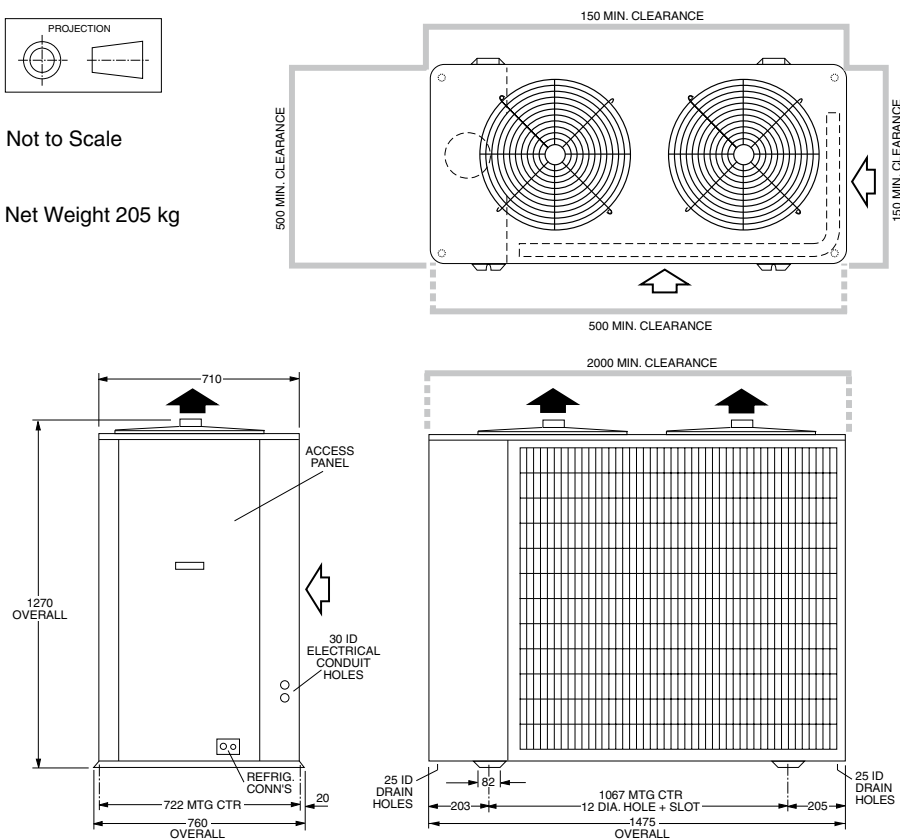

- Open the service valve at the Outdoor Unit to allow refrigerant to flow throughout the system.
- Leak check all brazed and fitted joints.

IMPORTANT :

Step 8 of the 'Start Up Procedure' requires you to check that the superheat on the suction line (where it enters the Outdoor Unit) is between 3°C – 5°C on cooling cycle with an indoor air temperature in the range 21° – 27°C and outdoor air temperature in the range 24° – 35°C. If the conditions of the day do not allow this, use the heating cycle (on a reverse cycle unit) or other heat source to raise the indoor air temperature to about 24°C and blank off the outdoor coil to raise the head pressure to 400 psig (2760 kPag). Alter charge up or down to establish correct superheat.

WARNING:

This unit is designed for use ONLY with the refrigerant HFC-410A. The use of other refrigerants is NOT authorised or approved by the manufacturer and may cause operational problems such as poor performance and efficiency, loss of capacity, degradation of materials and refrigerant leaks. **The use of flammable or explosive materials as a refrigerant creates the additional risks of fire and explosion which may result in property damage, personal injury or death.**

Oil Charge

For line lengths in excess of 40 m, Emkarate RL22CF polyolester oil (or similar) should be added to the refrigerant at the rate of 13 ml/m of suction piping. **Note:** Do not use mineral oil.

ELECTRICAL REQUIREMENTS

Electrical work must be done by a qualified electrician. The outdoor unit must be wired directly from a distribution board by means of a circuit breaker or H.R.C. fuse, and a mains isolator provided - preferably close to the Outdoor Unit.

Note: DO NOT USE REWIRABLE FUSES.

Standard units are suitable for use with thermostats with either manual Heat/Cool selection or automatic changeover subject to the contact ratings of the thermostats.

The matched ISD indoor unit is supplied with a 25m coil sensor lead that must be connected as per the wiring diagram.

The system is set up for the compressor to be controlled variably by:

- TZT-100 Controller (via modbus),
- 0-10V dc command via BMS modbus, or
- 0-10V dc command via a client supplied external controller.

If option 3 is chosen, then the optional Signal Input for Controller 0-10V is required (temperzone Part No. 201-000-386).

If a TZT-100 Controller is used then variable capacity control is automatically included and no additional wiring is required.

Note: The TZT-100 Controller can automatically switch the indoor fan off during de-ice, if selected, therefore no additional wiring is required to achieve this result.

A 24 hour power supply to the crankcase heaters is required, otherwise the warranty is void.

SYSTEM CHECK TESTS

- Leave the remote switch in the off position and close the mains isolating switch.
A four hour delay period is required to allow the crankcase heater to drive any liquid refrigerant out of the compressor oil.
- Check that all fan motors are free running.
- Check for correct rotation of the compressor. If rotation is incorrect the compressor will not pump and will draw minimal current. To correct motor rotation, change the phasing at the main power terminal.
- Check that the thermostat is correctly wired to the unit and is set at the desired temperature.
- Check that the indoor coil sensor lead is correctly wired to the unit.
- Check that the air filters, if any, have been correctly installed.
- Check any supply air diffuser dampers are open.

START UP PROCEDURE

Use the supplied Commissioning Sheet to help you complete the following procedure:

- Switch on the unit after the four hour delay period for the crankcase heater has expired.
- Check the supply voltage.
- Measure the current draw on the compressor motor and on each fan motor. Check all readings against the specified values - particularly the indoor fan amps if the unit is installed in a free blow application.
- Fit gauges and measure the suction and discharge pressures.
Important: Gauges must be designed specifically for use with R410A.
- Test the operation of the high pressure safety control by switching off the outdoor unit's fan.
- Test the operation of the reversing valve by running the unit in both the heating and cooling mode.
- Check that the air flow over the outdoor unit's coil is adequate and that the fan is running smoothly.
- Check the superheat - refer charging procedure.
- Check the supply air flow at each outlet.
- Touch up any outdoor unit paintwork damage to prevent corrosion.

UNIT CONTROLLER (UC7)

The Unit Controller provides system protection functions such as coil frost protection, de-icing, high head pressure and low suction pressure cut-out. It also protects against rapid cycling of the compressor(s) and loss of refrigerant. Various methods of head pressure control (or limiting) are employed in temperzone units. The particular method used varies from model to model, but is also handled by the Unit Controller. In combination, these features deliver optimised performance across a wide operating temperature range.

As a result of the UC's control of these inter-related functions, the outdoor fans may take some time to start rotating after each compressor start. They may also run on when the compressor stops. The fans will stop during a de-ice cycle. The speed will vary either smoothly, or in steps, in order to protect against excessively low or high head pressure.

Refer to UC7 Controller label on the unit or www.temperzone.biz for operation & fault diagnostics information.

MAINTENANCE

Weekly For First Four Weeks

- Check indoor unit air filters (if fitted) and vacuum or wash clean as necessary.
- Check condensate drain for free drainage.
- Check compressor compartment for oil stains indicating refrigerant leaks.
- Check tightness of electrical connections.

Six Monthly

- Check the tightness of all fan and motor mountings.
- Check tightness of electrical connections.
- Check that fan motors are free running.
- Check suction and discharge operating pressures.
- Replace indoor unit air filters (if fitted).
- Check condensate drain for free drainage.

Yearly

- Check all refrigerant piping for chafing and vibration.
- Check the operation of electric heaters if fitted.
- Check air supply at all diffusers.
- Check for excessive noise and vibration and correct as necessary.
- Check for insulation and duct damage and repair as necessary.
- Remove lint and dust accumulation from outdoor coil fins.
- Touch up all outdoor unit paintwork damage to prevent corrosion.

NOTE

The manufacturer reserves the right to change specifications at any time without notice or obligation. Certified dimensions available on request.

**Pipe Length Capacity Loss
On Cooling Cycle Due to Pressure Drop**

Note : Loss percentages are approximations only, due to piping variations. No allowance made for vertical piping.

Pipe Size (mm) Liquid	Pipe Size (mm) Suction	Performance Loss per additional 10m beyond first 5m.	Additional Pipe Length to allow per Suction Pipe Bend
			Long 90° Radius (2 x pipe dia.)
13	19	4.0 %	0.42 m
13	22	2.1 %	0.50 m

Capacities - Nett to AS/NZS 3823		OSA184RKTGV
Cooling -	kW	17.81
Heating - Reverse Cycle	kW	17.27
Electrical Input		
Cooling -	kW	5.50
Heating - Reverse Cycle	kW	4.92
E.E.R. (Cooling)	kW/kW	3.238
A.E.E.R. (Cooling)	kW/kW	3.220
Electrical		
Supply required	3Ph 342-436V ~ 50Hz	
Including voltage fluctuation limits		
Compressor type	Scroll	
Compressor (3Ph) run amps rated conditions	A/Ph	8
Oil type	Polyester (P.O.E.)	
Indoor Fan Motor (1Ph)	kW	1.25
Indoor fan motor (1Ph) Full load amps	A	8
Outdoor fan motor (1Ph) Full load amps	A	0.82 X 2
Outdoor motor capacitor (Built in fan motor)	MFD	6 X 2
Running amps (Total)	A/Ph	13.6/8.0/8.0
Max running amps (Total)	A	16.4/10.0/10.0
Control circuit breaker	A	10
24VCB 24 Volt circuit breaker	A	2
Unit Weight - Nett	Kg	205

Unit precharge (10 metre line length) 7.9Kg (R410A Refrigerant)
 Base charge unit 7.5kg Plus 60 grams per metre line length (based on dia 12.7 liq line & dia 22 gas line. Add additional oil (10ml per metre over 40 metre line length).

CAP	Capacitor	MFR	Med I/D Fan Relay
CCB	Control Circuit Breaker	MFR	Med I/D Fan Relay Coil
COH	CrankCase Heater	LFR	Low I/D Fan Relay
CM	Compressor Motor	LFR	Low I/D Fan Relay Coil
CMC	Compressor Contactor	LP	Low Pressure Control
CMCC	Compressor Contactor Coil	OFM	Outdoor Fan Motor
CR	Compressor Relay 24 V Control	PRC	Phase Rotation Control
CRC	Compressor Relay Coil 24v	PRR	Phase Rotation Relay
FRB	Fault Relay Board	PRC	Phase Rotation Relay Coil
HP	High Pressure Control	RCV	Reverse Cycle Valve
HR	Heating Relay	TFC	Triac Fan Controller
HRC	Heating Relay Coil	TR	Transformer
HFR	High I/D Fan Relay	UC7	Unit Controller Z
HFRC	High I/D Fan Relay Coil		
MV	Modulating Valve		

UC7 DIP switch settings	
DIP switch	On/Off ↓
2,4	On
1,3,5,6,7,8,9,10,11,12,13,14,15,16	Off

Temperature Sensor		
Sensor	Color	
DL	Discharge	Red
SL	Suction	Blue
AMB	Ambient	Black
DEI	Deice	Blue
OC	O/D Coil	Yellow
IC	I/D COIL	Yellow

Title
OSA 184RKTGV
C/W UC7 WIRING SCHEMATIC

TFC SW2 (DIP S/W) settings	
DIP	On/Off
1,2,3,4	Off

Plot date	27-03-12	Drawn E.B.A	27-03-12	Revision	A
©	temperzone Ltd	Approved		291-000-066	

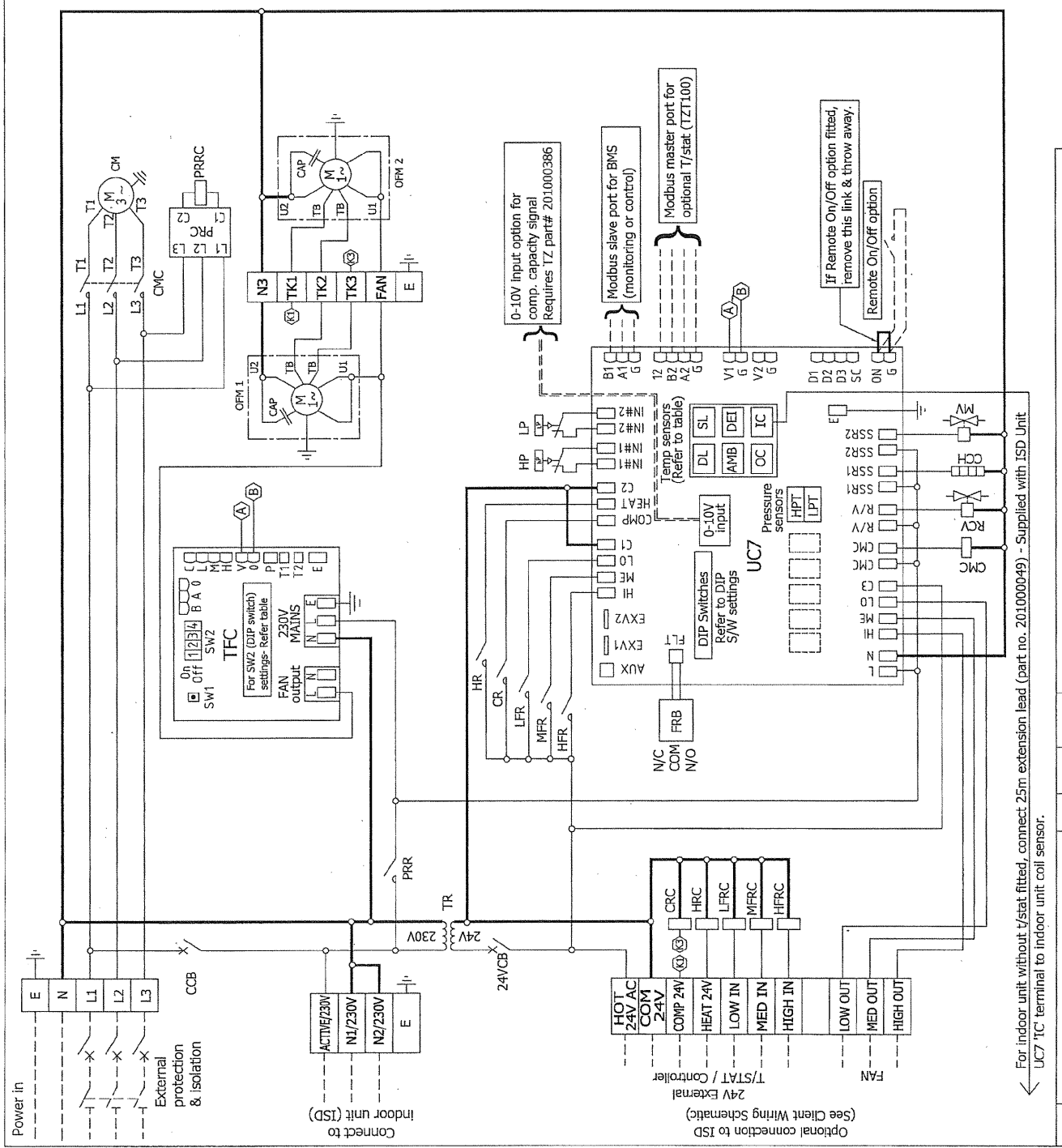

Optional connection to ISD (See Client Wiring Schematic)

For indoor unit without /stat fitted, connect 25m extension lead (part no. 201000049) - Supplied with ISD Unit
 UC7 'IC' terminal to indoor unit coil sensor.

Client wiring

ISSUE	MODIFICATION	ECN	DATE	APRVD
-------	--------------	-----	------	-------

Visit www.temperzone.biz for client wiring diagrams

This pamphlet replaces the previous
issue no. 3810 dated 03/13.
ISD indoor coil sensor, check tests.