

OPA 180

Packaged Roof Top Air Cooled Air Conditioner

Installation & Maintenance

GENERAL

OPA 180 - A general designation for the unit
OPA 180C - Outdoor unit, cooling only version
OPA 180R - Outdoor unit, reverse cycle version

This OPA 180 unit must be installed in accordance with all national and local safety codes.

OPTIONS (Field Fitted)

1. Filter box.
2. Electric heat kit.

FILTER BOX (Option)

The Filter Box is installed by unscrewing the return air spigot and replacing it with the Filter Box's filter-integrated galvanised spigot. The filter may be accessed from either side of this spigot. This new spigot has a depth of 135 mm, instead of 60 mm.

INSTALLATION

Positioning

Refer to dimension diagram for minimum clearances. If multiple units are to be placed side-by-side then allow at least 2 m between coil faces.

Mounting

Fasten the unit down to a firm flat horizontal base using the four holes provided in the mounting rails.

When the unit is being installed on a roof it is recommended that the unit is installed on a substantial structure with vibration isolating springs beneath the unit. These springs are not supplied with the unit.

Flexible duct connections are recommended between the supply and return ducts and the unit.

Condensate Drain

The condensate drain should be 'U' trapped outside the unit. The trap should have a vertical height of at least 50 mm. The drain should have a slope of at least 1 in 50 and must not be piped to a level above the unit drain pipe.

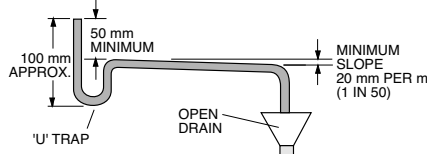

REFRIGERATION SYSTEM

General

The refrigeration system has been charged with 4.35 kg of HCFC-22 (R22) refrigerant. Tapping points are provided to measure discharge and suction operating pressures.

Compressor

The compressor is directional scroll type. The compressor lubricant is polyol ester oil (POE). Note, this oil absorbs moisture quickly if exposed to open air. On commissioning, the compressor must be checked for correct rotation (refer Start Up Procedure).

ELECTRICAL REQUIREMENTS

Electrical work must be done by a qualified electrician. The outdoor unit must be wired directly from a distribution board by means of a circuit breaker or H.R.C. fuse, and a mains isolator provided - preferably close to the unit.

Note: DO NOT USE REWIRABLE FUSES.

OPA 180R only - Standard units are suitable for use with thermostats with either manual Heat/Cool selection or automatic changeover subject to the contact ratings of the thermostats.

Refer to separate pamphlet for approved thermostats, or contact the manufacturer's nearest sales office.

A 24 hour power supply to the crankcase heaters is required, otherwise the warranty is void.

CHECK TESTS

1. Leave the remote switch in the off position and close the mains isolating switch.
A four hour delay period is required to allow the crankcase heater to drive any liquid refrigerant out of the compressor oil.
2. Check that all fan motors are free running.
3. Check that the thermostat is correctly wired to the unit and is set at the desired temperature.
4. Check that the air filters, if any, have been correctly installed.
5. Check any supply air diffuser dampers are open.

START UP PROCEDURE

Use the supplied Commissioning Sheet to help you complete the following procedure:

1. Switch on the unit after the four hour delay period for the crankcase heater has expired.
2. Check for correct rotation of the compressor. If rotation is incorrect the compressor will not pump, be noisy, and will draw minimal current. To correct motor rotation, change the phasing at the main power terminal.
3. Check the supply voltage.

4. Measure the current draw on the compressor motor and on each fan motor. Check all readings against the specified values - particularly the indoor fan amps if the unit is installed in a free blow application.
5. Fit gauges and measure the suction and discharge pressures.
6. Test the operation of the high pressure safety control by switching off the outdoor air fan.
7. Test the operation of the reversing valve by running the unit in both the heating and cooling mode (OPA 180R only).
8. Check that the motors are running smoothly.
9. Check the supply air flow at each outlet.
10. Touch up any outdoor unit paintwork damage to prevent corrosion.

OUTDOOR UNIT CONTROLLER (OUC) (OPA 180R only)

The Outdoor Unit Controller (OUC) includes a temperature sensing head pressure control which enables the system to compensate for outdoor ambient temperatures below 20°C on cooling cycle, and above 15°C on heating cycle. The OUC also has features which protect against icing or overheating of coils, rapid cycling of the compressor and loss of refrigerant charge.

If the outdoor unit fans take some time to begin rotating when the system is powered on, or they don't appear to be rotating appropriately while the compressor is running, consult the OUC label on the electrical box. If necessary, refer to **temperzone** for further diagnostic information.

MAINTENANCE

Weekly For First Four Weeks

1. Check indoor air filters (if fitted) and vacuum or wash clean as necessary.
2. Check condensate drain for free drainage.
3. Check compressor compartment for oil stains indicating refrigerant leaks.
4. Check tightness of electrical connections.

Six Monthly

1. Check the tightness of all fan and motor mountings.
2. Check tightness of electrical connections.
3. Check suction and discharge operating pressures.
4. Replace indoor unit air filters (if fitted).
5. Check condensate drain for free drainage.

Yearly

1. Check all refrigerant piping for chafing and vibration.
2. Check the operation of electric heaters, if fitted.
3. Check air supply at all diffusers.
4. Check for excessive noise and vibration and correct as necessary.
5. Check for insulation and duct damage and repair as necessary.
6. Remove lint and dust accumulation from outdoor coil fins.
7. Touch up any outdoor unit paintwork damage to prevent corrosion.

NOTE

The manufacturer reserves the right to change specifications at any time without notice or obligation. Certified dimensions available on request.

This pamphlet replaces the previous issue no. 2631 dated 09/06. Wiring revisions E & B.

Dimensions (mm)

OPA 180

Not to Scale

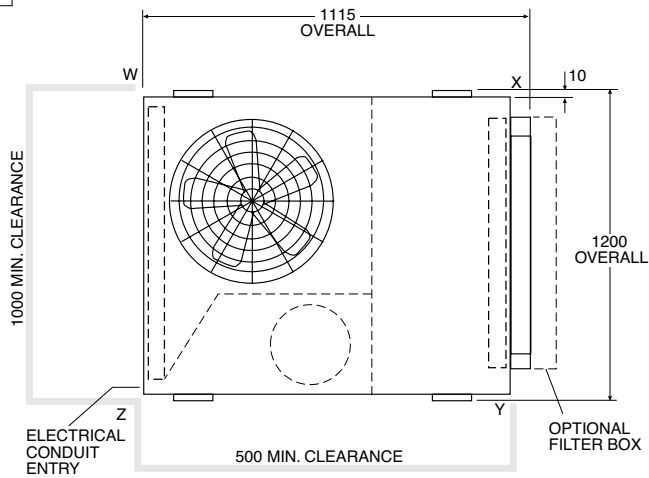
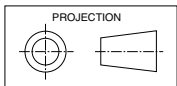

POINT LOADS (kg)				WEIGHT (kg)
W	x	Y	Z	
46	50	62	57	215

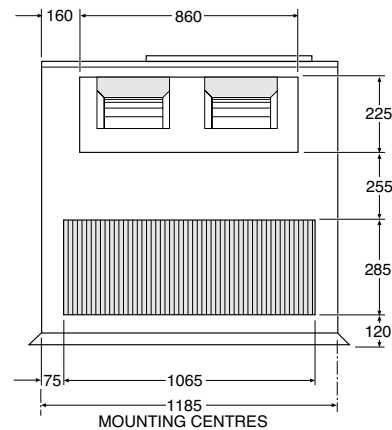
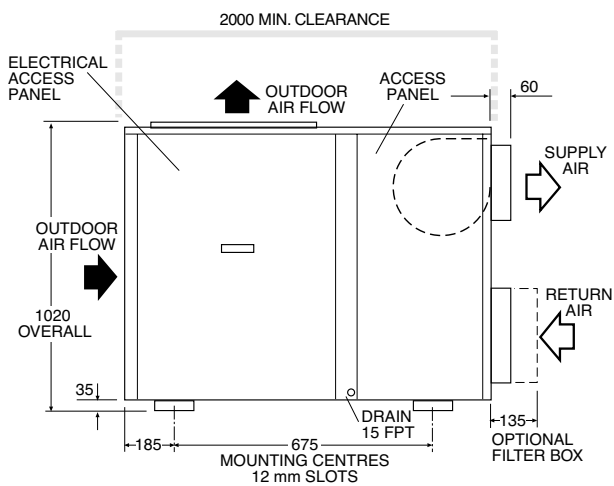

IMPORTANT NOTE:
 THIS COMPRESSOR IS DIRECTIONAL.
 ENSURE COMPRESSOR IS ROTATING IN CORRECT DIRECTION.
 WRONG DIRECTION WILL CAUSE NOISY OPERATION
 AND WILL NOT PUMP.
 REVERSE TWO PHASES TO CHANGE DIRECTION.

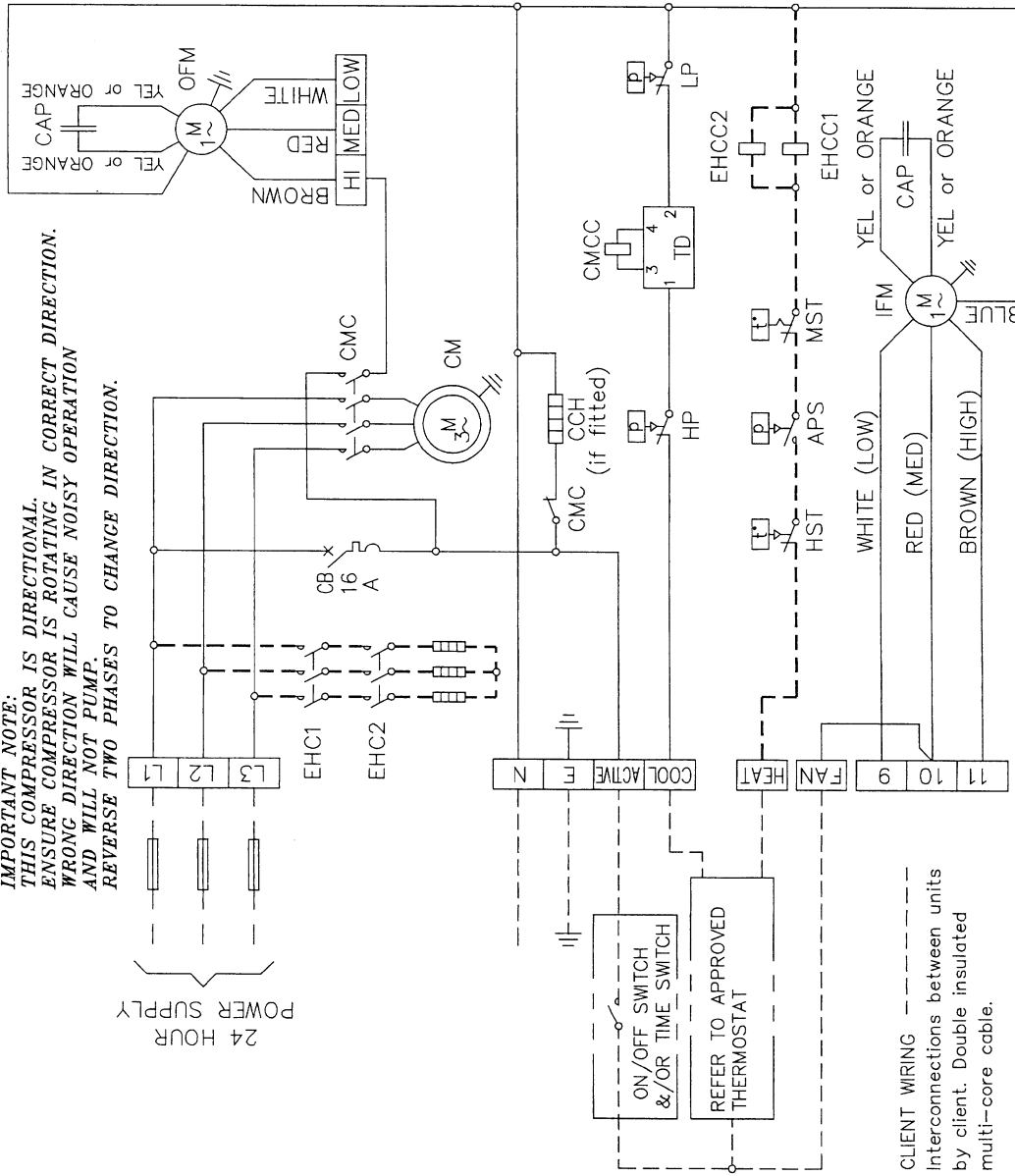

CLIENT WIRING -----
 Interconnections between units
 by client. Double insulated
 multi-core cable.

OPTIONAL ELECTRIC
 HEAT -----

CHECK WIRING BEFORE SWITCHING
 ON, INCORRECT CONNECTION WILL
 DAMAGE MOTORS

CAPACITIES - NET to AS/NZS 3823

COOLING -	kW	17.548
OPTIONAL ELECTRIC HEAT	kW	4.5
ELECTRICAL INPUT @ 3PH 400V ~ 50Hz		
COOLING -	kW	6.2
E.E.R. (COOLING)	kW/kW	2.830
ELECTRICAL		
SUPPLY REQUIRED 3PH 342-436V ~ 50Hz INCLUDING VOLTAGE FLUCTUATION LIMITS		
COMPRESSOR (3PH) RUN AMPS RATED CONDITIONS	A	8.5
COMPRESSOR (3PH) STARTING AMPS	A	12.0
INDOOR FAN MOTOR (1PH) FULL LOAD AMPS	A	6.3
INDOOR FAN MOTOR CAPACITOR	MFD	22.5
OUTDOOR FAN MOTOR (1PH) FULL LOAD AMPS	A	1.6
OUTDOOR FAN MOTOR CAPACITOR	MFD	8
RUNNING AMPS (TOTAL)		14/8/9
RECOMMENDED EXTERNAL FUSE SIZE	A	25
RECOMMENDED EXTERNAL FUSE SIZE C/W OPTION ELECTRIC HEAT	A	25
WEIGHT - NETT	kg	215
REFRIGERANT - HCFC (R22)	kg	4.35

APS	AIR PRESSURE SWITCH	EHCC1	ELECTRIC HEAT CONTACTOR COIL 1
CAP	CAPACITOR	EHCC2	ELECTRIC HEAT CONTACTOR COIL 2
CB	CIRCUIT BREAKER	HP	HIGH PRESSURE SWITCH
CCH	CRANK CSAE HEATER	HST	AUTO HIGH TEMP.SAFETY T/STAT
CM	COMPRESSOR MOTOR	IFM	INDOOR FAN MOTOR
CMC	COMPRESSOR CONTACTOR	LP	LOW PRESSURE SWITCH
CMCC	COMPRESSOR CONTACTOR COIL	MST	MANUAL HIGH TEMP.SAFETY T/STAT
EHC1	ELECTRIC HEAT CONTACTOR 1	OFM	OUTDOOR FAN MOTOR
EHC2	ELECTRIC HEAT CONTACTOR 2	TD	TIME DELAY 6 MINS

ISSUE	MODIFICATION	ECN	DATE	APRVD
E	REFRIGERANT 4.35 (POE) WAS 4.25 (MIN OIL) N1464 16-01-07 ROD			
D	ESTER OIL NEW REFRIG. CHARGE N1413 05-09-06 B.P			
C	OFM 4P NOW 6 POLES hi-spd.CAP 10 NOW 8 MFD, WAS 1.9A NOW 1.6A N1083 03-02-05 D.W.H			
B	CHANGED TO NEW NET AS/NZS 3823 STANDARD. CCH OPTION ADDED. 9.30 04-03-03 D.A.B			
A	OFM WAS 2 SPEED NOW 3 SPEED. WAS 12.5 NOW 10 MFD, WAS 3.8A NOW 1.9A N867 10-05-07 P.W-M			

DRG	No.	DESCRIPTION	Mat'l	FINISH	ASSTY
SIZE					No.

Programmed by
 PLOTTED
 16-01-07
 ©temperzone ltd
 2003

Title OPA 180 C WITH EL HEAT OPTION
 WIRING SCHEMATIC



temperzone

Drawn P.W-M	Date 26-09-01	Drawing No. 357-104-002	Revision
Scale	Asyd C.S		E

IMPORTANT NOTE:
 THIS COMPRESSOR IS DIRECTIONAL.
 ENSURE COMPRESSOR IS ROTATING IN CORRECT DIRECTION.
 WRONG DIRECTION WILL CAUSE NOISY OPERATION
 AND WILL NOT PUMP.
 REVERSE TWO PHASES TO CHANGE DIRECTION.

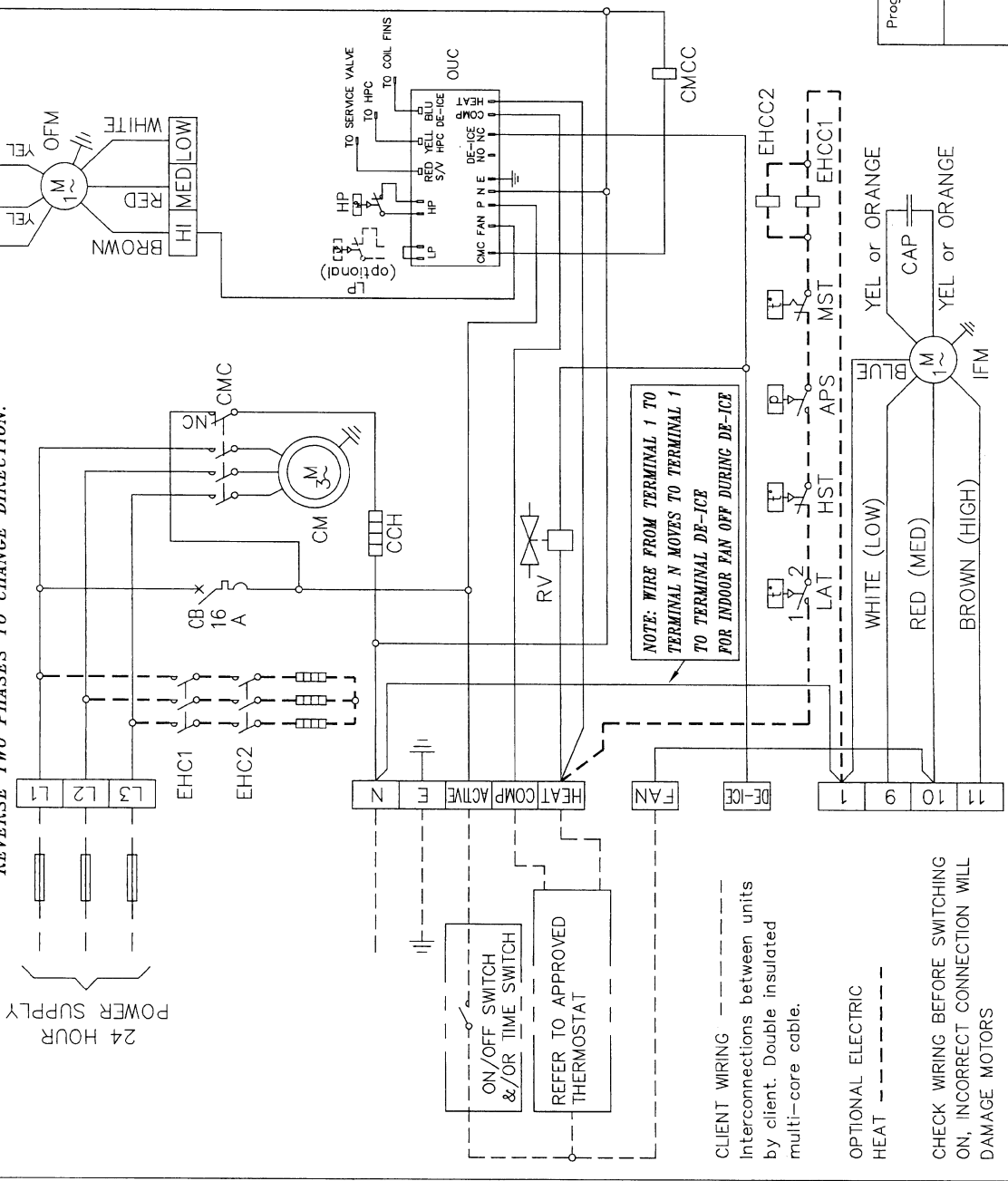

NOTE: WIRE FROM TERMINAL 1 TO TERMINAL N MOVES TO TERMINAL 1 FOR INDOOR FAN OFF DURING DE-ICE

CLIENT WIRING ---
 Interconnections between units by client. Double insulated multi-core cable.

OPTIONAL ELECTRIC HEAT - - - - -

CHECK WIRING BEFORE SWITCHING ON, INCORRECT CONNECTION WILL DAMAGE MOTORS

CAPACITIES - NET to AS/NZS 3823

COOLING -	kw	17.548
HEATING - REVERSE CYCLE	kw	18.8
OPTICAL ELECTRIC BOOST HEAT	kw	4.5
ELECTRICAL INPUT @ 3PH 400V ~ 50Hz		
COOLING -	kw	6.2
HEATING - REVERSE CYCLE	kw	5.5
E.E.R. (COOLING)	kw/kw	2.830

ELECTRICAL

SUPPLY REQUIRED 3PH 342-436V ~ 50Hz INCLUDING VOLTAGE FLUCTUATION LIMITS		
COMPRESSOR (3PH) RUN AMPS RATED CONDITIONS	A	8.5
COMPRESSOR (3PH) STARTING AMPS	A	12.0
INDOOR FAN MOTOR (1PH) FULL LOAD AMPS	A	6.3
INDOOR FAN MOTOR CAPACITOR	MFD	22.5
OUTDOOR FAN MOTOR (1PH) FULL LOAD AMPS	A	1.6
OUTDOOR FAN MOTOR CAPACITOR	MFD	8
RUNNING AMPS (TOTAL)		14/8/9
RECOMMENDED EXTERNAL FUSE SIZE	A	25
RECOMMENDED EXTERNAL FUSE SIZE C/W OPTION ELECTRIC HEAT	A	25
WEIGHT - NETT	kg	215
REFRIGERANT - HCFC (R22)	kg	4.35

APS	AIR PRESSURE SWITCH	EHCC2	ELECTRIC HEAT CONTACTOR COIL 2
CAP	CAPACITOR	HP	HIGH PRESSURE SWITCH
CB	CIRCUIT BREAKER	HST	AUTO HIGH TEMP.SAFETY T/STAT
CCH	CRANK CASE HEATER	IFM	INDOOR FAN MOTOR
CM	COMPRESSOR MOTOR	LAT	LOW AMBIENT T/STAT
CMC	COMPRESSOR CONTACTOR	LP	LOW PRESSURE SWITCH
CMCC	COMPRESSOR CONTACTOR COIL	MST	MANUAL HIGH TEMP.SAFETY T/STAT
EHC1	ELECTRIC HEAT CONTACTOR 1	OFM	OUTDOOR FAN MOTOR
EHC2	ELECTRIC HEAT CONTACTOR 2	RV	REVERSING VALVE
EHCC1	ELECTRIC HEAT CONTACTOR COIL 1		

Programmed by

temperzone

Title OPA 180 R WITH (O.U.C) & ELECTRIC HEAT OPTION - WIRING SCHEMATIC

Drawn D.A.B	Date 06-12-04	Drawing No.	Revision
Scale	As Dvd	456-104-002	B

PLOTTED
 16-01-07
 ©temperzone ltd
 2002

ISSUE	MODIFICATION	EC/N	DATE	APRVD	DRG SIZE	No.	DESCRIPTION	Mat'l	FINISH	ASSY No.
B	REFRIGERANT 4.35 (POE) WAS 4.25 (MIN OIL)	N1464	16-01-07	ROD						
A	ESTER OIL NEW REFRIG. CHARGE	N1413	05-09-06	B.P						