

# OSA 266R

## Reverse Cycle Split System Outdoor Unit

## Installation & Maintenance

### GENERAL

The OSA 266R Outdoor Unit is designed to be coupled with any of the following Indoor Units:

1. One ISD 266Q, or
2. Two ISD 127Q, or
3. One ISD 181 and one ISD 85Q.

This OSA 266R Outdoor Unit must be installed in accordance with all national and local safety codes.

### INSTALLATION

#### Positioning

Refer to dimension diagram below for minimum clearances. Fasten the unit down to a firm flat horizontal base using the four holes provided in the mounting rails.

When the unit is being installed on a roof it is recommended that the unit is installed on a substantial structure with vibration isolating springs beneath the unit. These springs are not supplied with the unit.

### Drains

Install the unit with a positive fall to the rear to ensure condensate and/or rain water drains away freely through the drain holes provided. For a totally drip free installation mount the unit in a separate drain tray.

### REFRIGERATION PIPING

#### General

The OSA 266R is shipped with a refrigerant charge sufficient for a 10 m line length. The matched indoor unit is shipped with a holding charge of nitrogen. OSA 266R units have one flare and one brazed pipe connection.

#### Recommended Pipe Sizes

Suction pipe : 28 mm OD  
Liquid pipe : 13 mm OD

### Line Lengths

For line lengths in excess of 30 m, fit a compressor crankcase heater to prevent liquid refrigerant condensing in the 'off' cycle. Refer also to *Oil Charge* overleaf. Maximum extended line length is 50 m.

### Height Separation Limits

Outdoor Unit above Indoor Unit : 12 m  
Outdoor Unit below Indoor Unit : 12 m

### Vertical Risers

If the outdoor unit is to be installed above the indoor unit, then the suction riser should be trapped at the bottom of the vertical rise and then again at 5 m (maximum) intervals. This is to ensure oil return to the compressor. The trap to be a 'swan neck' curve in the pipe, with no change in the pipe size.

### Piping Requirements

1. Use clean sealed refrigeration grade piping.
2. Cut pipe with a pipe cutter ONLY.
3. Use long radius bends (2x pipe dia.).
4. Insulate the suction (gas) line and seal all insulation joints.
5. Filter dryer may be fitted in the liquid line (bi-flow type on reverse cycle systems).
6. Include a process point in the interconnecting pipework.
7. Ensure open pipe ends are sealed until the final connection is made.
8. Immediately before removing brazed pipe connection's seal, reduce holding charge between connection points and service valves to atmospheric pressure.  
**Warning:** Failure to do so may cause injury.

### Dimensions (mm)

### OSA 266R

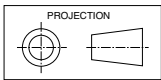

Not to Scale

Net Weight 226 kg

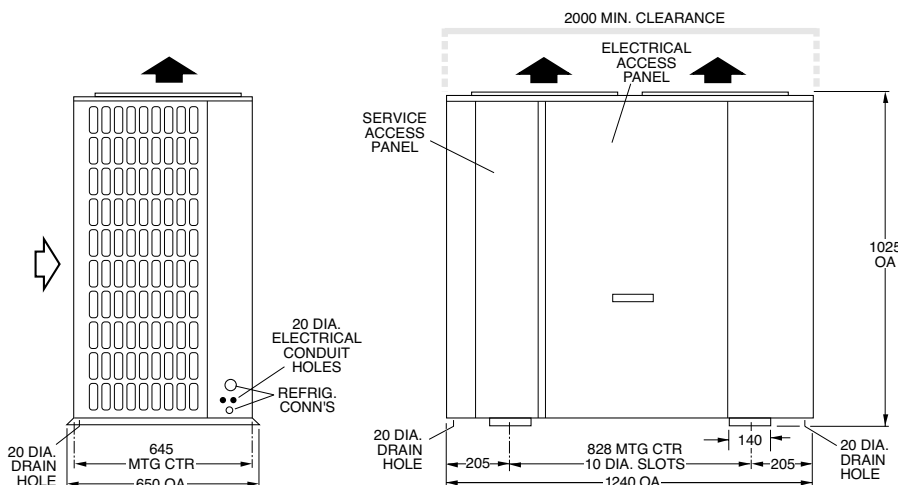
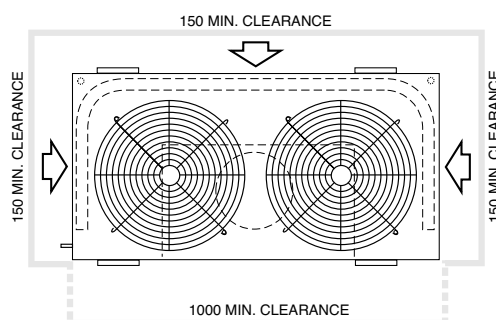

### Tandem Piping

When connecting two indoor units in tandem to the OSA 266R outdoor unit ensure the following:

1. Maximum line length specified for the outdoor unit must include both tandem legs.
2. Tandem legs must be as close as possible to equal, after leaving the common leg.
3. Ensure each 'T' joint connection is the same size as the common leg's pipe size, downsizing if necessary from there to each indoor unit.

### Charging

The unit is supplied with 7.5 kg of refrigerant HCFC-22 (R22) which is sufficient for up to 10 m of pipework between the indoor and outdoor units. Add 60 g of HCFC-22 per metre above 10 m.

## Charging (cont'd)

### Procedure:

1. Evacuate Indoor Unit and interconnecting pipework to a pressure of 500 microns and hold for 15 mins.
2. Add refrigerant, if needed, via the Schraeder connection on the smaller of the Outdoor Unit's two service valves.
3. Open the service valve at the Outdoor Unit to allow refrigerant to flow throughout the system.
4. Leak check all brazed and fitted joints.

### IMPORTANT :

Step 8 of the 'Start Up Procedure' requires you to check that the superheat on the suction line (where it enters the Outdoor Unit) is between 3°C - 5°C on cooling cycle with an indoor air temperature in the range 21° - 27°C and outdoor air temperature in the range 24° - 35°C. If the conditions of the day do not allow this, use the heating cycle (on a reverse cycle unit) or other heat source to raise the indoor air temperature to about 24°C and blank off the outdoor coil to raise the head pressure to 240–280 psig (1750–1950 kPag). Alter charge up or down to establish correct superheat.

### WARNING:

This unit is designed for use ONLY with the refrigerant HCFC-22. The use of other refrigerants is NOT authorised or approved by the manufacturer and may cause operational problems such as poor performance and efficiency, loss of capacity, degradation of materials and refrigerant leaks. **The use of flammable or explosive materials as a refrigerant creates the additional risks of fire and explosion which may result in property damage, personal injury or death.**

### Oil Charge

For line lengths in excess of 30 m, *Emcarate RL22CF* polyol ester oil (or similar) should be added to the refrigerant at the rate of 13 ml/m of suction piping. **Note:** Do not use mineral oil.

### ELECTRICAL REQUIREMENTS

Electrical work must be done by a qualified electrician. The outdoor unit must be wired directly from a distribution board by means of a circuit breaker or H.R.C. fuse, and a mains isolator provided - preferably close to the Outdoor Unit.

**Note:** DO NOT USE REWIRABLE FUSES.

It is recommended electricians run two spare wires between Outdoor Unit and Indoor Unit in case one, or both, of the following options becomes a requirement.

**Note:** Leave the wires unconnected until required.

*Option 1* - Indoor Fan Off During De-Ice.

*Option 2* - Electric Boost Heat.

Refer indoor unit's wiring diagram.

Standard units are suitable for use with thermostats with either manual Heat/Cool selection or automatic changeover subject to the contact ratings of the thermostats.

Refer to separate pamphlet for recommended thermostats, or contact the manufacturer's nearest sales office.

If a compressor crankcase heater is fitted, then a 24 hour power supply to the crankcase heaters is required, otherwise the warranty is void.

### SYSTEM CHECK TESTS

1. Leave the remote switch in the off position and close the mains isolating switch.  
A four hour delay period is required to allow the crankcase heater to drive any liquid refrigerant out of the compressor oil.
2. Check that all fan motors are free running.
3. Check for correct rotation of the compressor. If rotation is incorrect the compressor will not pump, be noisy, and will draw minimal current. To correct motor rotation, change the phasing at the main power terminal.
4. Check that the thermostat is correctly wired to the unit and is set at the desired temperature.
5. Check that the air filters, if any, have been correctly installed.
6. Check any supply air diffuser dampers are open.

### START UP PROCEDURE

1. Switch on the unit after the four hour delay period has expired.
2. Check the supply voltage.
3. Measure the current draw on the compressor motor and on each fan motor. Check all readings against the specified values - particularly the indoor fan amps if the unit is installed in a free blow application.
4. Fit gauges and measure the suction and discharge pressures.
5. Test the operation of the high pressure safety control by switching off the outdoor unit's fan.
6. Test the operation of the reversing valve by running the unit in both the heating and cooling mode.
7. Check that the air flow over the outdoor unit's coil is adequate and that the fan is running smoothly.
8. Check the superheat - refer charging procedure.
9. Check the supply air flow at each outlet.

### OUTDOOR UNIT CONTROLLER (OUC)

The Outdoor Unit Controller (OUC) includes a temperature sensing head pressure control which enables the system to run efficiently on cooling cycle at outdoor ambient temperatures below 20°C, and heating cycle above 15°C. The OUC also has features which protect against icing or overheating of coils, rapid cycling of the compressor and loss of refrigerant charge.

If the outdoor unit fans take some time to begin rotating when the system is powered on, or they don't appear to be rotating appropriately while the compressor is running, consult the OUC label on the electrical box. If necessary, refer to **temperzone** for further diagnostic information.

### MAINTENANCE

#### Weekly For First Four Weeks

1. Check indoor unit air filters (if fitted) and vacuum or wash clean as necessary.
2. Check condensate drain for free drainage.
3. Check compressor compartment for oil stains indicating refrigerant leaks.
4. Check tightness of electrical connections.

#### Six Monthly

1. Check the tightness of all fan and motor mountings.
2. Check tightness of electrical connections.
3. Check that fan motors are free running.
4. Check suction and discharge operating pressures.
5. Replace indoor unit air filters (if fitted).
6. Check condensate drain for free drainage.

#### Yearly

1. Check all refrigerant piping for chafing and vibration.
2. Check the operation of electric heaters if fitted.
3. Check air supply at all diffusers.
4. Check for excessive noise and vibration and correct as necessary.
5. Check for insulation and duct damage and repair as necessary.
6. Remove lint and dust accumulation from outdoor coil fins.
7. Touch up all outdoor unit paintwork damage to prevent corrosion.

### NOTE

The manufacturer reserves the right to change specifications at any time without notice or obligation. Certified dimensions available on request.

This pamphlet replaces the previous issue no. 2355 dated 04/04. Oil Charge.

## Pipe Length Capacity Loss

### On Cooling Cycle Due to Pressure Drop

**Note :** Loss percentages are approximations only, due to piping variations. No allowance made for vertical piping.

Pipe Size (mm)		Equivalent Line Pipe Length (m)			Additional Pipe Length to allow per Bend	
Liquid	Suction	10	20	30	Suction Pipe Size OD	28 mm
13	28	1.5 %	3.75 %	5 %	Large 90° Radius (2 x pipe dia.)	0.61 m

OUTDOOR UNIT: - OSA 266 R

WITH INDOOR UNIT	ISD 266
CAPACITIES - NET to AS/NZS 3823	
COOLING - REVERSE CYCLE	kW 25.16
HEATING - REVERSE CYCLE	kW 27.00
ELECTRICAL INPUT @ 3PH 400V ~ 50Hz	
COOLING -	kW 9.24
HEATING - REVERSE CYCLE	kW 7.93
E.E.R. (COOLING)	kW/kW 2.922
ELECTRICAL	
SUPPLY REQUIRED 3PH 342-436V ~ 50Hz INCLUDING VOLTAGE FLUCTUATION LIMITS	
COMPRESSOR (3PH) RUN AMPS RATED CONDITIONS	A/Ph 14.3
INDOOR FAN MOTOR (IPH) FULL LOAD AMPS	A 5 x2
INDOOR FAN MOTOR CAPACITOR	MFD 15 x2
OUTDOOR FAN MOTOR (IPH) FULL LOAD AMPS	A 0.9 x2
OUTDOOR FAN MOTOR CAPACITOR	MFD 6 x2
RUNNING AMPS (TOTAL)	A 25/14/14
RECOMMENDED EXTERNAL FUSE SIZE	A/Ph 40
ELECTRIC HEAT OPTION, 1.5 kW x3	A/Ph 6.6
RECOMMENDED EXTERNAL FUSE SIZE WITH OPTIONAL ELECTRIC HEAT	A/Ph 50
WEIGHT - NETT OSA 266R	208 kg

REFRIGERANT - HCFC (R22)  
 UNIT PRECHARGED (10 METRE LINE LENGTH) 7.5 kg  
 BASE CHARGE UNIT 6.9 kg PLUS 60 grams PER METRE LINE LENGTH  
 BASED ON LIQUID LINE #13 mm & GAS LINE #28 mm

CAP	CAPACITOR
CB	CIRCUIT BREAKER
CCH	CRANKCASE HEATER
CM	COMPRESSOR MOTOR
CMC	COMPRESSOR CONTACTOR
HP	HI PRESSURE SWITCH
IFM	INDOOR FAN MOTOR
LAT	LOW AMBIENT T/STAT
LP	LOW PRESSURE SWITCH
OFM	OUTDOOR FAN MOTOR
OUC	OUTDOOR UNIT CONTROLLER
RV	REVERSING VALVE

CHECK WIRING BEFORE SWITCHING ON, INCORRECT CONNECTION WILL DAMAGE MOTORS

CLIENT WIRING ---  
 Interconnections between units by client. Double insulated multi-core cable.

Consult Outdoor Unit Controller label for further details, or refer to Temperzone for fault diagnosis information.  
 Sensor Locations:  
 Red to service valve pipe pocket.  
 Yellow to coil return bend pocket.  
 Blue to bottom of coil in fins.

OSA 266 R WITH ISD 266  
 WIRING SCHEMATIC



tempertzone

Drawn P.W-M	Date 02-04-04	Drawing No. 426-544-002	Revision
Scale	1:1		

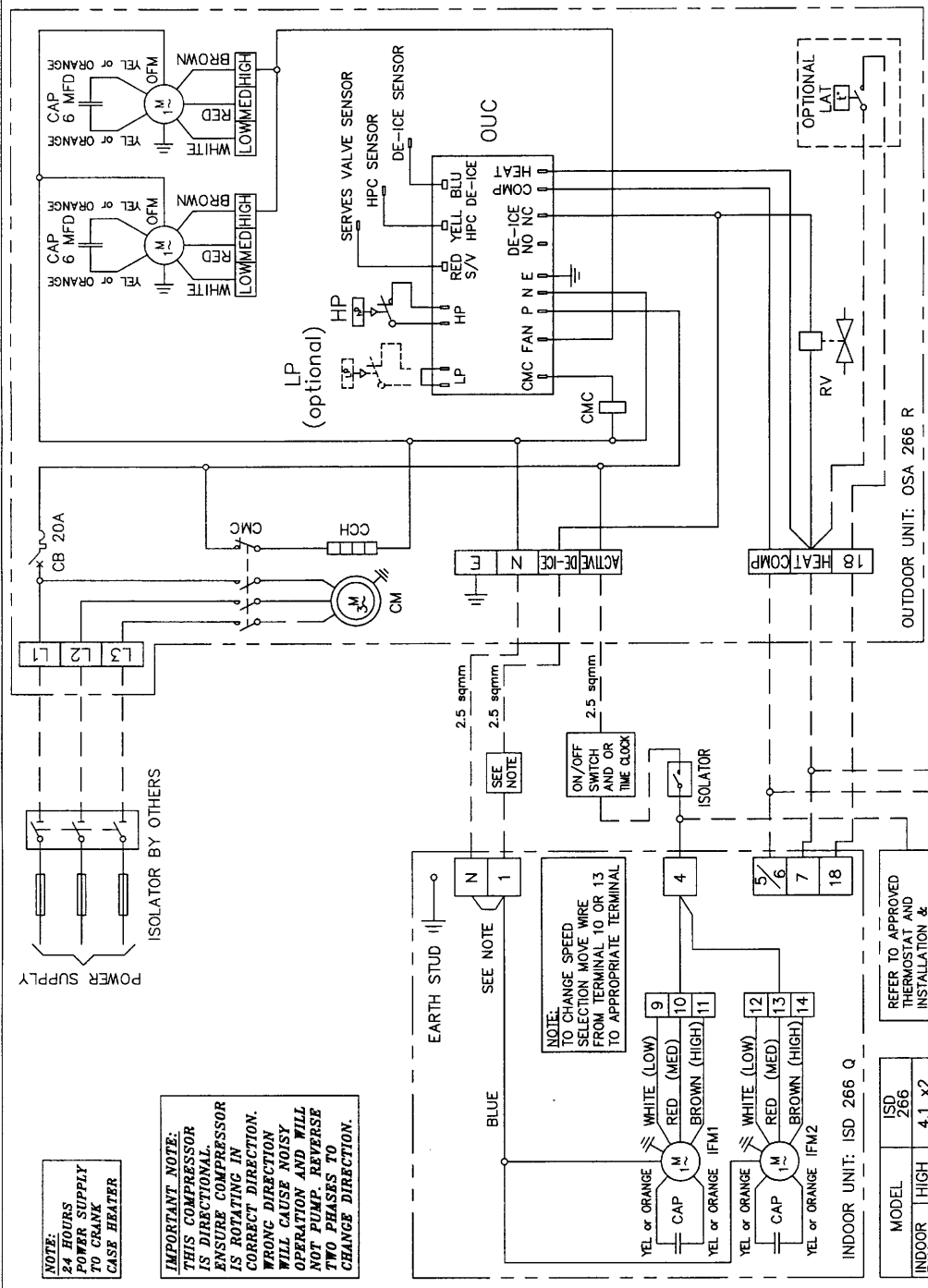

NOTE:  
 24 HOURS  
 POWER SUPPLY  
 TO CRANK  
 CASE HEATER

**IMPORTANT NOTE:**  
 THIS COMPRESSOR IS DIRECTIONAL. ENSURE COMPRESSOR IS ROTATING IN CORRECT DIRECTION. WRONG DIRECTION WILL CAUSE NOISY OPERATION AND WILL NOT PUMP REVERSE TWO PHASES TO CHANGE DIRECTION.

SEE NOTE

NOTE:  
 TO CHANGE SPEED SELECTION MOVE WIRE FROM TERMINAL 10 OR 13 TO APPROPRIATE TERMINAL

REFER TO APPROVED THERMOSTAT AND INSTALLATION & MAINTENANCE DATA SHEETS FOR APPROPRIATE INDOOR UNIT TO BE INSTALLED

MODEL	ISD 266
INDOOR FAN MOTOR RUNNING AMPS	4.1 x2
INDOOR FAN MOTOR CAPACITOR	3.4 x2
INDOOR FAN MOTOR CAPACITOR	1.4 x2
INDOOR FAN MOTOR CAPACITOR	15 x2

**NOTE: FOR REVERSE CYCLE UNITS IT IS RECOMMENDED THE ELECTRICIAN RUN TWO SPARE WIRES BETWEEN OUTDOOR AND INDOOR UNITS. WARNING! DO NOT CONNECT THESE IF OPTIONS BELOW ARE NOT REQUIRED. ONE WIRE IS USED FOR INDOOR FAN OFF IN DE-ICE CYCLE AND LINK BETWEEN TERMINALS (N AND No 1) IN THE INDOOR UNIT MUST BE REMOVED. SECOND WIRE IS FOR OPTIONAL LOW AMBIENT BOOST HEAT AND RUNS FROM INDOOR TERMINAL (No 18) TO OUTDOOR TERMINAL (No 18). A DEDICATED NEUTRAL LINE IS REQUIRED WHERE ELECTRONIC OR ANTICIPATOR T/STATS ARE USED WHEN YOU CHOOSE TO HAVE INDOOR FAN OFF IN DE-ICE.**

PLOTTED  
 02-04-04  
 ©temperzone ltd  
 2004

ISSUE	MODIFICATION	ECN	DATE	APRVD

OUTDOOR UNIT :- OSA 266 R  
WITH INDOOR UNIT

CAPACITIES - NET to AS/AZS 3823	ISD 127 x2	ISD 181 & 85
COOLING -	kW 25.16	26
HEATING - REVERSE CYCLE	kW 27.00	27.3
ELECTRICAL INPUT @ 3PH 400V ~ 50Hz		
COOLING -	kW 9.25	9.55
HEATING - REVERSE CYCLE	kW 7.93	8.2
E.E.R. (COOLING)	kW/kW 2.922	2.88
ELECTRICAL		
SUPPLY REQUIRED 3PH 342-436V ~ 50Hz INCLUDING VOLTAGE FLUCTUATION LIMITS		
COMPRESSOR (3PH) RUN AMPS RATED CONDITIONS A/Ph 14.3	14.6	
INDOOR FAN MOTOR (IPH) FULL LOAD AMPS	A 5 x2 6.3 & 3	
INDOOR FAN MOTOR CAPACITOR	MFD 15 x2 18 & 5	
OUTDOOR FAN MOTOR (IPH) FULL LOAD AMPS	A 0.9 x2	
OUTDOOR FAN MOTOR CAPACITOR	MFD 6 x2	
RUNNING AMPS (TOTAL)	A 25/14/14 25/14/14	
RECOMMENDED EXTERNAL FUSE SIZE	A/Ph 40	40
ELECTRIC HEAT OPTION TOTAL	kW 1x3 x2 1.5x3 & 2	
ELECTRIC HEAT OPTION TOTAL AMPS	A/Ph 4.4 x2 6.6 & 8.8	
RECOMMENDED EXTERNAL FUSE SIZE WITH OPTIONAL ELECTRIC HEAT	A/Ph 50	50
WEIGHT - NETT OSA 266R	208 kg	

REFRIGERANT - HCFC (R22)  
UNIT PRECHARGED (10 METRE LINE LENGTH) 7.5 kg  
BASE CHARGE UNIT 6.9 PLUS 6.9 grams PER METRE LINE LENGTH  
BASED ON LIQUID LINE #13 mm & GAS LINE #28 mm

CAP	CAPACITOR
CB	CIRCUIT BREAKER
CCH	CRANKCASE HEATER
CM	COMPRESSOR MOTOR
CMC	COMPRESSOR CONTACTOR
HP	HI PRESSURE SWITCH
IFM	INDOOR FAN MOTOR
LAT	LOW AMBIENT T/STAT
LP	LOW PRESSURE SWITCH
OFM	OUTDOOR FAN MOTOR
OUC	OUTDOOR UNIT CONTROLLER
RV	REVERSING VALVE

CHECK WIRING BEFORE SWITCHING ON, INCORRECT CONNECTION WILL DAMAGE MOTORS

CLIENT WIRING --- --- ---  
Interconnections between units by client. Double insulated multi-core cable.

**IMPORTANT NOTE:**  
THIS COMPRESSOR IS DIRECTIONAL. ENSURE COMPRESSOR IS ROTATING IN CORRECT DIRECTION. WRONG DIRECTION WILL CAUSE NOISE OPERATION AND WILL NOT PUMP. REVERSE TWO PHASES TO CHANGE DIRECTION.

Consult Outdoor Unit Controller label for further details, or refer to Temperzone for fault diagnosis information.

Sensor Locations:  
Red to service valve pipe pocket.  
Yellow to coil return bend pocket.  
Blue to bottom of coil in fins.

OSA 266 R WITH TWIN INDOOR UNITS  
WIRING SCHEMATIC



temperzone

Drawn P.W-M Date 02-04-04 Drawing No. 426-544-004  
Scale  Revision

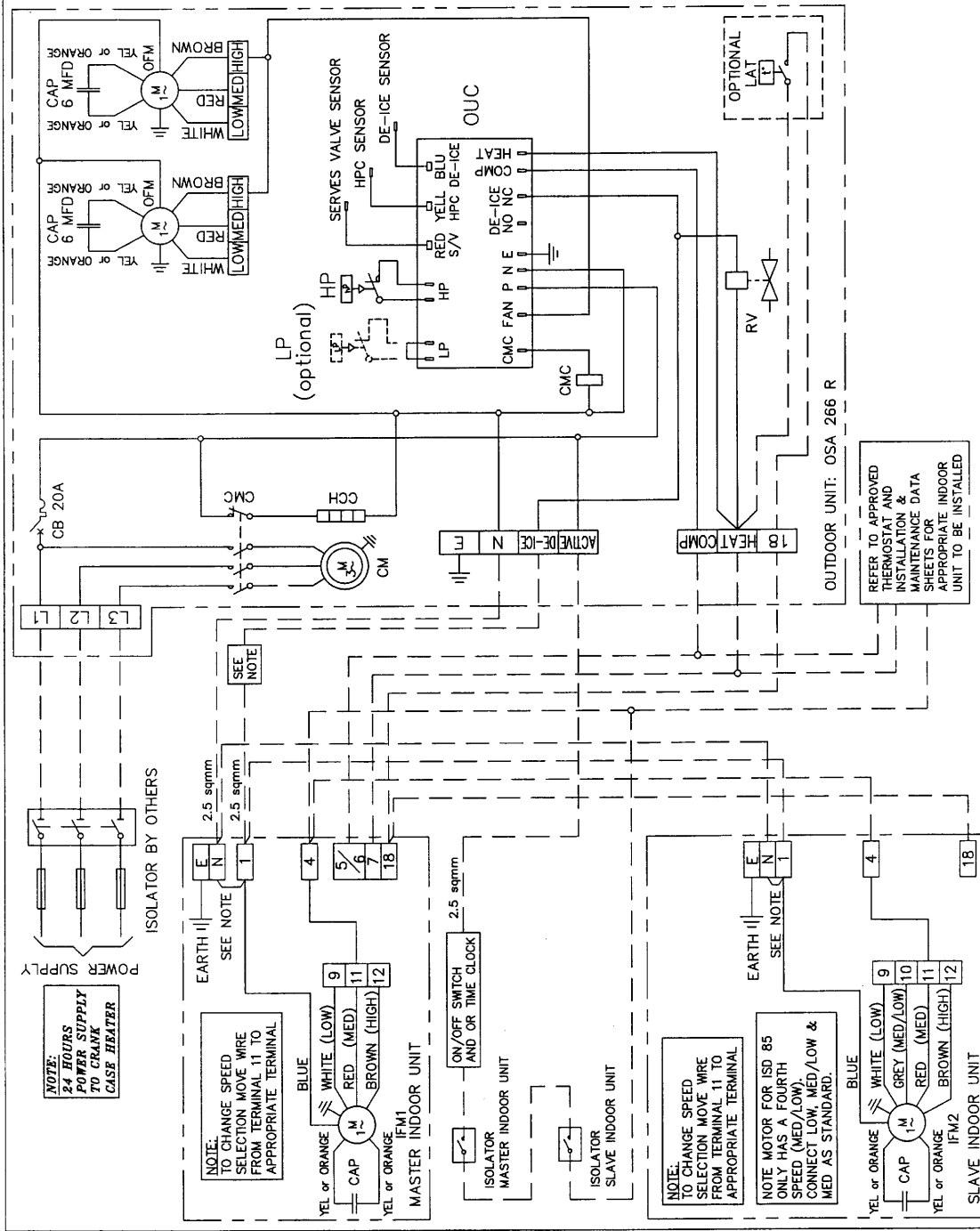

**NOTE: FOR REVERSE CYCLE UNITS IT IS RECOMMENDED THE ELECTRICIAN RUN TWO SPARE WIRES BETWEEN OUTDOOR AND INDOOR UNITS. WARNING: DO NOT CONNECT THESE IF OPTIONS BELOW ARE NOT REQUIRED. ONE WIRE IS USED FOR INDOOR FAN OFF IN DE-ICE CYCLE AND RUNS BETWEEN INDOOR TERMINAL No 11 AND OUTDOOR TERMINAL REMOVED. SECOND WIRE IS FOR OPTIONAL LOW AMBIENT BOOST HEAT AND RUNS FROM INDOOR TERMINAL (No 18) TO OUTDOOR TERMINAL (No 18). A DEDICATED NEUTRAL LINE IS REQUIRED WHERE ELECTRONIC OR ANTICIPATOR T/STATS ARE USED WHEN YOU CHOOSE TO HAVE INDOOR FAN OFF IN DE-ICE.**

MODEL	ISD 127	ISD 181	ISD 85
INDOOR FAN	3.85	5.50	2.60
MOTOR RUNNING AMPS	3.00	4.20	1.70
CAPACITOR MFD	2.40	3.00	1.40
	15	18	5

REFER TO APPROVED THERMOSTAT AND INSTALLATION & MAINTENANCE DATA SHEETS FOR APPROPRIATE INDOOR UNIT TO BE INSTALLED

OUTDOOR UNIT: OSA 266 R

ISSUE MODIFICATION ECN DATE APRVD

PLOTTED  
02-04-04  
©temperzone ltd  
2004