

# OSA 100R

## Single Phase Reverse Cycle Split System Outdoor Unit

## Installation & Maintenance

### GENERAL

This OSA 100R Outdoor Unit must be installed in accordance with all national and local safety codes.

### INSTALLATION

#### Positioning

Refer to dimension diagram below for minimum clearances. Position the unit so that prevailing winds do not blow onto the exhaust to slow the fan, and one unit does not exhaust toward the inlet of another unit.

Mount either free standing or on a wall using the optional mounting brackets available.

#### Free Standing :

Fasten the unit down to a firm flat horizontal base using the four holes provided in the mounting rails.

When the unit is being installed on a roof it is recommended that the unit is installed on a substantial structure with vibration isolating springs beneath the unit. These springs are not supplied with the unit.

#### Wall Mounting Option:

Complete wall mounting instructions are supplied with the optional wall mounting kit.

#### Drain

Install the unit with a positive fall to the rear to ensure condensate and/or rain water drains away freely through the drain holes provided. For a totally drip free installation mount the unit in a separate drain tray.

### REFRIGERATION PIPING

#### General

The OSA 100R is shipped with a refrigerant charge sufficient for a 10 m line length. The matched indoor unit is shipped with a holding charge of nitrogen. OSA 100R units have shut-off service valves, one flare and one brazed pipe connection.

#### Recommended Pipe Sizes

Suction pipe : 19 mm OD  
Liquid pipe : 10 mm OD

### Line Lengths

Maximum extended line length is 40 m. Refer also to *Oil Charge* overleaf.

### Height Separation Limits

Outdoor Unit above Indoor Unit : 12 m  
Outdoor Unit below Indoor Unit : 12 m

### Vertical Risers

If the outdoor unit is to be installed above the indoor unit, then the suction riser should be trapped at the bottom of the vertical rise and then again at 5 m (maximum) intervals. This is to ensure oil return to the compressor. The trap to be a 'swan neck' curve in the pipe, with no change in the pipe size.

### Piping

1. Use clean sealed refrigeration grade piping.
2. Cut pipe with a pipe cutter ONLY.
3. Use long radius bends (2x pipe dia.).
4. Insulate the suction (gas) line and seal all insulation joints.
5. Bi-flow type filter dryer may be fitted in the liquid line.
6. Include a process point in the interconnecting pipework.
7. Ensure open pipe ends are sealed until the final connection is made.
8. **Caution:** To avoid damage to teflon seals, braze suction pipework to stub connection (supplied loose) **before** connecting to unit's valve.
9. Remove valve's dust cap and lubricate teflon seal with refrigeration oil prior to final assembly and connection.

### Charging

The unit is supplied with 2.8 kg of refrigerant HCFC-22 (R22) which is sufficient for up to 10 m of pipework between the indoor and outdoor units. Add 40 g of HCFC-22 per metre above 10 m.

#### Procedure:

1. Evacuate Indoor Unit and interconnecting pipework to a pressure of 500 microns and hold for 15 mins.
2. Add refrigerant, if needed, via the Schraeder connection on the smaller of the Outdoor Unit's two service valves.
3. Open the service valve at the Outdoor Unit to allow refrigerant to flow throughout the system.
4. Leak check all flared joints.

#### IMPORTANT :

Step 8 of the 'Start Up Procedure' requires you to check that the superheat on the suction line (where it enters the Outdoor Unit) is between 3°C – 5°C on cooling cycle with an indoor air temperature in the range

## Dimensions (mm)

## OSA 100R

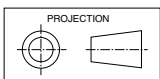

Not to Scale

Net Weight 87 kg

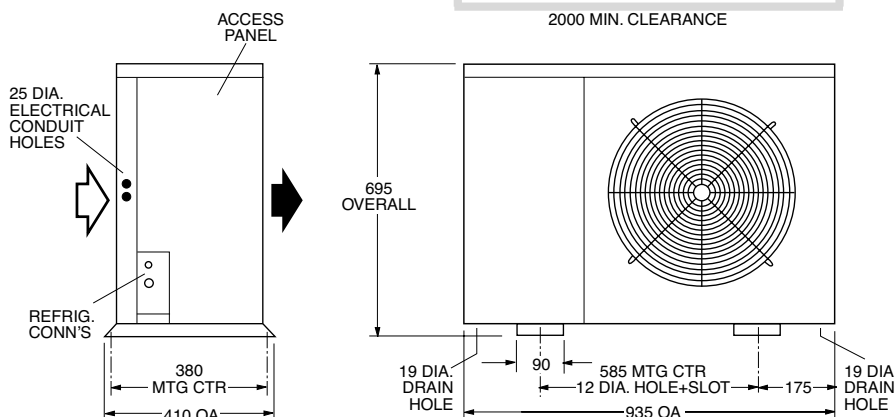
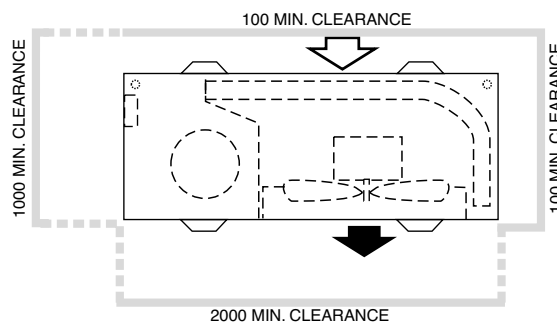

21° – 27°C and outdoor air temperature in the range 24° – 35°C. If the conditions of the day do not allow this, use the heating cycle or other heat source to raise the indoor air temperature to about 24°C. Return to cooling cycle and blank off the outdoor coil to raise the head pressure to 240–280 psig (1750–1950 kPag). Alter charge up or down to establish correct superheat.

**WARNING:**

This unit is designed for use ONLY with the refrigerant HCFC-22. The use of other refrigerants is NOT authorised or approved by the manufacturer and may cause operational problems such as poor performance and efficiency, loss of capacity, degradation of materials and refrigerant leaks. **The use of flammable or explosive materials as a refrigerant creates the additional risks of fire and explosion which may result in property damage, personal injury or death.**

**Oil Charge**

For line lengths in excess of 30 m, Suniso 4GS oil (or similar) should be added to the refrigerant at the rate of 1/2 fluid ounce per metre (13 ml/m) of suction piping.

**ELECTRICAL REQUIREMENTS**

Electrical work must be done by a qualified electrician. The outdoor unit must be wired directly from a distribution board by means of a circuit breaker or H.R.C. fuse, and a mains isolator provided - preferably close to the Outdoor Unit.

**Note:** DO NOT USE REWIRABLE FUSES.

It is recommended electricians run two spare wires between Outdoor Unit and Indoor Unit in case one, or both, of the following options becomes a requirement.

**Note:** Leave the wires unconnected until required.

*Option 1* - Indoor Fan Off During De-Ice (Not required when using **temperzone** TTS-11 Controller).

*Option 2* - Electric Boost Heat.

Refer indoor unit's wiring diagram.

Standard units are suitable for use with thermostats with either manual Heat/Cool selection or automatic changeover subject to the contact ratings of the thermostats. Refer to separate pamphlet for approved thermostats, or contact the manufacturer's nearest sales office.

A 24 hour power supply to the crankcase heaters is required, otherwise the warranty is void.

**SYSTEM CHECK TESTS**

1. Leave the remote switch in the off position and close the mains isolating switch.  
A four hour delay period is required to allow the crankcase heater to drive any liquid refrigerant out of the compressor oil.
2. Check that all fan motors are free running.
3. Check that the thermostat is correctly wired to the unit and is set at the desired temperature.
4. Check that the air filters, if any, have been correctly installed.
5. Check any supply air diffuser dampers are open.

**START UP PROCEDURE**

Use the supplied Commissioning Sheet to help you complete the following procedure:

1. Switch on the unit after the four hour delay period for the crankcase heater has expired.
2. Check the supply voltage.
3. Measure the current draw on the compressor motor and on each fan motor. Check all readings against the specified values - particularly the indoor fan amps if the unit is installed in a free blow application.
4. Fit gauges and measure the suction and discharge pressures.
5. Test the operation of the high pressure safety control by switching off the outdoor unit's fan.
6. Test the operation of the reversing valve by running the unit in both the heating and cooling mode.
7. Check that the air flow over the outdoor unit's coil is adequate and that the fan is running smoothly.
8. Check the superheat - refer charging procedure.
9. Check the supply air flow at each outlet.
10. Touch up any outdoor unit paintwork damage to prevent corrosion.

**OUTDOOR UNIT CONTROLLER (OUC)**

The Outdoor Unit Controller (OUC) includes a temperature sensing head pressure control which enables the system to run efficiently on cooling cycle at outdoor ambient temperatures below 20°C, and heating cycle above 15°C. The OUC also has features which protect against icing or overheating of coils, rapid cycling of the compressor and loss of refrigerant charge.

If the outdoor unit fans take some time to begin rotating when the system is powered on, or they don't appear to be rotating appropriately while the compressor is running, consult the OUC label on the electrical box. If necessary, refer to **temperzone** for further diagnostic information.

**MAINTENANCE**

**Weekly For First Four Weeks**

1. Check indoor unit air filters (if fitted) and vacuum or wash clean as necessary.
2. Check condensate drain for free drainage.
3. Check compressor compartment for oil stains indicating refrigerant leaks.
4. Check tightness of electrical connections.

**Six Monthly**

1. Check the tightness of all fan and motor mountings.
2. Check tightness of electrical connections.
3. Check that fan motors are free running.
4. Check suction and discharge operating pressures.
5. Replace indoor unit air filters (if fitted).
6. Check condensate drain for free drainage.

**Yearly**

1. Check all refrigerant piping for chafing and vibration.
2. Check the operation of electric heaters if fitted.
3. Check air supply at all diffusers.
4. Check for excessive noise and vibration and correct as necessary.
5. Check for insulation and duct damage and repair as necessary.
6. Remove lint and dust accumulation from outdoor coil fins.
7. Touch up any outdoor unit paintwork damage to prevent corrosion.

**NOTE**

The manufacturer reserves the right to change specifications at any time without notice or obligation. Certified dimensions available on request.

This pamphlet replaces the previous issue no. 2312 dated 11/03. OUC added, drain hole dim.

**Pipe Length Capacity Loss  
On Cooling Cycle Due to Pressure Drop**

**Note :** Loss percentages are approximations only, due to piping variations. No allowance made for vertical piping.

Pipe Size (mm)		Equivalent Line Pipe Length (m)					Additional Pipe Length to allow per Bend	
Liquid	Suction	5	10	15	20	30	Suction Pipe Size OD	19 mm
10	19	0.75 %	1.5 %	2.25 %	3 %	5 %	Long 90° Radius (i.e. 2 x pipe dia.)	0.4 m

OUTDOOR UNIT :- OSA 100 R

WITH INDOOR UNIT	ISDL 100	ISD 101	GME 302
CAPACITIES - NET to AS/NZS 3823			
COOLING - kW	9.65	9.50	9.25
HEATING - REVERSE CYCLE kW	10.2	10.2	9.8
ELECTRICAL INPUT			
COOLING - kW	3.6	3.7	3.5
HEATING - REVERSE CYCLE kW	3.1	3.3	3.3
E.E.R. (COOLING) kW/kW	2.731	2.813	2.643

SUPPLY REQUIRED 1PH 200-252V ~ 50Hz INCLUDING VOLTAGE FLUCTUATION LIMITS

COMPRESSOR (1PH) RUN AMPS RATED CONDITIONS	A	15.3	15.5	15.2
COMPRESSOR (1PH) STARTING AMPS	A	45	45	45
COMPRESSOR CAPACITOR RUN	MFD	60	60	60
COMPRESSOR CAPACITOR START	MFD	189/227	189/227	189/227
INDOOR FAN MOTOR (1PH) FULL LOAD AMPS	A	1.4 & 0.7	2.7	1.0
INDOOR FAN MOTOR CAPACITOR	MFD	5	10	3.5
OUTDOOR FAN MOTOR (1PH) FULL LOAD AMPS	A	1.1	1.1	1.1
OUTDOOR FAN MOTOR CAPACITOR	MFD	5	5	5
RUNNING AMPS (TOTAL)		18.5	19	17.8
RECOMMENDED EXTERNAL FUSE SIZE	A	32	32	32
RECOMMENDED EXTERNAL FUSE SIZE WITH OPTIONAL ELECT.HEAT	A	40	40	-

WEIGHT - NETT OSA 100 R 87 kg  
REFRIGERANT - HCFC (R22)  
UNIT PRECHARGED (10 METRE LINE LENGTH) 2.8 kg  
BASE CHARGE UNIT 2.4 kg PLUS 40 grams PER METRE LINE LENGTH  
BASED ON ø10 mm OD LIQUID LINE & ø19 mm OD GAS LINE

Consult Outdoor Unit Controller label for further details, or refer to Temperzone for fault diagnosis information.

Sensor Locations  
Red to service valve pipe pocket.  
Yellow to coil return bend pocket.  
Blue to bottom of coil in fins.

CLIENT WIRING --- --- --- --- ---  
Interconnections between units by client. Double insulated multi-core cable.

CAP	CAPACITOR
CB	CIRCUIT BREAKER
CCH	CRANK CASE HEATER
CM	COMPRESSOR MOTOR
CMC	COMPRESSOR CONTACTOR
HP	HI PRESSURE CONTROL
LP	LOW PRESSURE CONTROL
OFM	OUTDOOR FAN MOTOR
RV	REVERSING VALVE
OUC	OUTDOOR UNIT CONTROLLER
SR	START RELAY

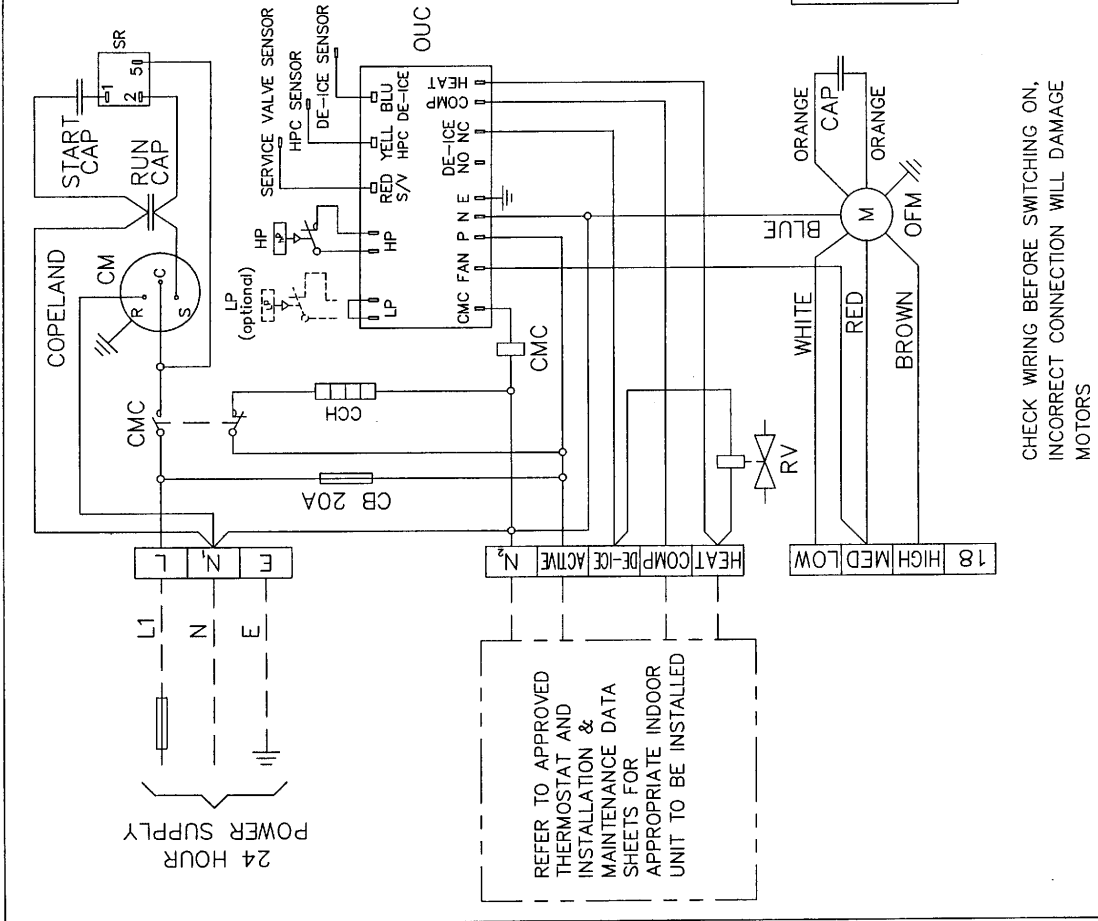

Programmed by

PLOTTED 07-07-04  
©temperzone ltd 2003

Title OSA 100R (O.U.C)  
WIRING SCHEMATIC

Drawn D.W.H Date 25-05-04  
Scale  $\frac{1}{10}$

Revision Drawing No. 426-204-002

ISSUE	MODIFICATION	ECN	DATE	APRVD	DRG SIZE	No.	DESCRIPTION	Mat.l	FINISH No.	ASSY No.



CHECK WIRING BEFORE SWITCHING ON,  
INCORRECT CONNECTION WILL DAMAGE  
MOTORS

