

# OSA 155RKV

## Reverse Cycle R410A Split System Outdoor Unit

## Installation & Maintenance

### GENERAL

**OSA 155RKSV** – single phase version  
**OSA 155RKTV** – three phase version

This OSA 155RKTV Outdoor Unit must be installed in accordance with all national and local safety codes.

### Options

1. Anti-vibration mounts (rubber)
2. Drain connection adaptors - right angle.

### INSTALLATION

#### Positioning

Refer to dimension diagram below for minimum clearances.

Fasten the unit down to a firm flat horizontal base using the four holes provided in the mounting rails. To avoid transfer of vibration, mount the unit on the optional rubber mounts available from **temperzone**.

When the unit is being installed on a roof it is recommended that the unit is installed on a substantial structure with vibration isolating springs or rubber mounts (optional extra) beneath the unit. These items are not supplied with the unit.

### Drain

Four drain holes are provided in the base. Three plastic bungs are supplied (loose) should you want to direct the condensate and/or rain water to one of the holes provided. Drain connection adaptors (25/13) are available as an optional extra.

### REFRIGERATION PIPING

#### General

The OSA 155 is shipped with a refrigerant charge sufficient for a 10 m line length. The matched indoor unit is shipped with a holding charge of nitrogen. OSA 155 units have shut-off service valves and swaged assemblies. Two loose pipe extensions are supplied to enable a choice of exit – side or rear; both require brazing.

#### Recommended Pipe Sizes

Suction pipe : 22 mm OD  
 Liquid pipe : 13 mm OD

### Line Lengths

The standard unit allows for a line length up to 30 m. For line lengths between 30 m and 60 m, refer to **temperzone's Split Systems Installation Guide** (refer [www.temperzone.biz/Technical Support](http://www.temperzone.biz/Technical Support)). Refer also to *Oil Charge* overleaf.

Maximum line length when extended is 60m.

### Height Separation Limits

Outdoor Unit above Indoor Unit : 20 m  
 Outdoor Unit below Indoor Unit : 20 m

### Vertical Risers

If the outdoor unit is to be installed above the indoor unit, then the suction riser should be trapped at the bottom of the vertical rise and then again at 8 m (maximum) intervals. This is to ensure oil return to the compressor. The trap to be a 'swan neck' curve in the pipe, with no change in the pipe size.

### Piping

1. Use clean sealed refrigeration grade piping and accessories designed specifically for R410A.
  2. Cut pipe with a pipe cutter ONLY.
  3. Use long radius bends (2x pipe dia.).
  4. Insulate the suction (gas) line and seal all insulation joints.
  5. Bi-flow type filter dryer may be fitted in the liquid line.
  6. Include a process point in the interconnecting pipework.
  7. Ensure open pipe ends are sealed until the final connection is made.
  8. Immediately before removing brazed pipe connection's seal, reduce holding charge between connection points and service valves to atmospheric pressure.
- Warning:** Failure to do so may cause injury.

### Charging

The unit is supplied with 3.6 kg of refrigerant HFC-410A (R410A) which is sufficient for 10 m of pipework when connected to indoor units ISD 160K. Add, or subtract, 55 g of HFC-410A per metre to suit the installed line length.

#### Procedure:

1. Evacuate Indoor Unit and interconnecting pipework to a pressure of 500 microns and hold for 15 mins.
2. Add refrigerant, if needed, via the Schraeder connection on the smaller of the Outdoor Unit's two service valves.
3. Open the service valve at the Outdoor Unit to allow refrigerant to flow throughout the system.
4. Leak check all brazed and fitted joints.

### Dimensions (mm)

### OSA 155RKV

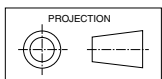

Not to Scale

Net Weight 141 kg

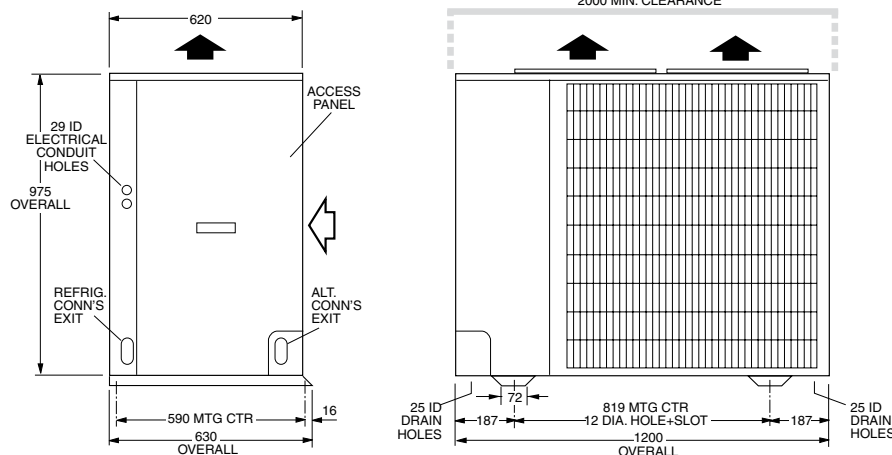
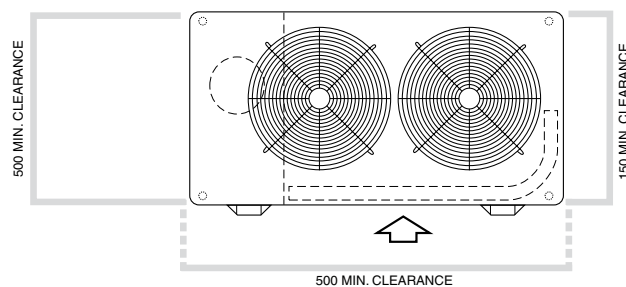

**IMPORTANT :**

Step 8 of the 'Start Up Procedure' requires you to check that the superheat on the suction line (where it enters the Outdoor Unit) is between 3°C – 5°C on cooling cycle with an indoor air temperature in the range 21° – 27°C and outdoor air temperature in the range 24° – 35°C. If the conditions of the day do not allow this, use the heating cycle (on a reverse cycle unit) or other heat source to raise the indoor air temperature to about 24°C and blank off the outdoor coil to raise the head pressure to 400 psig (2760 kPag). Alter charge up or down to establish correct superheat.

**WARNING:**

This unit is designed for use ONLY with the refrigerant HFC-410A. The use of other refrigerants is NOT authorised or approved by the manufacturer and may cause operational problems such as poor performance and efficiency, loss of capacity, degradation of materials and refrigerant leaks. **The use of flammable or explosive materials as a refrigerant creates the additional risks of fire and explosion which may result in property damage, personal injury or death.**

**Oil Charge**

For line lengths in excess of 40 m, Emkarate RL22CF polyolester oil (or similar) should be added to the refrigerant at the rate of 13 ml/m of suction piping. **Note:** Do not use mineral oil.

**ELECTRICAL REQUIREMENTS**

Electrical work must be done by a qualified electrician. The outdoor unit must be wired directly from a distribution board by means of a circuit breaker or H.R.C. fuse, and a mains isolator provided - preferably close to the Outdoor Unit.

**Note:** DO NOT USE REWIRABLE FUSES.

Standard units are suitable for use with thermostats with either manual Heat/Cool selection or automatic changeover subject to the contact ratings of the thermostats.

Refer to **temperzone** for recommended thermostats.

It is recommended electricians run a spare wire between Outdoor Unit and Indoor Unit in case 'Indoor Fan Off During De-Ice' becomes a requirement. Leave this spare wire unconnected until required. (Not required when using **temperzone** SAT-1 Controller). Refer indoor unit's wiring diagram.

A 24 hour power supply is required to the unit. Disconnect the crankcase heater if the total line length is less than 8 m.

**SYSTEM CHECK TESTS**

1. Leave the remote switch in the off position and close the mains isolating switch.  
A four hour delay period is required to allow the crankcase heater to drive any liquid refrigerant out of the compressor oil.
2. Check that all fan motors are free running.
3. *OSA 155RKSV only.* Check for correct rotation of the compressor. If rotation is incorrect the compressor will not pump and will draw minimal current. To correct motor rotation, change the phasing at the main power terminal.
4. Check that the thermostat is correctly wired to the unit and is set at the desired temperature.
5. Check that the air filters, if any, have been correctly installed.
6. Check any supply air diffuser dampers are open.

**START UP PROCEDURE**

Use the supplied Commissioning Sheet to help you complete the following procedure:

1. Switch on the unit after the four hour delay period for the crankcase heater has expired.
2. Check the supply voltage.
3. Measure the current draw on the compressor motor and on each fan motor. Check all readings against the specified values - particularly the indoor fan amps if the unit is installed in a free blow application.
4. Fit gauges and measure the suction and discharge pressures.  
**Important:** Gauges must be designed specifically for use with R410A.
5. Test the operation of the high pressure safety control by switching off the outdoor unit's fan.
6. Test the operation of the reversing valve by running the unit in both the heating and cooling mode.
7. Check that the air flow over the outdoor unit's coil is adequate and that the fan is running smoothly.
8. Check the superheat - refer charging procedure.
9. Check the supply air flow at each outlet.
10. Touch up any outdoor unit paintwork damage to prevent corrosion.

**OUTDOOR UNIT CONTROLLER (OUC)**

The Outdoor Unit Controller (OUC) includes a temperature sensing head pressure control which enables the system to compensate for outdoor ambient temperatures below 20°C, and heating cycle above 15°C. The OUC also has features which protect against icing or overheating of coils, rapid cycling of the compressor and loss of refrigerant charge.

If the outdoor unit fans take some time to begin rotating when the system is powered on, or they don't appear to be rotating appropriately while the compressor is running, consult the OUC label on the electrical box. If necessary, refer to **temperzone** for further diagnostic information.

**MAINTENANCE**

**Weekly For First Four Weeks**

1. Check indoor unit air filters (if fitted) and vacuum or wash clean as necessary.
2. Check condensate drain for free drainage.
3. Check compressor compartment for oil stains indicating refrigerant leaks.
4. Check tightness of electrical connections.

**Six Monthly**

1. Check the tightness of all fan and motor mountings.
2. Check tightness of electrical connections.
3. Check that fan motors are free running.
4. Check suction and discharge operating pressures.
5. Replace indoor unit air filters (if fitted).
6. Check condensate drain for free drainage.

**Yearly**

1. Check all refrigerant piping for chafing and vibration.
2. Check the operation of electric heaters if fitted.
3. Check air supply at all diffusers.
4. Check for excessive noise and vibration and correct as necessary.
5. Check for insulation and duct damage and repair as necessary.
6. Remove lint and dust accumulation from outdoor coil fins.
7. Touch up all outdoor unit paintwork damage to prevent corrosion.

**NOTE**

The manufacturer reserves the right to change specifications at any time without notice or obligation. Certified dimensions available on request.

This pamphlet replaces the previous issue no. 3376 dated 05/10. Change to ball valves.

**Pipe Length Capacity Loss**

**On Cooling Cycle Due to Pressure Drop**

**Note :** Loss percentages are approximations only, due to piping variations. No allowance made for vertical piping.

Pipe Size (mm)		Equivalent Line Pipe Length (m)					Additional Pipe Length to allow per Bend	
Liquid	Suction	5	10	15	20	30	Suction Pipe Size OD	22 mm
13	22	0.7 %	2.1 %	3.4 %	4.7 %	6.1 %	Long 90° Radius (2 x pipe dia.)	0.5 m



OUTDOOR UNIT :- OSA 155RKTV  
 WITH INDOOR UNIT  
 CAPACITIES - NET to AS/NZS 3823  
 COOLING - kW 14.5  
 HEATING - REVERSE CYCLE kW 15.0  
 ELECTRICAL INPUT @ 3PH 400V ~ 50Hz  
 COOLING - kW 4.971  
 HEATING - REVERSE CYCLE kW 4.49  
 E.E.R. (COOLING) kW/kw 2.917  
 ELECTRICAL

SUPPLY REQUIRED 3PH 342-436V ~ 50Hz INCLUDING VOLTAGE FLUCTUATION LIMITS  
 COMPRESSOR (3PH) RUN AMPS RATED CONDITIONS A 7.2 A/Phase  
 INDOOR FAN MOTOR (1PH) FULL LOAD AMPS A 4.4  
 INDOOR FAN MOTOR CAPACITOR MFD 10  
 OUTDOOR FAN MOTOR (1PH) FULL LOAD AMPS A 0.8 x2  
 OUTDOOR FAN MOTOR CAPACITOR MFD 5 & 6  
 RUNNING AMPS (TOTAL) A 11.2/7.7/7.2  
 RECOMMENDED EXTERNAL FUSE SIZE A 25  
 WEIGHT - NETT OSA 155RKTV 141Kg  
 REFRIGERANT - R410A  
 UNIT REFRIGERANT PRECHARGE (10 METRE LINE LENGTH) 3.6 Kg  
 BASE REFRIGERANT CHARGE UNIT 3.0 Kg PLUS 60 grams PER METRE LINE LENGTH  
 BASED ON ø12.7 OD LIQUID LINE & ø22 OD GAS LINE

COMPRESSOR TYPE : SCROLL  
 OIL TYPE : POLYOLESTER (P.O.E.)  
 ADD ADDITIONAL OIL 13 ml PER METRE OVER 40 METRE LINE LENGTH  
 Consult Outdoor Unit Controller label for further details or refer to temperzone for fault diagnosis information.  
 Sensor Locations:  
 Red to service valve pipe pocket.  
 Yellow to coil return bend pocket.  
 Blue to bottom of coil in fins.

ABB	DESCRIPTION
CAP	CAPACITOR
CB	CIRCUIT BREAKER
CCH	CRANK CASE HEATER
CM	COMPRESSOR MOTOR
CMC	COMPRESSOR CONTACTOR
HP	HI PRESSURE CONTROL
LP	LOW PRESSURE CONTROL
OUC	OUTDOOR UNIT CONTROLLER
OFM	OUTDOOR FAN MOTOR
RV	REVERSING VALVE

CHECK WIRING BEFORE SWITCHING ON,  
 INCORRECT CONNECTION WILL DAMAGE  
 MOTORS  
 CLIENT WIRING \_\_\_\_\_  
 interconnections between units by  
 client. Double insulated multi-core  
 cable.

Programmed by	Title
PLOTTED 16-11-09 ©temperzone ltd 2003	OSA 155RKTV WIRING SCHEMATIC
Drawn D.A.B	Date 29-06-05
Scale	526-314-002
Revision	E

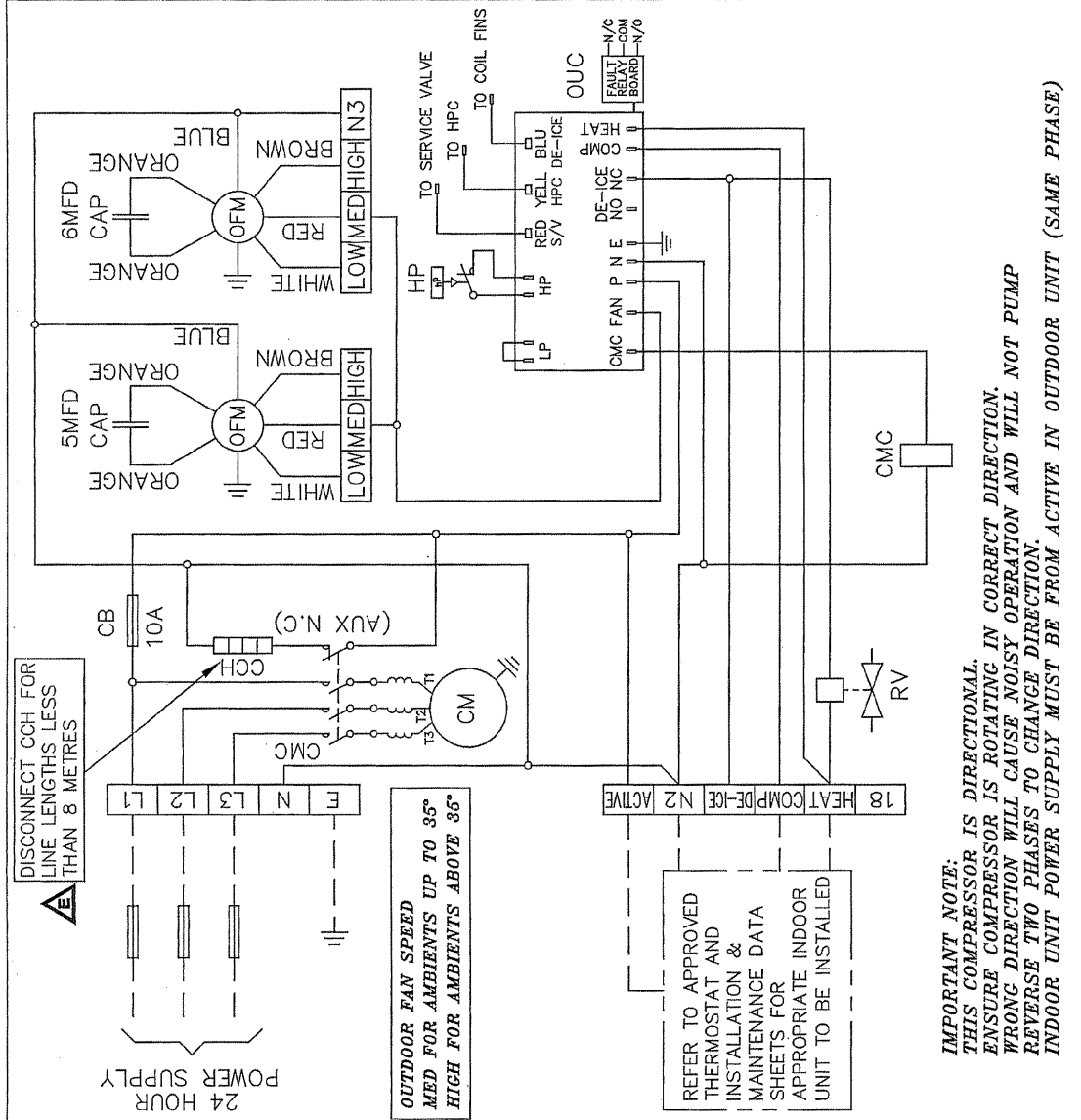

ISSUE	MODIFICATION	ECN	DATE	APRVD	DRG SIZE	No.	DESCRIPTION	Mat'l	FINISH	ASSY No.
E	DISCONNECT CCH NOTE ADDED	N2343	16-11-09	ROD						
D	40 METRES WAS 10 METRES	N2228	09-06-09	ROD						
C	WIRING CORRECTED. 4.4/7.0 WERE 3.12/7.2. FAULT RELAY BOARD FITTED. CM DETAIL UPDATED. LP OPTION REMOVED	N221	15-06-09	D.A.B.						
B	WEIGHT NOW 141Kg, WAS 136Kg	N780	18-02-08	D.A.B.						
A	CAPACITORS CHANGED TO 5 & 6 MFD	N1702	20-12-07	SDH						

DO NOT PUMP DOWN SYSTEM WITH THIS COMPRESSOR

