

OSA 465RKTBV (c/w UC6 Controller)

Reverse Cycle R410A Split System Outdoor Unit

Installation & Maintenance

GENERAL

The OSA 465RKTBV outdoor unit is a twin system that provides the facility for capacity control (staging) or staggered starting.

This OSA 465RKTBV Outdoor Unit must be installed in accordance with all national and local safety codes.

Options

1. TZX-100 Room Temperature Controller
2. UC6 Service Interface tool.

INSTALLATION

Positioning

Refer to dimension diagram below for minimum clearances. Fasten the unit down to a firm flat horizontal base using the six holes provided in the mounting rails.

When the unit is being installed on a roof it is recommended that the unit is installed on a substantial structure with vibration isolating springs. These springs are not supplied with the unit.

Drain

Four drain holes are provided in the base of the unit to release condensate and/or rain water.

REFRIGERATION PIPING

General

The OSA 465 is shipped with a refrigerant charge sufficient for a 10 m line length. The matched indoor unit is shipped with a holding charge of nitrogen. OSA 465 units have brazed pipe connections.

Recommended Pipe Sizes

Suction pipe (x2): 22 mm OD
Liquid pipe (x2): 13 mm OD

Line Lengths

The standard unit is suitable for a line length up to 40 m. For line lengths between 40 m and 60 m, refer to **temperzone's Split Systems Installation Guide** (refer www.temperzone.biz/Technical Support). Refer also to *Oil Charge* overleaf.

Maximum line length when extended is 60m.

Height Separation Limits

Outdoor Unit above Indoor Unit : 20 m
Outdoor Unit below Indoor Unit : 20 m

Vertical Risers

If the outdoor unit is to be installed above the indoor unit, then the suction riser should be trapped at the bottom of the vertical rise and then again at 8 m (maximum) intervals. This is to ensure oil return to the compressor. The trap to be a 'swan neck' curve in the pipe, with no change in the pipe size.

Piping

1. Use clean sealed refrigeration grade piping and accessories designed specifically for R410A.
 2. Cut pipe with a pipe cutter ONLY.
 3. Use long radius bends (2x pipe dia.).
 4. Insulate the suction (gas) line and seal all insulation joints.
 5. Bi-flow type filter dryer may be fitted in the liquid line.
 6. Include a process port on the interconnecting pipework.
 7. Ensure open pipe ends are sealed until the final connection is made.
 8. Immediately before removing brazed pipe connection's seal, reduce holding charge between connection points and service valves to atmospheric pressure.
- Warning:** Failure to do so may cause injury.

Important

Do not connect System 1 to System 2.

Charging

The unit is supplied with sufficient refrigerant HFC-410A (R410A) for 10 m of pipework between the indoor and outdoor units; refer wiring diagram specification table for amount. Add 100 g per metre per system above 10 m.

Procedure (per system):

1. Evacuate Indoor Unit and interconnecting pipework to a pressure of 500 microns and hold for 15 mins.
2. Add refrigerant via the Schraeder connection on the smaller of the Outdoor Unit's two service valve extension pipes.
3. Open the service valve at the Outdoor Unit to allow refrigerant to flow throughout the system.
4. Leak check all brazed and fitted joints.

IMPORTANT :

Step 8 of the 'Start Up Procedure' requires you to check that the superheat on the suction line (where it enters the Outdoor Unit) is between 3°C – 5°C on cooling cycle with an indoor air temperature in the range 21° – 27°C and outdoor air temperature in

Dimensions (mm)

OSA 465RKTBV

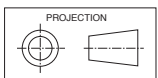

Not to Scale

Net Weight 445 kg

| CORNER LOADS (kg) | | | |
|-------------------|----|----|-----|
| W | X | Y | Z |
| 146 | 77 | 77 | 145 |

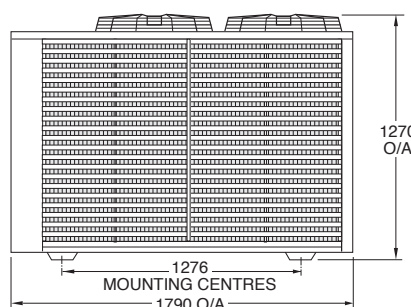
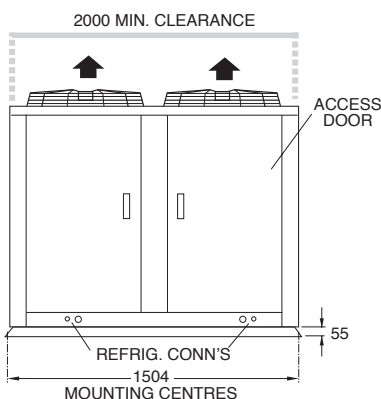
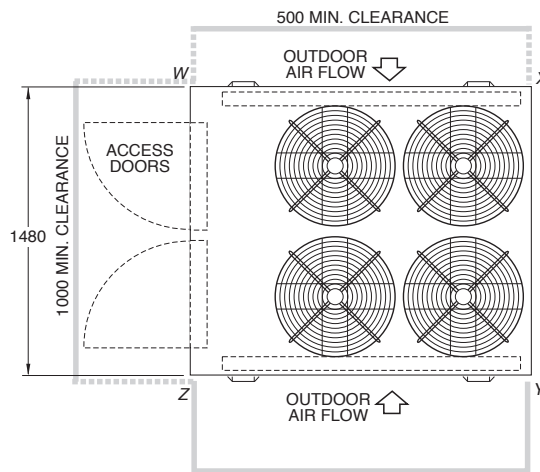

the range 24° – 35°C. If the conditions of the day do not allow this, use the heating cycle (on a reverse cycle unit) or other heat source to raise the indoor air temperature to about 24°C and blank off the outdoor coil to raise the head pressure to 400 psig (2760 kPag). Alter charge up or down to establish correct superheat.

WARNING:

This unit is designed for use ONLY with the refrigerant HFC-410A (R410A). The use of other refrigerants is NOT authorised or approved by the manufacturer and may cause operational problems such as poor performance and efficiency, loss of capacity, degradation of materials and refrigerant leaks. **The use of flammable or explosive materials as a refrigerant creates the additional risks of fire and explosion which may result in property damage, personal injury or death.**

Oil Charge

For line lengths in excess of 30 m, Emkarate RL22CF polyolester oil (or similar) should be added to the refrigerant at the rate of 30 ml/m of suction piping.

Note: This oil absorbs moisture quickly if exposed to open air. Do not use mineral oil.

ELECTRICAL REQUIREMENTS

Electrical work must be done by a qualified electrician. The outdoor unit must be wired directly from a distribution board by means of a circuit breaker or H.R.C. fuse, and a mains isolator provided - preferably close to the Outdoor Unit.

Note: DO NOT USE REWIRABLE FUSES.

The OSA 465 is provided with a 24V AC control circuit for a thermostat, on/off switch and/or time clock.

The control transformer 240V primary voltage is used for countries with 230-240V power supply. For countries with supply voltages 200-220V, change the primary voltage on the transformer to 208V.

Standard units are suitable for use with thermostats with either manual Heat/Cool selection or automatic changeover subject to the contact ratings of the thermostats.

Refer to **temperzone** for recommended thermostats.

A 24 hour power supply to the crankcase heaters is required, otherwise the warranty is void.

SYSTEM CHECK TESTS

1. Check by hand that all fan motors can turn freely.
2. Check the tightness of all electrical connections and sign the check label.
3. Leave the room temp. thermostat in the off position and close the mains isolating switch. (A four hour delay period is required to allow the crankcase heater to drive any liquid refrigerant out of the compressor oil.)
4. Check the supply voltage between each phase and neutral.

5. Check that the thermostat is correctly wired to the unit and is set at the desired temperature.
6. Check that the air filters, if any, have been correctly installed.
7. Check any supply air diffuser dampers are open.

START UP PROCEDURE

Check each system independently first before running complete system. After the four hour delay for the crankcase heater has expired, use the supplied Commissioning Sheet (Form NS 217) to record results when completing the following 'Start-up' procedure. Ideally a *UC6 Service Interface* and associated communication cable (temperzone part no.s 201-000-379 and 201-000-378) should be used to read, pressures, superheat and its set-point, compressor amps etc.

1. Select a sensible Fan speed (or Auto Fan mode), operating cycle (cool or heat), and room temperature set point, depending on the time of year, such that the compressor will start and run at a high capacity.
2. Turn ON the thermostat / External controller. Wait for the compressor to start and reach a stable speed. Measure the current for each phase feeding into the compressor's. Compare against the compressor amps specified on the unit's wiring diagram.
3. Check for correct rotation of the compressor. If rotation is incorrect the compressor will not pump and will draw minimal current. To correct motor rotation, change the phasing at the main power terminal.
4. Measure the current draw of each fan motor. Check all readings against the specified values in the wiring diagram.
5. If a *UC6 Service Interface* is available, operating pressures and status can be read from its various display screens. If a *UC6 Service Interface* is not available, fit gauges and measure the suction and discharge pressures of both refrigeration circuits.
Important: Gauges must be designed specifically for use with R410A.
6. Check that the outdoor air fan motors are running smoothly and drawing less than the full load amps specified.
7. Check the superheat - refer charging procedure.
8. Check the indoor unit's fan belt tension after 20 mins of operation and adjust if necessary (refer Commissioning Sheet).
7. Test the operation of the reversing valve by running the unit in both the heating and cooling mode.
8. Check the supply air flow at each outlet.
9. Touch up any outdoor unit paintwork damage to prevent corrosion.

SETTING SUPPLY AIR FLOW

Consult ISD/OSA 465 Technical Data pamphlet at www.temperzone.biz for details of airflow/duct static pressure, if required.

If the indoor air returning to the unit is regularly expected to be above 50%RH, then the coil face velocity should be limited to be 2.5 m/s or less (refer Air Handling graph in Technical Data pamphlet) to avoid water carry-over problems.

UNIT CONTROLLER (UC6)

The Unit Controller provides system protection functions such as coil frost protection, de-icing, high head pressure and low suction pressure cut-out. It also protects against rapid cycling of the compressor and loss of refrigerant. The UC regulates the superheat of the refrigeration system by controlling the position of an Electronic Expansion Valve (EEV). Various methods of head pressure control (or limiting) are employed in temperzone units. The particular method used varies from model to model, but is handled by the Unit Controller. In combination, these features deliver optimised performance across a wide operating temperature range.

Refer to UC6 Controller label on the unit for operation & fault diagnostics information. Many operating status conditions can be determined, without gauges, simply by using a *UC6 Service Interface* graphical display available from **temperzone**.

MAINTENANCE

Weekly For First Four Weeks

1. Check air filters, if fitted, and vacuum or wash clean as necessary.
2. Check condensate drain for free drainage.
3. Check compressor compartment for oil stains indicating refrigerant leaks.

Three Monthly (or every 1200 hrs of operation)

Check the indoor unit's fan belt tension and adjust if necessary.

Six Monthly

1. Check the tightness of electrical connections.
2. Check the tightness of fans and motor mountings.
3. Check suction and discharge operating pressures. (Using a *UC6 Service Interface* avoids fitting and removing gauges with consequential refrigerant loss.)
4. Replace indoor unit air filters (if fitted).
5. Check condensate drain for free drainage.

Yearly

1. Check all refrigerant piping for chafing and vibration.
2. Check air supply at all diffusers.
3. Check for excessive noise and vibration and correct as necessary.
4. Check for insulation and duct damage and repair as necessary.
5. Check and remove as necessary any lint and dust accumulation from outdoor coil fins. In corrosive environments, the checking and cleaning frequency should be increased.
6. Touch up all outdoor unit paintwork damage to prevent corrosion.

Pipe Length Capacity Loss

On Cooling Cycle Due to Pressure Drop

Note : Loss percentages are approximations only, due to piping variations. No allowance made for vertical piping.

| Performance Loss per additional 10m beyond first 5m. | Suction Pipe Size OD | Additional Pipe Length to allow per Bend Long 90° Radius (2 x pipe dia.) |
|--|----------------------|--|
| 2.1 % | 22 mm | 0.5 m |

| 0 | 1 | 2 | 3 | 4 | 5 | 6 | 7 | 8 | 9 | | | | | | | | | | | | | | | | | | | | | | | | | | | | | | | | | | | | | | | | | | | | | | | | | | | | | | | | | | | | | | | | | | | | | | | | | | | | | | | | | | | | | | | | | | | | | |
|--|---|-------------------|----------|----------|---|---|---|---|---|-----------|-------------|--------|-------------------------|----------------|-------|--------------------|----------------|----------|-----------|------------------|---------------|-------------------------|------------------|--------|------------------|------------------------------|-------------------|--------------------|-----------------|------|---|---------------------------|--------------|--------|---|---------------|------|-----------------------------|---------------|------|------------------------------|---------|-------|---------------------|-------|-----|------------------------|----|--|---------------------------------------|-----|------|----------------------------------|---|--|------------------------------------|-----|------|---------------------------|---|--|----------------------------|-----|------|--|-----|--|-----------------------------------|---|--|----------------------|---------|--|------------------|----|-------|-------------------------------------|------|-----|-------------------------|----------|-------|-------------------------|------|--|-------------|---|--|--|---|--|--|---|--|--|---|--|--|----|--|--|-----|
| <p>Important Notes:</p> <p>1) Crankcase Heater Note 24 Hour power required (on L1) SW1 SW2 SW3 SW4 Off Off Off Off heaters</p> <p>2) Damper Terminal Note Y - 0-10 Volt DC GO - Common G - 24 Volt HOT</p> <p>3) Important Note Compressors fitted are directional. If rotation incorrect, compressor/s will not pump, be noisy, and draw minimal current. To correct rotation, reverse two phases.</p> <p>UC6: Sensors (S) / Transducers (T)</p> <table border="1"> <thead> <tr> <th>Name</th> <th>Type</th> <th>Colour</th> </tr> </thead> <tbody> <tr> <td>ST1</td> <td>Suction Temp 1</td> <td>WHITE</td> </tr> <tr> <td>ST2</td> <td>Suction Temp 2</td> <td>WHITE</td> </tr> <tr> <td>DT1</td> <td>Discharge Temp 1</td> <td>GREY</td> </tr> <tr> <td>DT2</td> <td>Discharge Temp 2</td> <td>GREY</td> </tr> <tr> <td>SP1</td> <td>Suction Press 1</td> <td rowspan="3">3 Core Grey Cable</td> </tr> <tr> <td>SP2</td> <td>Suction Press 2</td> </tr> <tr> <td>HP1</td> <td>High Press 1</td> </tr> <tr> <td>HP2</td> <td>High Press 2</td> <td>BLUE</td> </tr> <tr> <td>TS1</td> <td>De-ice Temp 1</td> <td>BLUE</td> </tr> <tr> <td>TS2</td> <td>De-ice Temp 2</td> <td>BLUE</td> </tr> <tr> <td>OAT</td> <td>Ambient</td> <td>BLACK</td> </tr> </tbody> </table> | | | | | | | | | | Name | Type | Colour | ST1 | Suction Temp 1 | WHITE | ST2 | Suction Temp 2 | WHITE | DT1 | Discharge Temp 1 | GREY | DT2 | Discharge Temp 2 | GREY | SP1 | Suction Press 1 | 3 Core Grey Cable | SP2 | Suction Press 2 | HP1 | High Press 1 | HP2 | High Press 2 | BLUE | TS1 | De-ice Temp 1 | BLUE | TS2 | De-ice Temp 2 | BLUE | OAT | Ambient | BLACK | | | | | | | | | | | | | | | | | | | | | | | | | | | | | | | | | | | | | | | | | | | | | | | | | | | | | | | | | | | |
| Name | Type | Colour | | | | | | | | | | | | | | | | | | | | | | | | | | | | | | | | | | | | | | | | | | | | | | | | | | | | | | | | | | | | | | | | | | | | | | | | | | | | | | | | | | | | | | | | | | | | | | | | | | | | |
| ST1 | Suction Temp 1 | WHITE | | | | | | | | | | | | | | | | | | | | | | | | | | | | | | | | | | | | | | | | | | | | | | | | | | | | | | | | | | | | | | | | | | | | | | | | | | | | | | | | | | | | | | | | | | | | | | | | | | | | |
| ST2 | Suction Temp 2 | WHITE | | | | | | | | | | | | | | | | | | | | | | | | | | | | | | | | | | | | | | | | | | | | | | | | | | | | | | | | | | | | | | | | | | | | | | | | | | | | | | | | | | | | | | | | | | | | | | | | | | | | |
| DT1 | Discharge Temp 1 | GREY | | | | | | | | | | | | | | | | | | | | | | | | | | | | | | | | | | | | | | | | | | | | | | | | | | | | | | | | | | | | | | | | | | | | | | | | | | | | | | | | | | | | | | | | | | | | | | | | | | | | |
| DT2 | Discharge Temp 2 | GREY | | | | | | | | | | | | | | | | | | | | | | | | | | | | | | | | | | | | | | | | | | | | | | | | | | | | | | | | | | | | | | | | | | | | | | | | | | | | | | | | | | | | | | | | | | | | | | | | | | | | |
| SP1 | Suction Press 1 | 3 Core Grey Cable | | | | | | | | | | | | | | | | | | | | | | | | | | | | | | | | | | | | | | | | | | | | | | | | | | | | | | | | | | | | | | | | | | | | | | | | | | | | | | | | | | | | | | | | | | | | | | | | | | | | |
| SP2 | Suction Press 2 | | | | | | | | | | | | | | | | | | | | | | | | | | | | | | | | | | | | | | | | | | | | | | | | | | | | | | | | | | | | | | | | | | | | | | | | | | | | | | | | | | | | | | | | | | | | | | | | | | | | | |
| HP1 | High Press 1 | | | | | | | | | | | | | | | | | | | | | | | | | | | | | | | | | | | | | | | | | | | | | | | | | | | | | | | | | | | | | | | | | | | | | | | | | | | | | | | | | | | | | | | | | | | | | | | | | | | | | |
| HP2 | High Press 2 | BLUE | | | | | | | | | | | | | | | | | | | | | | | | | | | | | | | | | | | | | | | | | | | | | | | | | | | | | | | | | | | | | | | | | | | | | | | | | | | | | | | | | | | | | | | | | | | | | | | | | | | | |
| TS1 | De-ice Temp 1 | BLUE | | | | | | | | | | | | | | | | | | | | | | | | | | | | | | | | | | | | | | | | | | | | | | | | | | | | | | | | | | | | | | | | | | | | | | | | | | | | | | | | | | | | | | | | | | | | | | | | | | | | |
| TS2 | De-ice Temp 2 | BLUE | | | | | | | | | | | | | | | | | | | | | | | | | | | | | | | | | | | | | | | | | | | | | | | | | | | | | | | | | | | | | | | | | | | | | | | | | | | | | | | | | | | | | | | | | | | | | | | | | | | | |
| OAT | Ambient | BLACK | | | | | | | | | | | | | | | | | | | | | | | | | | | | | | | | | | | | | | | | | | | | | | | | | | | | | | | | | | | | | | | | | | | | | | | | | | | | | | | | | | | | | | | | | | | | | | | | | | | | |
| A | <p>Capacities - Nett to AS/NZS 3823</p> <table border="1"> <tr> <td>Cooling -</td> <td>OSA</td> <td>465KB</td> </tr> <tr> <td>Heating - Reverse Cycle</td> <td>KW</td> <td>42.64</td> </tr> <tr> <td>Electrical Input</td> <td>KW</td> <td>43.97</td> </tr> <tr> <td>Cooling -</td> <td>KW</td> <td>14.32</td> </tr> <tr> <td>Heating - Reverse Cycle</td> <td>KW</td> <td>12.46</td> </tr> <tr> <td>E.E.R. (Cooling)</td> <td>KW/KW</td> <td>2.98</td> </tr> <tr> <td>A.E.E.R. (Cooling)</td> <td>KW/KW</td> <td>2.95</td> </tr> </table> <p>Supply required 3Ph 380-415V ~ 50Hz</p> <table border="1"> <tr> <td>CM</td> <td>Compressors type : Scroll</td> <td>Z983 X2</td> </tr> <tr> <td></td> <td>Compressor (3Ph) Full Load Amps rating conditions</td> <td>11 X2</td> </tr> <tr> <td>CMCB</td> <td>Compressor Circuit Breakers</td> <td>A/Ph</td> </tr> <tr> <td>CMOL</td> <td>Compressor Overload settings</td> <td>A</td> </tr> <tr> <td></td> <td>Compressor Oil Type</td> <td>P.O.E</td> </tr> <tr> <td>IFM</td> <td>Indoor Fan Motor (3Ph)</td> <td>KW</td> </tr> <tr> <td></td> <td>Indoor Fan Motor (3Ph) Full Load Amps</td> <td>3.0</td> </tr> <tr> <td>IFCB</td> <td>Indoor Fan Motor Circuit Breaker</td> <td>A</td> </tr> <tr> <td></td> <td>Indoor Fan Motor Overload settings</td> <td>6.2</td> </tr> <tr> <td>IFOL</td> <td>Indoor Fan Motor Overload</td> <td>A</td> </tr> <tr> <td></td> <td>Indoor Fan Motor Capacitor</td> <td>6.5</td> </tr> <tr> <td>OFCB</td> <td>Outdoor Fan Motor (1Ph) Full Load Amps</td> <td>MFD</td> </tr> <tr> <td></td> <td>Outdoor Fan Motor Circuit Breaker</td> <td>A</td> </tr> <tr> <td></td> <td>Running Amps (total)</td> <td>1.7 X 4</td> </tr> <tr> <td></td> <td>Max Running Amps</td> <td>16</td> </tr> <tr> <td>SPSCB</td> <td>Single Phase Socket Circuit Breaker</td> <td>A/Ph</td> </tr> <tr> <td>CCB</td> <td>Control Circuit Breaker</td> <td>31/25/75</td> </tr> <tr> <td>24VCB</td> <td>24 Volt Circuit Breaker</td> <td>A/Ph</td> </tr> <tr> <td></td> <td>Weight-Nett</td> <td>A</td> </tr> <tr> <td></td> <td></td> <td>2</td> </tr> <tr> <td></td> <td></td> <td>A</td> </tr> <tr> <td></td> <td></td> <td>2</td> </tr> <tr> <td></td> <td></td> <td>Kg</td> </tr> <tr> <td></td> <td></td> <td>445</td> </tr> </table> <p>Unit precharged (10m line length) 7.6Kg per system (R410A refrigerant) Base charge 6.6Kg plus 100grams per metre line length per system (Based on 12.7 dia liquid line & 22.23 dia gas line) Add additional oil (20ml per metre over 40 metre line length)</p> | | | | | | | | | Cooling - | OSA | 465KB | Heating - Reverse Cycle | KW | 42.64 | Electrical Input | KW | 43.97 | Cooling - | KW | 14.32 | Heating - Reverse Cycle | KW | 12.46 | E.E.R. (Cooling) | KW/KW | 2.98 | A.E.E.R. (Cooling) | KW/KW | 2.95 | CM | Compressors type : Scroll | Z983 X2 | | Compressor (3Ph) Full Load Amps rating conditions | 11 X2 | CMCB | Compressor Circuit Breakers | A/Ph | CMOL | Compressor Overload settings | A | | Compressor Oil Type | P.O.E | IFM | Indoor Fan Motor (3Ph) | KW | | Indoor Fan Motor (3Ph) Full Load Amps | 3.0 | IFCB | Indoor Fan Motor Circuit Breaker | A | | Indoor Fan Motor Overload settings | 6.2 | IFOL | Indoor Fan Motor Overload | A | | Indoor Fan Motor Capacitor | 6.5 | OFCB | Outdoor Fan Motor (1Ph) Full Load Amps | MFD | | Outdoor Fan Motor Circuit Breaker | A | | Running Amps (total) | 1.7 X 4 | | Max Running Amps | 16 | SPSCB | Single Phase Socket Circuit Breaker | A/Ph | CCB | Control Circuit Breaker | 31/25/75 | 24VCB | 24 Volt Circuit Breaker | A/Ph | | Weight-Nett | A | | | 2 | | | A | | | 2 | | | Kg | | | 445 |
| Cooling - | OSA | 465KB | | | | | | | | | | | | | | | | | | | | | | | | | | | | | | | | | | | | | | | | | | | | | | | | | | | | | | | | | | | | | | | | | | | | | | | | | | | | | | | | | | | | | | | | | | | | | | | | | | | | |
| Heating - Reverse Cycle | KW | 42.64 | | | | | | | | | | | | | | | | | | | | | | | | | | | | | | | | | | | | | | | | | | | | | | | | | | | | | | | | | | | | | | | | | | | | | | | | | | | | | | | | | | | | | | | | | | | | | | | | | | | | |
| Electrical Input | KW | 43.97 | | | | | | | | | | | | | | | | | | | | | | | | | | | | | | | | | | | | | | | | | | | | | | | | | | | | | | | | | | | | | | | | | | | | | | | | | | | | | | | | | | | | | | | | | | | | | | | | | | | | |
| Cooling - | KW | 14.32 | | | | | | | | | | | | | | | | | | | | | | | | | | | | | | | | | | | | | | | | | | | | | | | | | | | | | | | | | | | | | | | | | | | | | | | | | | | | | | | | | | | | | | | | | | | | | | | | | | | | |
| Heating - Reverse Cycle | KW | 12.46 | | | | | | | | | | | | | | | | | | | | | | | | | | | | | | | | | | | | | | | | | | | | | | | | | | | | | | | | | | | | | | | | | | | | | | | | | | | | | | | | | | | | | | | | | | | | | | | | | | | | |
| E.E.R. (Cooling) | KW/KW | 2.98 | | | | | | | | | | | | | | | | | | | | | | | | | | | | | | | | | | | | | | | | | | | | | | | | | | | | | | | | | | | | | | | | | | | | | | | | | | | | | | | | | | | | | | | | | | | | | | | | | | | | |
| A.E.E.R. (Cooling) | KW/KW | 2.95 | | | | | | | | | | | | | | | | | | | | | | | | | | | | | | | | | | | | | | | | | | | | | | | | | | | | | | | | | | | | | | | | | | | | | | | | | | | | | | | | | | | | | | | | | | | | | | | | | | | | |
| CM | Compressors type : Scroll | Z983 X2 | | | | | | | | | | | | | | | | | | | | | | | | | | | | | | | | | | | | | | | | | | | | | | | | | | | | | | | | | | | | | | | | | | | | | | | | | | | | | | | | | | | | | | | | | | | | | | | | | | | | |
| | Compressor (3Ph) Full Load Amps rating conditions | 11 X2 | | | | | | | | | | | | | | | | | | | | | | | | | | | | | | | | | | | | | | | | | | | | | | | | | | | | | | | | | | | | | | | | | | | | | | | | | | | | | | | | | | | | | | | | | | | | | | | | | | | | |
| CMCB | Compressor Circuit Breakers | A/Ph | | | | | | | | | | | | | | | | | | | | | | | | | | | | | | | | | | | | | | | | | | | | | | | | | | | | | | | | | | | | | | | | | | | | | | | | | | | | | | | | | | | | | | | | | | | | | | | | | | | | |
| CMOL | Compressor Overload settings | A | | | | | | | | | | | | | | | | | | | | | | | | | | | | | | | | | | | | | | | | | | | | | | | | | | | | | | | | | | | | | | | | | | | | | | | | | | | | | | | | | | | | | | | | | | | | | | | | | | | | |
| | Compressor Oil Type | P.O.E | | | | | | | | | | | | | | | | | | | | | | | | | | | | | | | | | | | | | | | | | | | | | | | | | | | | | | | | | | | | | | | | | | | | | | | | | | | | | | | | | | | | | | | | | | | | | | | | | | | | |
| IFM | Indoor Fan Motor (3Ph) | KW | | | | | | | | | | | | | | | | | | | | | | | | | | | | | | | | | | | | | | | | | | | | | | | | | | | | | | | | | | | | | | | | | | | | | | | | | | | | | | | | | | | | | | | | | | | | | | | | | | | | |
| | Indoor Fan Motor (3Ph) Full Load Amps | 3.0 | | | | | | | | | | | | | | | | | | | | | | | | | | | | | | | | | | | | | | | | | | | | | | | | | | | | | | | | | | | | | | | | | | | | | | | | | | | | | | | | | | | | | | | | | | | | | | | | | | | | |
| IFCB | Indoor Fan Motor Circuit Breaker | A | | | | | | | | | | | | | | | | | | | | | | | | | | | | | | | | | | | | | | | | | | | | | | | | | | | | | | | | | | | | | | | | | | | | | | | | | | | | | | | | | | | | | | | | | | | | | | | | | | | | |
| | Indoor Fan Motor Overload settings | 6.2 | | | | | | | | | | | | | | | | | | | | | | | | | | | | | | | | | | | | | | | | | | | | | | | | | | | | | | | | | | | | | | | | | | | | | | | | | | | | | | | | | | | | | | | | | | | | | | | | | | | | |
| IFOL | Indoor Fan Motor Overload | A | | | | | | | | | | | | | | | | | | | | | | | | | | | | | | | | | | | | | | | | | | | | | | | | | | | | | | | | | | | | | | | | | | | | | | | | | | | | | | | | | | | | | | | | | | | | | | | | | | | | |
| | Indoor Fan Motor Capacitor | 6.5 | | | | | | | | | | | | | | | | | | | | | | | | | | | | | | | | | | | | | | | | | | | | | | | | | | | | | | | | | | | | | | | | | | | | | | | | | | | | | | | | | | | | | | | | | | | | | | | | | | | | |
| OFCB | Outdoor Fan Motor (1Ph) Full Load Amps | MFD | | | | | | | | | | | | | | | | | | | | | | | | | | | | | | | | | | | | | | | | | | | | | | | | | | | | | | | | | | | | | | | | | | | | | | | | | | | | | | | | | | | | | | | | | | | | | | | | | | | | |
| | Outdoor Fan Motor Circuit Breaker | A | | | | | | | | | | | | | | | | | | | | | | | | | | | | | | | | | | | | | | | | | | | | | | | | | | | | | | | | | | | | | | | | | | | | | | | | | | | | | | | | | | | | | | | | | | | | | | | | | | | | |
| | Running Amps (total) | 1.7 X 4 | | | | | | | | | | | | | | | | | | | | | | | | | | | | | | | | | | | | | | | | | | | | | | | | | | | | | | | | | | | | | | | | | | | | | | | | | | | | | | | | | | | | | | | | | | | | | | | | | | | | |
| | Max Running Amps | 16 | | | | | | | | | | | | | | | | | | | | | | | | | | | | | | | | | | | | | | | | | | | | | | | | | | | | | | | | | | | | | | | | | | | | | | | | | | | | | | | | | | | | | | | | | | | | | | | | | | | | |
| SPSCB | Single Phase Socket Circuit Breaker | A/Ph | | | | | | | | | | | | | | | | | | | | | | | | | | | | | | | | | | | | | | | | | | | | | | | | | | | | | | | | | | | | | | | | | | | | | | | | | | | | | | | | | | | | | | | | | | | | | | | | | | | | |
| CCB | Control Circuit Breaker | 31/25/75 | | | | | | | | | | | | | | | | | | | | | | | | | | | | | | | | | | | | | | | | | | | | | | | | | | | | | | | | | | | | | | | | | | | | | | | | | | | | | | | | | | | | | | | | | | | | | | | | | | | | |
| 24VCB | 24 Volt Circuit Breaker | A/Ph | | | | | | | | | | | | | | | | | | | | | | | | | | | | | | | | | | | | | | | | | | | | | | | | | | | | | | | | | | | | | | | | | | | | | | | | | | | | | | | | | | | | | | | | | | | | | | | | | | | | |
| | Weight-Nett | A | | | | | | | | | | | | | | | | | | | | | | | | | | | | | | | | | | | | | | | | | | | | | | | | | | | | | | | | | | | | | | | | | | | | | | | | | | | | | | | | | | | | | | | | | | | | | | | | | | | | |
| | | 2 | | | | | | | | | | | | | | | | | | | | | | | | | | | | | | | | | | | | | | | | | | | | | | | | | | | | | | | | | | | | | | | | | | | | | | | | | | | | | | | | | | | | | | | | | | | | | | | | | | | | |
| | | A | | | | | | | | | | | | | | | | | | | | | | | | | | | | | | | | | | | | | | | | | | | | | | | | | | | | | | | | | | | | | | | | | | | | | | | | | | | | | | | | | | | | | | | | | | | | | | | | | | | | |
| | | 2 | | | | | | | | | | | | | | | | | | | | | | | | | | | | | | | | | | | | | | | | | | | | | | | | | | | | | | | | | | | | | | | | | | | | | | | | | | | | | | | | | | | | | | | | | | | | | | | | | | | | |
| | | Kg | | | | | | | | | | | | | | | | | | | | | | | | | | | | | | | | | | | | | | | | | | | | | | | | | | | | | | | | | | | | | | | | | | | | | | | | | | | | | | | | | | | | | | | | | | | | | | | | | | | | |
| | | 445 | | | | | | | | | | | | | | | | | | | | | | | | | | | | | | | | | | | | | | | | | | | | | | | | | | | | | | | | | | | | | | | | | | | | | | | | | | | | | | | | | | | | | | | | | | | | | | | | | | | | |
| B | <p>Client Wiring</p> | | | | | | | | | | | | | | | | | | | | | | | | | | | | | | | | | | | | | | | | | | | | | | | | | | | | | | | | | | | | | | | | | | | | | | | | | | | | | | | | | | | | | | | | | | | | | | | | | | | | | |
| C | <p>Client Wiring</p> | | | | | | | | | | | | | | | | | | | | | | | | | | | | | | | | | | | | | | | | | | | | | | | | | | | | | | | | | | | | | | | | | | | | | | | | | | | | | | | | | | | | | | | | | | | | | | | | | | | | | |
| D | <p>Client Wiring</p> | | | | | | | | | | | | | | | | | | | | | | | | | | | | | | | | | | | | | | | | | | | | | | | | | | | | | | | | | | | | | | | | | | | | | | | | | | | | | | | | | | | | | | | | | | | | | | | | | | | | | |
| E | <p>Client Wiring</p> | | | | | | | | | | | | | | | | | | | | | | | | | | | | | | | | | | | | | | | | | | | | | | | | | | | | | | | | | | | | | | | | | | | | | | | | | | | | | | | | | | | | | | | | | | | | | | | | | | | | | |
| F | <p>Client Wiring</p> | | | | | | | | | | | | | | | | | | | | | | | | | | | | | | | | | | | | | | | | | | | | | | | | | | | | | | | | | | | | | | | | | | | | | | | | | | | | | | | | | | | | | | | | | | | | | | | | | | | | | |
| G | <table border="1"> <thead> <tr> <th>REV</th> <th>DESCRIPTION</th> <th>ECN</th> <th>DATE</th> <th>APPROVED</th> </tr> </thead> <tbody> <tr> <td>D</td> <td>NOTE & LINKS ADDED</td> <td>N3383</td> <td>03-10-13</td> <td>C.M.W.</td> </tr> <tr> <td>E</td> <td>REFER SHEET 2</td> <td>N3649</td> <td>28-01-15</td> <td>R.A.S.</td> </tr> <tr> <td>H</td> <td>Wiring detail notice updated</td> <td>N3966</td> <td>18-09-18</td> <td>I.I.M.</td> </tr> <tr> <td>G</td> <td>Oil 10ml to 20ml. RCBO to SPSCB. Eth upd.</td> <td>N3922</td> <td>10-04-17</td> <td>T.N.M.</td> </tr> </tbody> </table> | | | | | | | | | REV | DESCRIPTION | ECN | DATE | APPROVED | D | NOTE & LINKS ADDED | N3383 | 03-10-13 | C.M.W. | E | REFER SHEET 2 | N3649 | 28-01-15 | R.A.S. | H | Wiring detail notice updated | N3966 | 18-09-18 | I.I.M. | G | Oil 10ml to 20ml. RCBO to SPSCB. Eth upd. | N3922 | 10-04-17 | T.N.M. | | | | | | | | | | | | | | | | | | | | | | | | | | | | | | | | | | | | | | | | | | | | | | | | | | | | | | | | | | | | | | | | | | | | |
| REV | DESCRIPTION | ECN | DATE | APPROVED | | | | | | | | | | | | | | | | | | | | | | | | | | | | | | | | | | | | | | | | | | | | | | | | | | | | | | | | | | | | | | | | | | | | | | | | | | | | | | | | | | | | | | | | | | | | | | | | | | |
| D | NOTE & LINKS ADDED | N3383 | 03-10-13 | C.M.W. | | | | | | | | | | | | | | | | | | | | | | | | | | | | | | | | | | | | | | | | | | | | | | | | | | | | | | | | | | | | | | | | | | | | | | | | | | | | | | | | | | | | | | | | | | | | | | | | | | |
| E | REFER SHEET 2 | N3649 | 28-01-15 | R.A.S. | | | | | | | | | | | | | | | | | | | | | | | | | | | | | | | | | | | | | | | | | | | | | | | | | | | | | | | | | | | | | | | | | | | | | | | | | | | | | | | | | | | | | | | | | | | | | | | | | | |
| H | Wiring detail notice updated | N3966 | 18-09-18 | I.I.M. | | | | | | | | | | | | | | | | | | | | | | | | | | | | | | | | | | | | | | | | | | | | | | | | | | | | | | | | | | | | | | | | | | | | | | | | | | | | | | | | | | | | | | | | | | | | | | | | | | |
| G | Oil 10ml to 20ml. RCBO to SPSCB. Eth upd. | N3922 | 10-04-17 | T.N.M. | | | | | | | | | | | | | | | | | | | | | | | | | | | | | | | | | | | | | | | | | | | | | | | | | | | | | | | | | | | | | | | | | | | | | | | | | | | | | | | | | | | | | | | | | | | | | | | | | | |

NOTE
The manufacturer reserves the right to change specifications at any time without notice or obligation. Certified dimensions available on request.

This pamphlet replaces the previous issue no. 3478 dated 05/17. Wiring rev. H.

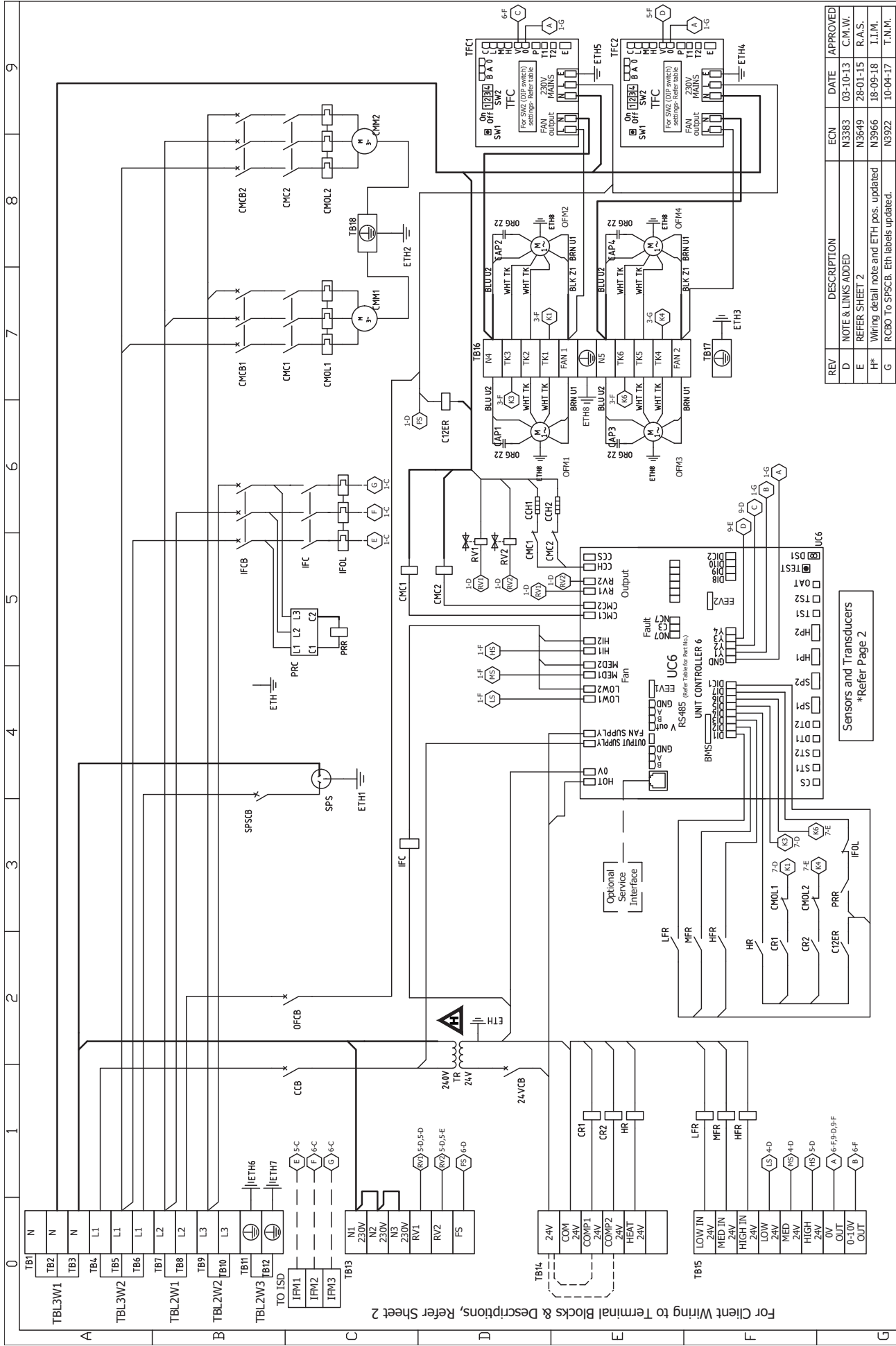

| REV | DESCRIPTION | ECN | DATE | APPROVED |
|-----|---|-------|----------|----------|
| D | NOTE & LINKS ADDED | N3383 | 03-10-13 | C.M.W. |
| E | REFER SHEET 2 | N3649 | 28-01-15 | R.A.S. |
| F* | Wiring detail note and ETH pos. updated | N3966 | 18-09-18 | I.I.M. |
| G | RCBO To SPSCB. Eth labels updated. | N3922 | 10-04-17 | T.N.M. |

| | |
|----------------------|------------------|
| Rev: | H |
| Drawing No: | OSA 465RKTBV |
| Title: | Wiring Schematic |
| Drawn: | J.S.L. |
| Date: | 23-01-13 |
| Client Wiring | _____ |
| DO NOT SCALE - ASK | _____ |
| ©temperzone Ltd 2013 | _____ |

