

OPA 170RKTH

Packaged Reverse Cycle R410A Air Cooled Air Conditioner

Installation & Maintenance

GENERAL

This OPA 170 unit must be installed in accordance with all national and local safety codes.

OPTION (Field Fitted)

1. SAT-2 Controller 230V kit
2. Electric heat kit.

INSTALLATION

Positioning

Refer to dimension diagram for minimum clearances. If multiple units are to be placed side-by-side then allow at least 2 m between coil faces.

Mounting

Fasten the unit down to a firm flat horizontal base using the four holes provided in the mounting rails.

When the unit is being installed on a roof it is recommended that the unit is installed on a substantial structure with vibration isolating springs beneath the unit. These springs are not supplied with the unit.

Flexible duct connections are recommended between the supply and return ducts and the unit.

Condensate Drain

The condensate drain should be 'U' trapped outside the unit. The trap should have a vertical height of at least 50 mm. The drain should have a slope of at least 1 in 50 and must not be piped to a level above the unit drain pipe.

For long condensate pipe runs, fit a vent pipe near the drain trap. The top of the vent pipe must be at least 100 mm above the OPA unit's drain tray.

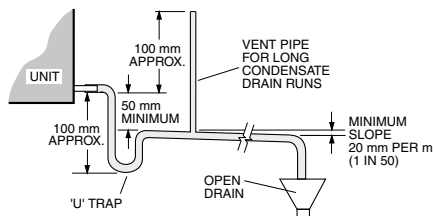

REFRIGERATION SYSTEM

General

The refrigeration system has been charged with R410A refrigerant; refer wiring specification table for amount. Tapping points are provided to measure discharge and suction operating pressures. Beware of high system pressures; use correct gauges.

Compressor

The compressor is directional scroll type. The compressor lubricant is polyol ester oil (POE). Note, this oil absorbs moisture quickly if exposed to open air. On commissioning, the compressor must be checked for correct rotation (refer Start Up Procedure).

ELECTRICAL REQUIREMENTS

Electrical work must be done by a qualified electrician. The outdoor unit must be wired directly from a distribution board by means of a circuit breaker or H.R.C. fuse, and a mains isolator provided - preferably close to the unit.

Note: DO NOT USE REWIRABLE FUSES.

Standard units are suitable for use with thermostats with either manual Heat/Cool selection or automatic changeover subject to the contact ratings of the thermostats.

Refer to separate pamphlet for approved thermostats, or contact the manufacturer's nearest sales office.

A 24 hour power supply to the crankcase heaters is required, otherwise the warranty is void.

CHECK TESTS

1. Leave the remote switch in the off position and close the mains isolating switch.
A four hour delay period is required to allow the crankcase heater to drive any liquid refrigerant out of the compressor oil. Bypass the crankcase heater thermostat (CCHT) for this period only.
2. Check that all fan motors are free running.
3. Check that the thermostat is correctly wired to the unit and is set at the desired temperature.
4. Check that the air filters, if any, have been correctly installed.
5. Check any supply air diffuser dampers are open.

START UP PROCEDURE

Use the supplied Commissioning Sheet to help you complete the following procedure:

1. Switch on the unit after the four hour delay period for the crankcase heater has expired. Ensure the crankcase heater thermostat has been reconnected.
2. Check for correct rotation of the compressor. If rotation is incorrect the compressor will not pump, be noisy, and will draw minimal current. To correct motor rotation, change the phasing at the main power terminal.

3. Check the supply voltage.
4. Measure the current draw on the compressor motor and on each fan motor. Check all readings against the specified values - particularly the indoor fan amps if the unit is installed in a free blow application.
5. Fit R410A compatible gauges and measure the suction and discharge pressures.
6. Test the operation of the high pressure safety control by switching off the outdoor air fan.
7. Test the operation of the reversing valve by running the unit in both the heating and cooling mode.
8. Check that the motors are running smoothly.
9. Check the supply air flow at each outlet.
10. Touch up any outdoor unit paintwork damage to prevent corrosion.

OUTDOOR UNIT CONTROLLER (OUC)

The Outdoor Unit Controller (OUC) includes a temperature sensing head pressure control which enables the system to compensate for outdoor ambient temperatures below 20°C on cooling cycle, and above 15°C on heating cycle. The OUC also has features which protect against icing or overheating of coils, rapid cycling of the compressor and loss of refrigerant charge.

If the outdoor unit fans take some time to begin rotating when the system is powered on, or they don't appear to be rotating appropriately while the compressor is running, consult the OUC label on the electrical box. If necessary, refer to **temperzone** for further diagnostic information.

MAINTENANCE

Weekly For First Four Weeks

1. Check indoor air filters (if fitted) and vacuum or wash clean as necessary.
2. Check condensate drain for free drainage.
3. Check compressor compartment for oil stains indicating refrigerant leaks.
4. Check tightness of electrical connections.

Six Monthly

1. Check the tightness of all fan and motor mountings.
2. Check tightness of electrical connections.
3. Check suction and discharge operating pressures.
4. Replace indoor unit air filters (if fitted).
5. Check condensate drain for free drainage.

Yearly

1. Check all refrigerant piping for chafing and vibration.
2. Check the operation of electric heaters, if fitted.
3. Check air supply at all diffusers.
4. Check for excessive noise and vibration and correct as necessary.
5. Check for insulation and duct damage and repair as necessary.
6. Remove lint and dust accumulation from outdoor coil fins.
7. Touch up any outdoor unit paintwork damage to prevent corrosion.

NOTE

The manufacturer reserves the right to change specifications at any time without notice or obligation. Certified dimensions available on request.

This pamphlet replaces the previous issue no. 3488 dated 10/10. Wiring revision G.

Dimensions (mm)

OPA 170RKTH

Not to Scale

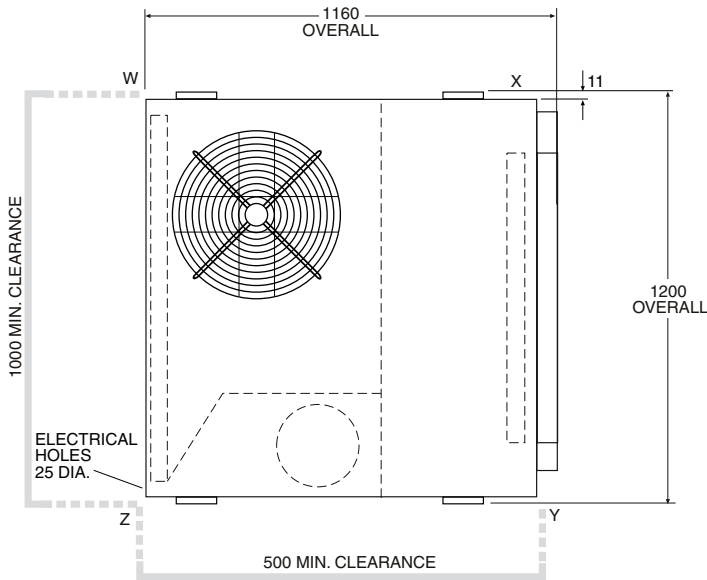
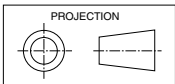

POINT LOADS (kg)				WEIGHT (kg)
W	X	Y	Z	
44	51	69	55	219

