

ISD 86–235 KY-D (c/w EC motor & SAT-2 Controller)

Ducted Split System Indoor Units

Installation & Maintenance

Fig. 1 Dimensions (mm)

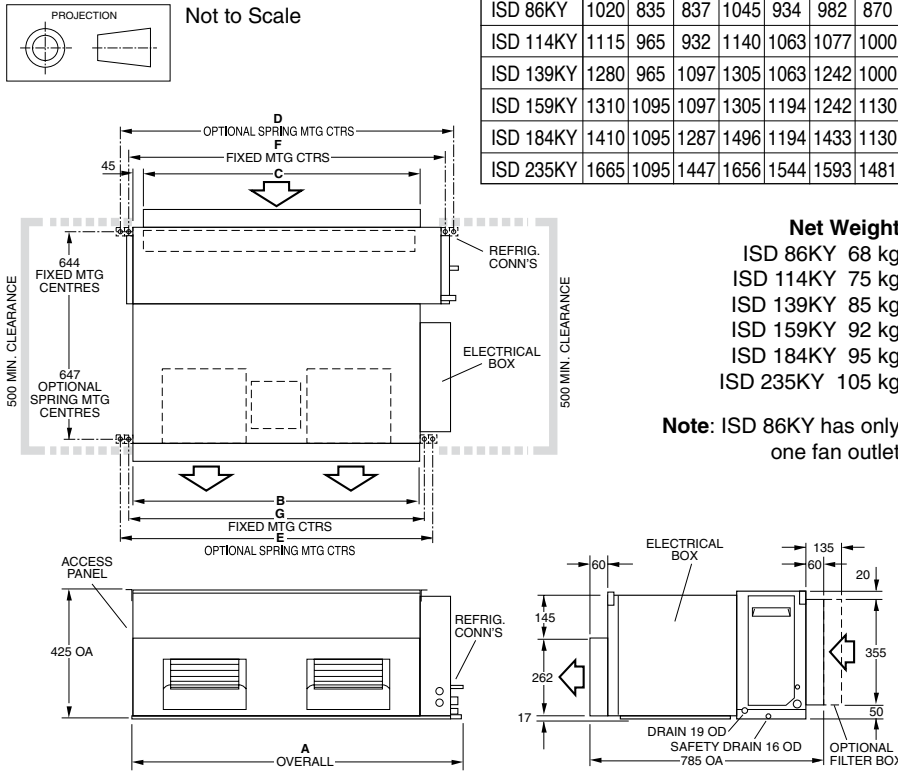

GENERAL

These ISD*KY-D indoor units are designed to be coupled with the OSA*RK outdoor units. The '-D' indicates the unit is supplied complete with SAT-2 room temperature controller.

Units must be installed in accordance with all national and local safety codes.

Combinations

- One ISD 86KY with one OSA 86RKSH
- One ISD 114KY with one OSA 114RKSH
- One ISD 114KY with one OSA 114RKTH
- One ISD 139KY with one OSA 139RKSH
- One ISD 139KY with one OSA 139RKTH
- One ISD 159KY with one OSA 159RKSH
- One ISD 159KY with one OSA 159RKTH
- One ISD 184KY with one OSA 184RKTH
- One ISD 184KY with one OSA 184RKTV
- One ISD 235KY with one OSA 235RKTH
- One ISD 235KY with one OSA 235RKTV

Options

- Filter Box c/w polypropylene net filter
- Spring Mounting Kit
- Supply & Return Air Plenums
- SAT-2 Accessories (refer overleaf)
- Spigot Plate Adaptor
 - ISD 86KY: Ø350 mm (2 inlets)
 - ISD 114/139 KY: Ø400 mm (2 inlets)
 - ISD 159/184 KY: Ø450 mm (2 inlets)
 - ISD 235KY: Ø300 mm (4 inlets)

Fig. 2 Separable (Option)

Separable for ease of installation through small man holes – minimum 550 mm sq. clear aperture

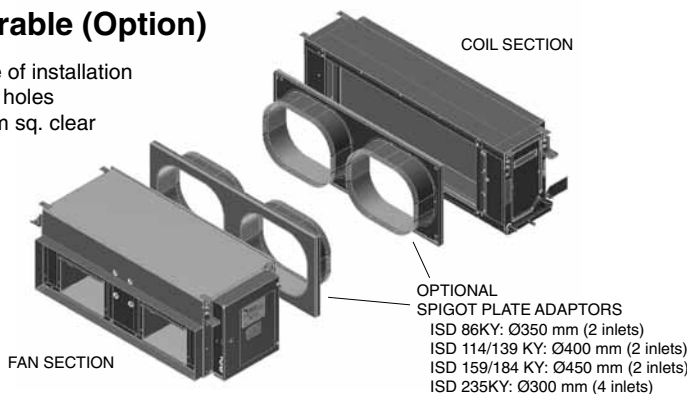

SAFETY DRAIN TRAY

The unit is supplied with an in-built safety drain tray to protect your ceiling against accidental damage.

AIR FILTRATION / FILTER BOX (Option)

As air filtration requirements vary, filters are not supplied with the unit. Filters should ideally be installed on the return air side of the unit, no closer than 500mm from the back of the unit and easily accessible for cleaning. To maximise the efficiency of air flow, the return air filter should be twice the area of the ISD unit's return air spigot/s. If efficiency is less of a concern a Filter Box is available.

Fig. 3 Spring Mounting

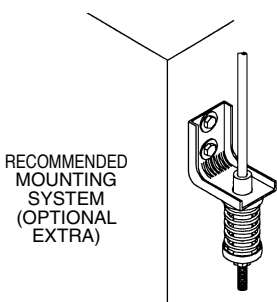
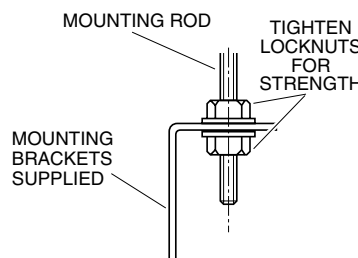

Fig. 4 Solid Mounting



The Filter Box is installed by sliding it over the return air spigot and screwing it in place. The filter may be accessed from either side of this spigot. This new spigot has a depth of 135 mm, instead of 60 mm.

SEPARABLE (Option)

Each model is made up of two parts, a fan section and a coil section (refer fig.2). To separate, undo the screws holding the two parts together. Disconnect the two sensor wires that run between the two parts at the control board. Remember to reconnect

these two wires to the same place when re-assembling. Make sure the contact seals are tightly sealed all the way around when reassembling the two sides.

It may be desirable in some applications to keep the two separate parts of the unit apart and joined by ducting, eg over a ceiling joist. A pair of the optional Spigot Plate Adaptors are available to facilitate this option.

INSTALLATION

Positioning & Mounting

Provide 500 mm minimum clearance to both ends of the unit.

If low noise is a critical factor in the installation, refer to Figure 6 for noise isolation recommendations.

It is recommended that the unit be mounted using the spring mounting system, supplied as an optional extra (Fig.7). This system minimises transfer of vibration into the building structure.

If a more rigid installation can be tolerated, then suspend the unit from four threaded rods (not supplied) attached to the ceiling. Four 'L' shaped brackets are supplied on the unit to facilitate this method. These brackets must first be unscrewed, reversed and resecured to enable rod attachment.

The unit has a built-in sloping drain tray, therefore mount it level.

When finally positioned, tighten the lock nuts on the mounting rods from above and below the mounting flange to give a firm installation (see Fig. 4).

Condensate Drains

The condensate drain should be trapped outside the unit cabinet. The trap should have a vertical height of at least 50 mm. The drain should have a slope of at least 1 in 50 and must not be piped to a level above the unit drain tray. (Refer Fig.5).

For long condensate pipe runs, fit a vent pipe near the drain trap. The top of the vent pipe must be at least 100 mm above the ISD unit's drain tray.

It is essential that the drainage system for the evaporator is checked by pouring water in the drain tray and seeing that it discharges at the end of the drain and does not overflow the drain tray.

Connect the safety drain tray drain pipe to a suitable drain line with an appropriate slope to allow free drainage. This drain line does not require trapping. Test the drain with water to ensure it clears safely.

INDOOR-OUTDOOR UNIT CONNECTIONS

Refer to the relevant OSA Outdoor Unit 'Installation & Maintenance' pamphlet for piping instructions. For wiring connections, refer to the Outdoor Unit wiring diagram in conjunction with the ISD wiring diagram in this pamphlet.

REFRIGERATION PIPING

Pipe Connection Sizes (mm OD) & Type

Model	Liquid	Suction
ISD 86KY	10 (3/8") sweat	16 (5/8") sweat
ISD 114KY	10 (3/8") sweat	16 (5/8") sweat
ISD 139KY	10 (3/8") sweat	19 (3/4") sweat
ISD 159KY	13 (1/2") sweat	22 (7/8") sweat
ISD 184KY	13 (1/2") sweat	22 (7/8") sweat
ISD 235KY	13 (1/2") sweat	22 (7/8") sweat

Fig. 5

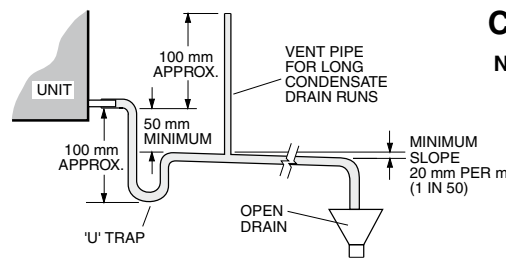

Condensate Drain

Note: The Safety Drain Tray does not require trapping.

The ISD is shipped from the factory with a pressurised holding charge of nitrogen. Immediately before removing any brazed pipe connection's seal, reduce the holding charge to atmospheric pressure.

Warning: Failure to do so may cause injury.

Refer to the Outdoor Unit 'Installation & Maintenance' pamphlet for evacuation procedure and piping requirements.

ELECTRICAL WIRING

The electrical supply required (via the Outdoor Unit) is specified on the Outdoor Unit's wiring diagram.

Electrical work must be carried out by a qualified electrician in accordance with local supply authority regulations and the wiring diagram.

In a free blow or low resistance application, beware of exceeding the fan motor's full load amp limit (refer Outdoor Unit's wiring diagram).

Note: The SAT-2 Controller automatically switches the indoor fan off during de-ice, therefore no additional wiring is required to achieve this result.

INDOOR FAN SPEED

The fan speed (RPM) range is adjustable using DIP2 Switches 1 to 5 on the EC Motor Controller board located in the electrical box – refer wiring diagram. The default setting is highlighted.

Once set, your fan speed range can then be set to: LOW, MED and HIGH (DIP1 switch 1 'OFF') across the selected range.

If the air returning to the indoor unit is regularly expected to be above 50%RH, then the coil face velocity should be limited to be 2.5 m/s or less (refer Air Handling graph in Technical Data pamphlet).

High humidity levels can occur in tropical or subtropical conditions, and/or when heavily moisture laden fresh air is introduced. Select a fan speed that avoids water carry-over problems.

SAT-2 CONTROLLER

The following components are supplied in a box taped inside the return air spigot:

- SAT-2 Wall Control plaque, including wall mounting plate.
- 10 m interface lead (electrical box-to-plaque).
- User's Operating Instructions booklet.
- Lithium CR2032 battery (3V).

Optional

- Remote return air sensor (in box).
- Remote return air temperature sensor lead; 1.5, 6, 12 or 25 m.
- 20 m extended interface lead (electrical box-to-plaque).

- ISD indoor unit-to-OSA outdoor unit interconnecting lead; 12.5 m or 25 m; 7 core.
- SAT-2 Zone Control PCB.
- Zone Control 24V transformer.
- Additional SAT-2 Wall Control plaque.
- Infra red remote control.

Installation

The SAT-2 Controller PCB is supplied pre-installed in the ISD unit's electrical box.

- Isolate the ISD unit from power supply, then remove electrical box cover.
- Remove the SAT-2 box supplied taped inside the return air spigot.
- Remove the Wall Control's interface lead from this box and connect the bare wired end of the interface lead to the terminal block on the SAT-2 Controller board (refer wiring diagram). Trace the remaining length of the lead to the Wall Control's intended location.
- Remove the Wall Control's backing plate by using a small screw driver to remove the single screw at the bottom edge of the plaque.
- Install the Lithium battery, supplied loose, positive (+) side up in the Wall Control's battery holder.
- Check the wall where the Wall Control plaque is to be located is flat before fastening the wall mounting plate. Alternatively, the mounting plate can be screwed to a standard wall socket mounted horizontally.

Note: Use low profile (mush) headed screws to prevent contact with the PCB board. Fixing the plate to a distorted surface may damage the control.
- Drill hole in wall to allow cable entry.
- Connect the interface lead's lugs to the Wall Control board as per the wiring diagram overleaf.
- Ensure the interface lead is run separately and away from main power supply wires, including the interconnecting cable. When installing cabling, trim any excess length to suit your location.
- Fill around the interface lead with foam or cover hole with PVC tape to prevent draft from wall cavity affecting control operation. Do not use aluminium duct tape.
- Secure the Wall Control body to the mounting plate by replacing the locking screw removed earlier.
- Replace the ISD electrical box cover.

Remote Air Temperature Sensor/s (option)

The air temperature sensor is by default located in the Wall plaque. Optional remote air temperature sensors are available so that the measurement of the room temperature can be taken away from the wall plaque, eg. elsewhere in the room or in the return air duct.

Remote sensor's can be plugged directly into the Controller board (PCB). This board accepts up to four sensors which are designated as 'zones' one to four. The first return air sensor will automatically replace the Wall Control sensor and should be located in the same room as the Wall Control.

The Controller will always use the average of the zones selected. Refer to the separate installation instructions supplied with the PCB for further details.

Ensure all remote sensor wires are run separately and away from main power supply wires, including the interconnecting cable.

COMMISSIONING

Indoor Unit

1. Check that the thermostat is correctly wired and set at the desired temperature.
2. Check that the air filter (if fitted) is clean.

3. Check that the fan runs freely without vibration.
4. Check condensate drain and safety drain tray for free drainage.

Refer to Outdoor Unit Installation Instructions in order to complete the start-up and commissioning procedure for the complete air conditioning system.

Demonstrate the SAT-2 Wall Control to the owner/user, after having first thoroughly familiarised yourself with the User's Operating Instructions. This page is to remain with the owner/user.

MAINTENANCE

Weekly For First Four Weeks

1. Check air filter (if fitted); vacuum clean as necessary.
2. Check condensate drain for free drainage.

Monthly

Check air filter (if fitted); vacuum clean as necessary.

Six Monthly

1. Check condensate drain and safety drain tray for free drainage.
2. Check heat exchanger coil; vacuum or brush clean as necessary.
3. Check the tightness of the fan.
4. Check that fan motor is free running.
5. Check tightness of electrical connections.
6. Check air supply at diffuser outlets.

WARNING

This unit is designed for use ONLY with the refrigerant HFC-410A (R410A). The use of other refrigerants is NOT authorised or approved by the manufacturer and may cause operational problems such as poor performance and efficiency, loss of capacity, degradation of materials and refrigerant leaks.

The use of flammable or explosive materials as a refrigerant creates the additional risks of fire and explosion which may result in property damage, personal injury or death.

Fig. 6 SAT-2 Control Wiring

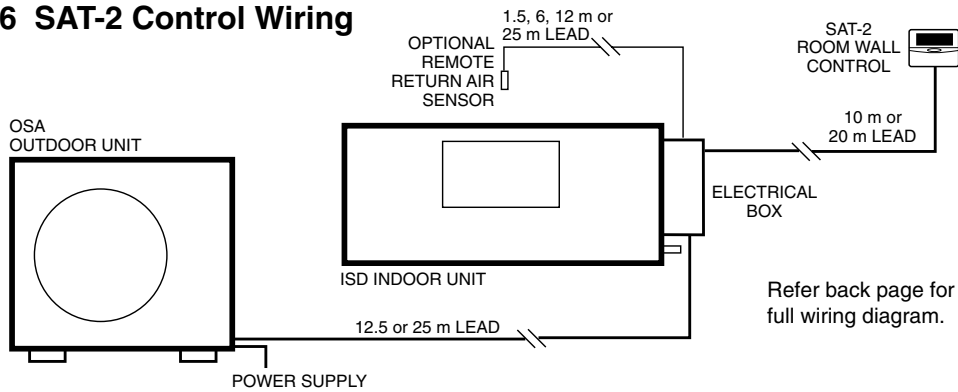

NOTE

The manufacturer reserves the right to change specifications at any time without notice or obligation. Certified dimensions available on request.

This pamphlet replaces the previous issue no. 3797 dated 05/12. Wiring revision C.

Refer back page for full wiring diagram.

Fig. 7 Application Considerations

Recommendations for Noise Isolation

- particularly for high static installations:

1. Avoid installing units, with non-ducted return air, directly above spaces where noise is critical.
2. Use flexible connections between unit and rigid ducting.
3. Use generously sized acoustically lined ducts.
4. If generous duct size is not possible, use turning vanes on bends to reduce air turbulence (regenerated noise).
5. Use 90° bends in ducting to significantly assist in noise reduction.

