

ISDL 86/114 KY (c/w EC Motor)

Ducted Split System Indoor Units

Installation & Maintenance

Fig. 1 Dimensions (mm)

MODEL	A	B	C	D	Net Weight	Spigots
ISDL 86KY	1565	1319	1350	1408	63 kg	250 dia. (x8)
ISDL 114KY	1785	1539	1570	1628	67 kg	250 dia. (x8)

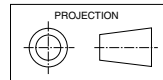

Not to Scale

ISDL 86KY shown here

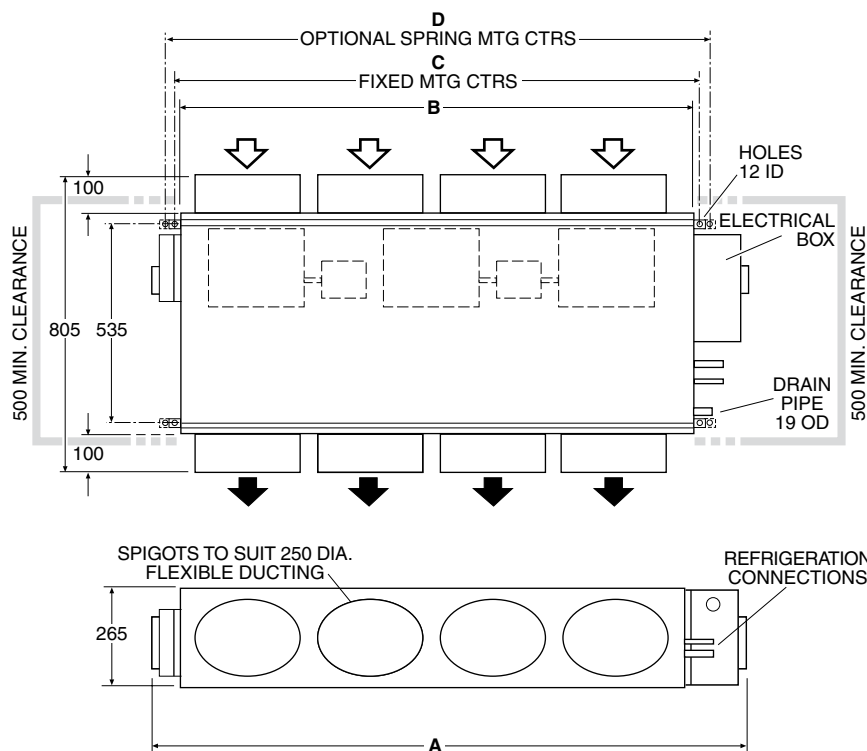

NOTE

The manufacturer reserves the right to change specifications at any time without notice or obligation. Certified dimensions available on request.

GENERAL

These ISDL*KY indoor units are designed to be coupled with the OSA*RK outdoor units. Units must be installed in accordance with all national and local safety codes.

Combinations

- One ISDL 86KY with one OSA 86RKSH
- One ISDL 114KY with one OSA 114RKSH
- One ISDL 114KY with one OSA 114RKTH

Options

1. Filter Box
2. Spring Mounting Kit

AIR FILTRATION / FILTER BOX (Option)

As air filtration requirements vary, filters are not supplied with the unit. Filters should ideally be installed on the return air side of the unit, no closer than 500 mm from the back of the unit and easily accessible for cleaning. To maximise the efficiency of air flow, the return air filter should be twice the area of the ISD unit's return air spigot/s. If efficiency is less of a concern a Filter Box is available.

The Filter Box fits between the ISDL's return air spigot plate and the main chassis. This addition adds 95 mm to the depth of the unit. The filter may be accessed from either side of the box.

INSTALLATION

Positioning & Mounting

Provide 500 mm minimum clearance to the both ends of the unit. Allow adequate clearance for the filter to be withdrawn to its full length from either end of the unit. Alternatively the filter may be lifted out of its track.

It is recommended that the unit be mounted using the spring mounting system, supplied as an optional extra (Fig.2). This system minimises transfer of vibration into the building structure.

If a more rigid installation can be tolerated, then suspend the unit from four threaded rods (not supplied) and use locknuts (not supplied), as shown in Figure 3. The 'L' shaped brackets, supplied on the unit's corners, must first be unscrewed and reversed to allow rod insertion.

Alternatively mount each unit on vibration isolators on a suitable platform.

The unit has a built in sloping drain tray so mount it level.

Fig. 2 Spring Mounting

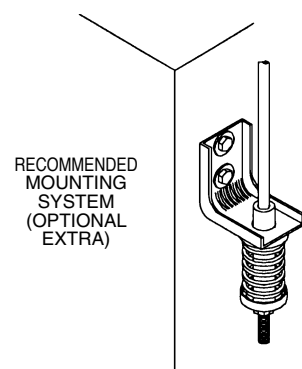

Fits in same position as brackets supplied with unit.

Fig. 3 Solid Mounting

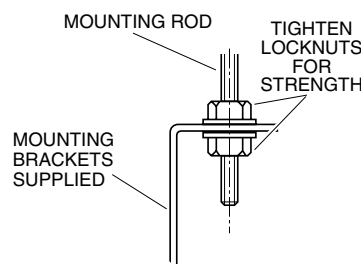

Condensate Drain

The drain should have a slope of at least 1 in 50 and must not be piped to a level above the unit drain tray. Fit a vent pipe within 500 mm of the unit. Check the drain by pouring water into the drain tray and ensuring that it clears.

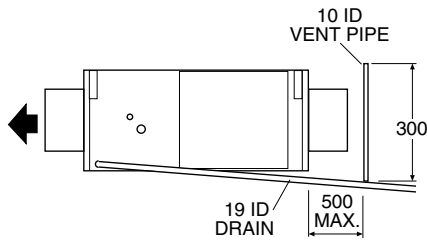

INDOOR-OUTDOOR UNIT CONNECTIONS

Refer to the relevant OSA Outdoor Unit 'Installation & Maintenance' pamphlet for piping instructions.

For wiring connections, refer to the Outdoor Unit wiring diagram in conjunction with the ISDL wiring diagram on this pamphlet.

REFRIGERATION PIPING

Pipe Connection Sizes (mm OD)

Liquid: 10 ($\frac{3}{8}$ " sweat)

Suction: 16 ($\frac{5}{8}$ " sweat)

ISDL units are shipped from the factory with a pressurised holding charge of nitrogen. Immediately before removing any brazed pipe connection's seal, reduce the holding charge to atmospheric pressure.

Warning: Failure to do so may cause injury.

Refer to the Outdoor Unit 'Installation & Maintenance' pamphlet for evacuation procedure and piping requirements.

ELECTRICAL WIRING

The electrical supply required (via the Outdoor Unit) is specified on the Outdoor Unit's wiring diagram. Electrical work must be carried out by a qualified electrician in accordance with local supply authority regulations and the wiring diagram.

In a free blow or low resistance application, beware of exceeding the fan motor's full load amp limit (refer Outdoor Unit's wiring diagram).

It is recommended electricians run a spare wire between Outdoor Unit and Indoor Unit in case 'Indoor Fan Off During De-Ice' becomes a requirement. Leave this spare wire unconnected until required. If and when this option is required, the loop wire must be removed between terminals 'N' and '1'.

INDOOR FAN SPEED

The indoor fan speed can be 'Stepped' or 'Continuously Variable'. The choice is made using Switch 1 of 'DIP1' on the EC Motor Controllers (one at each end of the unit). Switches 1 to 5 on 'DIP2' determine the minimum and maximum fan speeds.

The same 'Minimum rpm' and 'Maximum rpm' settings apply to 'Stepped' and 'Continuously Variable'.

The default settings for DIP1 and DIP2 are highlighted on the Wiring Schematic.

- 1. Stepped (DIP1 switch 1 = OFF)**
Connecting the 24V AC power from the unit's 'HOT 24V' terminal to one (and only one at a time) of the 'LOW 24V' / 'MED 24V' / 'HIGH 24V' terminals, selects the 'LOW' (Min. rpm), 'HIGH' (Max. rpm), or 'MED' (mid-way between) fan speed. The transitions between speeds are smooth.
- 2. Continuously Variable (DIP1 switch 1=ON)**
When using this method a temperzone Analog Signal Isolator (No. 201-000-129) must be fitted and connected as shown in the wiring schematic. 24V AC or DC power from the external (BMS) controller should be provided to the '24V' and '0V' input terminals of the Signal Isolator board.

A voltage below 2V DC applied across the '0V' and the '0-10V' input terminals (labelled 'From BMS Controller' in the wiring schematic) of the Signal Isolator will stop the indoor fan. A control voltage of slightly more than 2V will cause the fan to run at the 'Min. rpm' speed. A 10V DC signal will run the fan at the 'Max. rpm' speed. Control voltages between these two limits can be used to achieve any desired speed between 'Min.' and 'Max.' rpm.

Do not use switch combinations marked with 'DO NOT USE' in the Speed Selection table.

If the air returning to the indoor unit is regularly expected to be above 50%RH, then the coil face velocity should be limited to be 2.5 m/s or less (refer Air Handling graph in Technical Data pamphlet).

High humidity levels can occur in tropical or subtropical conditions, and/or when heavily moisture laden fresh air is introduced. Select a fan speed that avoids water carry-over problems.

THERMOSTATS

A dedicated neutral line is required where electronic or anticipator thermostats are used when you choose to have indoor fan off in de-ice. Refer to **temperzone** for recommended thermostats.

COMMISSIONING

Indoor Unit

1. Check that the thermostat is correctly wired and set at the desired temperature.
2. Check that the air filter is clean.
3. Check that the fan runs freely without vibration.
4. Check condensate drain for free drainage.
5. Run the unit in cooling and heating modes.

MAINTENANCE

Weekly For First Four Weeks

1. Check air filter (if fitted); vacuum clean as necessary.
2. Check condensate drain for free drainage.

Monthly

Check air filter (if fitted); vacuum clean as necessary.

Six Monthly

1. Check condensate drain for free drainage.
2. Check heat exchanger coil; vacuum or brush clean as necessary.
3. Check the tightness of the fan.
4. Check that fan motor is free running.
5. Check tightness of electrical connections.
6. Check air supply at diffuser outlets.

WARNING

This unit is designed for use ONLY with the refrigerant HFC-410A (R410A). The use of other refrigerants is NOT authorised or approved by the manufacturer and may cause operational problems such as poor performance and efficiency, loss of capacity, degradation of materials and refrigerant leaks.

The use of flammable or explosive materials as a refrigerant creates the additional risks of fire and explosion which may result in property damage, personal injury or death.

Note

The manufacturer reserves the right to change specifications at any time without notice or obligation. Certified dimension available on request.

