

# ISD 235KY-DL (c/w EC motor, SAT-2 Controller & Zone Control)

## Ducted Split System Indoor Units

## Installation & Maintenance

### GENERAL

These ISD 235KY indoor units are designed to be coupled with the OSA 235RKT outdoor units. Units must be installed in accordance with all national and local safety codes.

### Options

1. Filter Box c/w polypropylene net filter
2. Spring Mounting Kit
3. Spigot Plate Adaptor: Ø300mm (4 spigots)

### SAFETY DRAIN TRAY

The unit is supplied with an in-built safety drain tray to protect your ceiling against accidental damage.

### AIR FILTRATION / FILTER BOX (Option)

As air filtration requirements vary, filters are not supplied with the unit. Filters should ideally be installed on the return air side of the unit, no closer than 500mm from the back of the unit and easily accessible for cleaning. To maximise the efficiency of air flow, the return air filter should be twice the area of the ISD unit's return air spigot/s. If efficiency is less of a concern a Filter Box is available.

The Filter Box is installed by sliding it over the return air spigot and screwing it in place. The filter may be accessed from either side

of this spigot. This new spigot has a depth of 135 mm, instead of 60 mm.

### SEPARABLE (Option)

Each model is made up of two parts, a fan section and a coil section (refer fig.2). Separation permits ease of installation through small man holes (minimum 550 mm sq. clear aperture). To separate, undo the screws holding the two parts together. Disconnect the two sensor wires that run between the two parts at the control board. Remember to reconnect these two wires to the same place when re-assembling. Make sure the contact seals are tightly sealed all the way around when reassembling the two sides.

It may be desirable in some applications to keep the two separate parts of the unit apart and joined by ducting, eg over a ceiling joist. A pair of the optional Spigot Plate Adaptors are available to facilitate this option. Two additional fixed mounting brackets are supplied with each adaptor.

### INSTALLATION

#### Positioning & Mounting

Provide 500 mm minimum clearance to both ends of the unit.

If low noise is a critical factor in the installation, refer to Figure 6 for noise isolation recommendations.

It is recommended that the unit be mounted using the spring mounting system, supplied as an optional extra (Fig.7). This system minimises transfer of vibration into the building structure.

If a more rigid installation can be tolerated, then suspend the unit from four threaded rods (not supplied) attached to the ceiling. Four 'L' shaped brackets are supplied on the unit to facilitate this method. These brackets must first be unscrewed, reversed and resecured to enable rod attachment.

The unit has a built-in sloping drain tray, therefore mount it level.

When finally positioned, tighten the lock nuts on the mounting rods from above and below the mounting flange to give a firm installation (see Fig. 4).

### Condensate Drains

The condensate drain should be trapped outside the unit cabinet. The trap should have a vertical height of at least 50 mm. The drain should have a slope of at least 1 in 50 and must not be piped to a level above the unit drain tray. (Refer Fig.5).

Fig. 1 Dimensions (mm)

Not to Scale

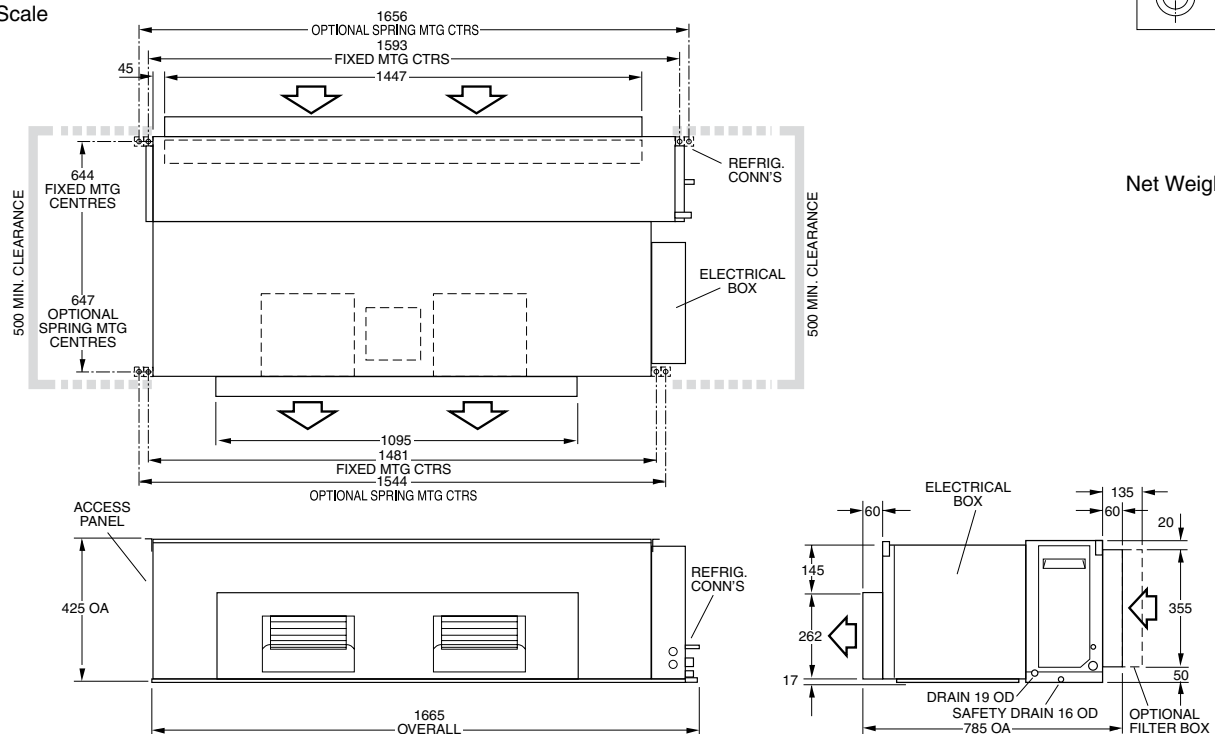

For long condensate pipe runs, fit a vent pipe near the drain trap. The top of the vent pipe must be at least 100 mm above the ISD unit's drain tray.

It is essential that the drainage system for the evaporator is checked by pouring water in the drain tray and seeing that it discharges at the end of the drain and does not overflow the drain tray.

Connect the safety drain tray drain pipe to a suitable drain line with an appropriate slope to allow free drainage. This drain line does not require trapping. Test the drain with water to ensure it clears safely.

## INDOOR-OUTDOOR UNIT

### CONNECTIONS

Refer to the relevant OSA Outdoor Unit 'Installation & Maintenance' pamphlet for piping instructions. For wiring connections, refer to the Outdoor Unit wiring diagram in conjunction with the ISD wiring diagram in this pamphlet.

### REFRIGERATION PIPING

#### Pipe Connection Sizes (mm OD) & Type

Liquid: 13 (1/2") sweat

Suction: 22 (7/8") sweat

The ISD is shipped from the factory with a pressurised holding charge of nitrogen. Immediately before removing any brazed pipe connection's seal, reduce the holding charge to atmospheric pressure.

**Warning:** Failure to do so may cause injury.

Refer to the Outdoor Unit 'Installation & Maintenance' pamphlet for evacuation procedure and piping requirements.

### ELECTRICAL WIRING

The electrical supply required (via the Outdoor Unit) is specified on the Outdoor Unit's wiring diagram.

Electrical work must be carried out by a qualified electrician in accordance with local supply authority regulations and the wiring diagram.

In a free blow or low resistance application, beware of exceeding the fan motor's full load amp limit (refer Outdoor Unit's wiring diagram).

**Note:** The SAT-2 Controller automatically switches the indoor fan off during de-ice, therefore no additional wiring is required to achieve this result.

### INDOOR FAN SPEED

The indoor fan speed can be 'Stepped' or 'Continuously Variable'. The choice is made using Switch 1 of 'DIP1' on the EC Motor Controller. Switches 1 to 5 on 'DIP2' determine the minimum and maximum fan speeds.

The same 'Minimum rpm' and 'Maximum rpm' settings apply to 'Stepped' and 'Continuously Variable'.

The default settings for DIP1 and DIP2 are highlighted on the Wiring Schematic.

#### 1. Stepped (DIP1 switch 1 = OFF)

Connecting the 24V AC power from the unit's 'HOT 24V' terminal to one (and only one at a time) of the 'LOW 24V' / 'MED 24V' / 'HIGH 24V' terminals, selects the 'LOW' (Min. rpm), 'HIGH' (Max. rpm), or 'MED' (mid-way between) fan speed. The transitions between speeds are smooth.

## Fig. 2 Separable (Option)

Separable for ease of installation through small man holes

– minimum 550 mm sq. clear aperture

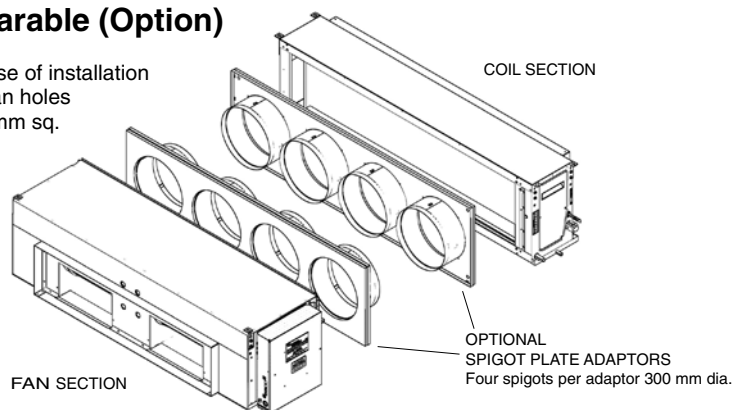

## Fig. 3 Spring Mounting



## Fig. 4 Solid Mounting

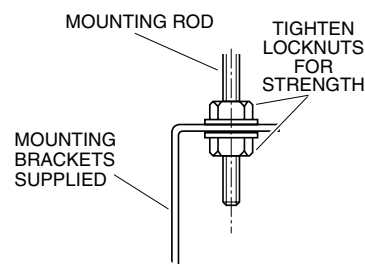

## Fig. 5

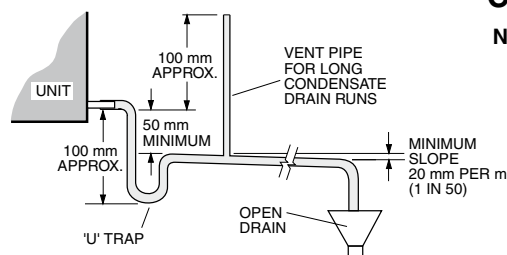

## Condensate Drain

**Note:** The Safety Drain Tray does not require trapping.

### 2. Continuously Variable (DIP1 switch 1=ON)

When using this method a temperzone Analog Signal Isolator (No. 201-000-129) must be fitted and connected as shown in the wiring schematic. 24V AC or DC power from the external (BMS) controller should be provided to the '24V' and '0V' input terminals of the Signal Isolator board.

A voltage below 2V DC applied across the '0V' and the '0-10V' input terminals (labelled 'From BMS Controller' in the wiring schematic) of the Signal Isolator will stop the indoor fan. A control voltage of slightly more than 2V will cause the fan to run at the 'Min. rpm' speed. A 10V DC signal will run the fan at the 'Max. rpm' speed. Control voltages between these two limits can be used to achieve any desired speed between 'Min.' and 'Max.' rpm.

**Do not use switch combinations marked with 'DO NOT USE' in the Speed Selection table.**

If the air returning to the indoor unit is regularly expected to be above 50%RH, then the coil face velocity should be limited to be 2.5 m/s or less (refer Air Handling graph in Technical Data pamphlet).

High humidity levels can occur in tropical or subtropical conditions, and/or when heavily moisture laden fresh air is introduced. Select a fan speed that avoids water carry-over problems.

### SAT-2 CONTROLLER

The following components are supplied in a box taped inside the return air spigot:

1. SAT-2 Wall Control plaque, including wall mounting plate.
2. 10 m interface lead (electrical box-to-plaque).
3. User's Operating Instructions booklet.
4. Lithium CR2032 battery (3V).

#### Optional

1. Remote return air sensor (in box).
2. Remote return air temperature sensor lead; 1.5, 6, 12 or 25 m.
3. 20 m extended interface lead (electrical box-to-plaque).
4. ISD indoor unit-to-OSA outdoor unit interconnecting lead; 12.5 m or 25 m; 7 core.
5. SAT-2 Zone Control PCB.
6. Zone Control 24V transformer.
7. Additional SAT-2 Wall Control plaque.
8. Infra red remote control.
9. Zone control leads to 24V dampers – 6 wire RJ-11 telephone type plugged cable (not supplied).

#### Installation

The SAT-2 Controller PCB is supplied pre-installed in the ISD unit's electrical box.

1. Isolate the ISD unit from power supply, then remove electrical box cover.
2. Remove the SAT-2 box supplied taped inside the return air spigot.

3. Remove the Wall Control's interface lead from this box and connect the bare wired end of the interface lead to the terminal block on the SAT-2 Controller board (refer wiring diagram). Trace the remaining length of the lead to the Wall Control's intended location.
4. Remove the Wall Control's backing plate by using a small screw driver to remove the single screw at the bottom edge of the plaque.
5. Install the Lithium battery, supplied loose, positive (+) side up in the Wall Control's battery holder.
6. Check the wall where the Wall Control plaque is to be located is flat before fastening the wall mounting plate. Alternatively, the mounting plate can be screwed to a standard wall socket mounted horizontally.  
**Note:** Use low profile (mush) headed screws to prevent contact with the PCB board. Fixing the plate to a distorted surface may damage the control.
7. Drill hole in wall to allow cable entry.
8. Connect the interface lead's lugs to the Wall Control board as per the wiring diagram overleaf.
9. Ensure the interface lead is run separately and away from main power supply wires, including the interconnecting cable. When installing cabling, trim any excess length to suit your location.
10. Fill around the interface lead with foam or cover hole with PVC tape to prevent draft from wall cavity affecting control operation. Do not use aluminium duct tape.
11. Secure the Wall Control body to the mounting plate by replacing the locking screw removed earlier.
12. Replace the ISD electrical box cover.

**Remote Air Temperature Sensor/s (option)**

The air temperature sensor is by default located in the Wall plaque. Optional remote air temperature sensors are available so that the measurement of the room temperature can be taken away from the wall plaque, eg. elsewhere in the room or in the return air duct.

Remote sensor's can be plugged directly into the Controller board (PCB). This board accepts up to four sensors which are designated as 'zones' one to four. The first return air sensor will automatically replace the Wall Control sensor and should be located in the same room as the Wall Control.

The Controller will always use the average of the zones selected. Refer to the separate installation instructions supplied with the PCB for further details.

Ensure all remote sensor wires are run separately and away from main power supply wires, including the interconnecting cable.

**Zone Control**

The ISD 235KY-DL includes zone control functionality via a plug'n play board in the electrical box, allowing up to 4 zone dampers to be switched from the SAT-2 wall control. Standard 24 volt damper motors can be used with drive open/drive close or drive open/spring closed. Connection leads required are 6 wire, terminated with RJ-11 connector plugs (not supplied). If using 230/240V dampers motors, contact **temperzone** first for wiring changes required.

**COMMISSIONING**

Indoor Unit

1. Check that the thermostat is correctly wired and set at the desired temperature.
2. Check that the air filter (if fitted) is clean.
3. Check that the fan runs freely without vibration.
4. Check condensate drain and safety drain tray for free drainage.

Refer to Outdoor Unit Installation Instructions in order to complete the start-up and commissioning procedure for the complete air conditioning system.

Demonstrate the SAT-2 Wall Control to the owner/user, after having first thoroughly familiarised yourself with the User's Operating Instructions. This page is to remain with the owner/user.

**MAINTENANCE**

**Weekly For First Four Weeks**

1. Check air filter (if fitted); vacuum clean as necessary.
2. Check condensate drain for free drainage.

**Monthly**

Check air filter (if fitted); vacuum clean as necessary.

**Six Monthly**

1. Check condensate drain and safety drain tray for free drainage.
2. Check heat exchanger coil; vacuum or brush clean as necessary.
3. Check the tightness of the fan.
4. Check that fan motor is free running.
5. Check tightness of electrical connections.
6. Check air supply at diffuser outlets.

**WARNING**

This unit is designed for use ONLY with the refrigerant HFC-410A (R410A). The use of other refrigerants is NOT authorised or approved by the manufacturer and may cause operational problems such as poor performance and efficiency, loss of capacity, degradation of materials and refrigerant leaks.

**The use of flammable or explosive materials as a refrigerant creates the additional risks of fire and explosion which may result in property damage, personal injury or death.**

**NOTE**

The manufacturer reserves the right to change specifications at any time without notice or obligation. Certified dimensions available on request.

**Fig. 7 Application Considerations**

**Recommendations for Noise Isolation**

- particularly for high static installations:

1. Avoid installing units, with non-ducted return air, directly above spaces where noise is critical.
2. Use flexible connections between unit and rigid ducting.
3. Use generously sized acoustically lined ducts.
4. If generous duct size is not possible, use turning vanes on bends to reduce air turbulence (regenerated noise).
5. Use 90° bends in ducting to significantly assist in noise reduction.

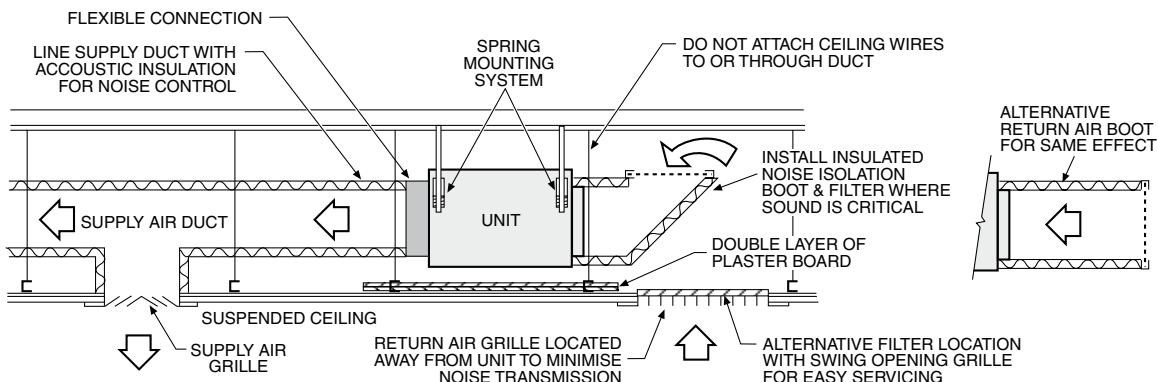
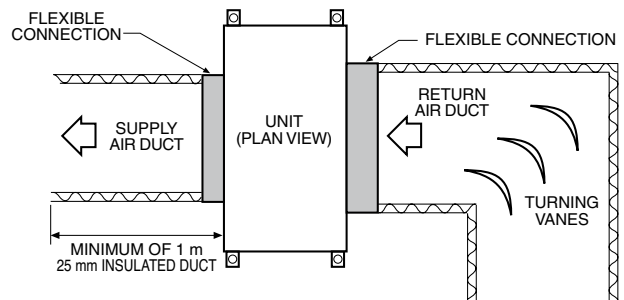

EC-Board speed selection - DIP Switch 2 (DIP2)

Switch 1	Off	Off	Off	Off	Off	Off	Off	Off	Off
Switch 2	Off	Off	On	Off	On	Off	On	Off	On
Switch 3	Off	Off	On	Off	On	Off	On	Off	On
Switch 4	Off	Off	On	Off	On	Off	On	Off	On
Switch 5	Off	Off	Off	Off	Off	Off	Off	Off	Off
Max (rpm)	1500	1400	1350	1300	1200	Do not Use	1100	Do not Use	Do not Use
Min (rpm)	1200	1000	1050	1000	900	Do not Use	800	Do not Use	Do not Use

Model	ISD 235KY-DL	
Voltage In	V	230/240
IFM (1.25KW)	Amps(MAX)	8 A

FRB	Fault Relay Board	MRC	Med Speed Relay
HR	Hi Speed Relay	MRC	Med Speed Relay Coil
HRC	Hi Speed Relay Coil	SDR	Shut Down Relay
IFM	Indoor Fan Motor	SDRC	Shut Down Relay Coil
LR	Low Speed Relay	TR	Transformer
LRC	Low Speed Relay		

SAT 2 Board definitions	
OUT1	4-Way Valve
OUT2	Heater
OUT3	Comp 2
OUT4	Drain/Pump
OUT5	Power In
OUT6	Zone/Motor
ALARM OUT	Fault Relay
RELAY1	Zone Control Board
COM	Common
D16	HP Switch
D15	LP Switch
D14	Float Switch
D13	Hydronic Pump
D12	No Function
D11	SD
AD8	Discharge 2
AD7	Discharge 1
AD6	Return Air 4
AD5	Return air 3/Indoor Coil 2
AD4	Return Air 2/LST
AD3	Return Air 1
AD2	LST 1
AD1	Indoor Coil 1
SEC	Transformer Secondary
PRI	Transformer Primary

Standard setting	Off	On
1	3 Speed fan Hi/Med/Low	On
2	Normal forward Action	Reverse action
3	1.25KW Motor	900W Motor
4	Leave in this position	Do not use

Standard setting	Off	On
1	Cool only	Heat pump
2	No electric heaters	Electric heaters fitted
3	1.5°C Differential control	1.0°C Differential control
4	Fan on in cool cycle (dead band recommended) for in-duct sensors	Fan off in cool cycle
5	Air cooled	Hydronic
6	Two Stage	Single stage
7	Fault relay activated upon final lock out	Fault relay activated With each system fault
8	Fan on in heat cycle (dead band recommended) for in-duct sensors	Fan off in heat cycle (dead band)

Title ISD 235KY-DL Wiring Schematic (c/w t/stat SAT-2 & Zone Plug n Play Kit)



Drawn S.D.H.	Date	21-07-12	Drawing No.	Revision
Aprv	KZ	P.C.L	291-000-194	---

Plotted	25-07-12	©temperzone ltd 2012
Visit	www.temperzone.biz for client wiring diagrams	
Client wiring	ECN	DATE
ISSUE	MODIFICATION	APRVD

