

# OSA 670RKTBV

## Reverse Cycle R410A Split System Outdoor Unit

## Installation & Maintenance

### GENERAL

The OSA 670RKTBV outdoor unit is a twin system that provides the facility for capacity control (staging) or staggered starting.

This OSA 670RKTBV outdoor unit, with matching ISD 670KB indoor unit, must be installed in accordance with all national and local safety codes.

Refer to **temperzone** Engineering for installation of any other outdoor/indoor unit combinations.

### Options

1. TZT-100 Room Temperature Controller
2. UC6 Service Interface tool.

### INSTALLATION

#### Positioning

Refer to dimension diagram below for minimum clearances. Fasten the unit down to a firm flat horizontal base using the holes provided in the mounting rails.

When the unit is being installed on a roof it is recommended that the unit is installed on a substantial structure with anti-vibration mounts or pads.

#### Drain

Four drain holes are provided in the base of the unit to release condensate and/or rain water.

### REFRIGERATION PIPING

#### General

The OSA 670 is shipped with a refrigerant charge sufficient for a 10 m line length. The matched indoor unit is shipped with a holding charge of nitrogen. OSA 670 units have brazed pipe connections.

#### Recommended Pipe Sizes

Suction pipe (x2): 28 mm OD  
Liquid pipe (x2): 13 mm OD

#### Line Lengths

The standard unit is suitable for a line length up to 60 m. For line lengths between 60 m and 90 m, refer to **temperzone's Split Systems Installation Guide** (refer [www.temperzone.biz/Technical Support](http://www.temperzone.biz/Technical Support)). Refer also to *Oil Charge* overleaf.

Maximum line length when extended is 90m.

#### Height Separation Limits

Outdoor Unit above Indoor Unit : 20 m  
Outdoor Unit below Indoor Unit : 20 m

#### Vertical Risers

If the outdoor unit is to be installed above the indoor unit, then the suction riser should be trapped at the bottom of the vertical rise and then again at 8 m (maximum) intervals. This is to ensure oil return to the compressor. The trap to be a 'swan neck' curve in the pipe, with no change in the pipe size.

#### Piping

1. Use clean sealed refrigeration grade piping and accessories designed specifically for R410A.
  2. Cut pipe with a pipe cutter ONLY.
  3. Use long radius bends (2x pipe dia.).
  4. Insulate the suction (gas) line and seal all insulation joints.
  5. Bi-flow type filter dryer may be fitted in the liquid line.
  6. Include a process point on the interconnecting pipework.
  7. Ensure open pipe ends are sealed until the final connection is made.
  8. Immediately before removing brazed pipe connection's seal, reduce holding charge between connection points and service valves to atmospheric pressure.
- Warning:** Failure to do so may cause injury.

#### Important

Do not connect System 1 to System 2.

#### Charging

The unit is supplied with sufficient refrigerant HFC-410A (R410A) for 10 m of pipework between the indoor and outdoor units; refer wiring diagram specification table for

### Dimensions (mm)

### OSA 670RKTBV

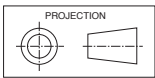

Not to Scale

Net Weight 541 kg

CORNER LOADS (kg)				
W	X	Y	Z	
182	88	88	183	

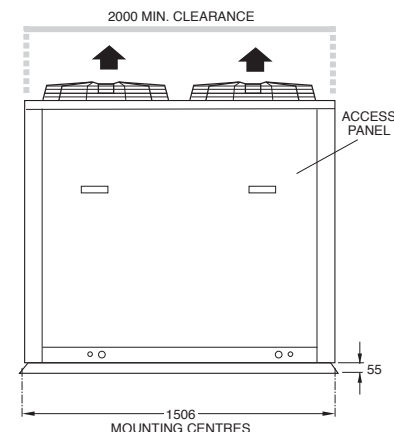
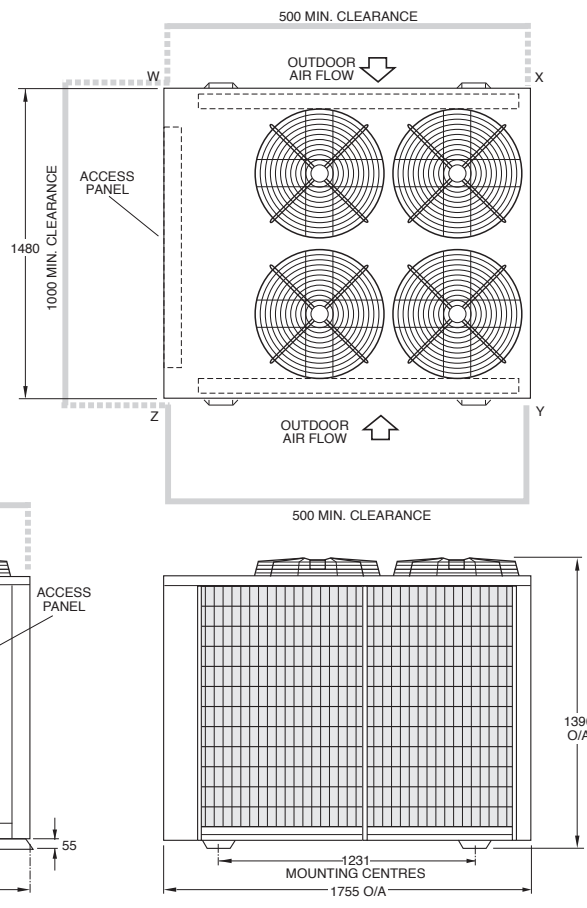

amount. Add 100 g per metre per system above 10 m.

**Procedure (per system):**

1. Evacuate Indoor Unit and interconnecting pipework to a pressure of 500 microns and hold for 15 mins.
2. Add refrigerant via the Schraeder connection on the smaller of the Outdoor Unit's two service valve extension pipes.
3. Open the service valve at the Outdoor Unit to allow refrigerant to flow throughout the system.
4. Leak check all brazed and fitted joints.

**IMPORTANT :**

Step 7 of the 'Start Up Procedure' requires you to check that the superheat on the suction line (where it enters the Outdoor Unit) is between 3°C – 5°C on cooling cycle with an indoor air temperature in the range 21° – 27°C and outdoor air temperature in the range 24° – 35°C. If the conditions of the day do not allow this, use the heating cycle (on a reverse cycle unit) or other heat source to raise the indoor air temperature to about 24°C and blank off the outdoor coil to raise the head pressure to 400 psig (2760 kPag). Alter charge up or down to establish correct superheat.

**WARNING:**

This unit is designed for use ONLY with the refrigerant HFC-410A (R410A). The use of other refrigerants is NOT authorised or approved by the manufacturer and may cause operational problems such as poor performance and efficiency, loss of capacity, degradation of materials and refrigerant leaks. **The use of flammable or explosive materials as a refrigerant creates the additional risks of fire and explosion which may result in property damage, personal injury or death.**

**Oil Charge**

For line lengths in excess of 30 m, Emkarate RL22CF polyolester oil (or similar) should be added to the refrigerant at the rate of 30 ml/m of suction piping.

**Note:** This oil absorbs moisture quickly if exposed to open air. Do not use mineral oil.

**ELECTRICAL REQUIREMENTS**

Electrical work must be done by a qualified electrician. The outdoor unit must be wired directly from a distribution board by means of a circuit breaker or H.R.C. fuse, and a mains isolator provided - preferably close to the Outdoor Unit.

**Note:** DO NOT USE REWIRABLE FUSES.

The OSA 670 is provided with a 24V AC control circuit for a thermostat, on/off switch and/or time clock.

Standard units are suitable for use with thermostats with either manual Heat/Cool selection or automatic changeover subject to the contact ratings of the thermostats.

Refer to **temperzone** for recommended thermostats.

A 24 hour power supply to the crankcase heaters is required, via the UC6 Controller, otherwise the warranty is void.

**SYSTEM CHECK TESTS**

1. Check by hand that all fan motors can turn freely.
2. Check the tightness of all electrical connections and sign the check label.
3. Leave the room temp. thermostat in the off position and close the mains isolating switch. (A four hour delay period is required to allow the crankcase heater to drive any liquid refrigerant out of the compressor oil.)
4. Check the supply voltage between each phase and neutral.
5. Check that the thermostat is correctly wired to the unit and is set at the desired temperature.
6. Check that the air filters, if any, have been correctly installed.
7. Check any supply air diffuser dampers are open.

**START UP PROCEDURE**

Check each system independently first before running complete system. After the four hour delay for the crankcase heater has expired, use the supplied Commissioning Sheet to record results when completing the following 'Start-up' procedure. Ideally a *UC6 Service Interface* and associated communication cable (temperzone part no.s 201-000-379 and 201-000-378) should be used to read, pressures, superheat and its set-point, compressor amps etc.

1. Select a sensible Fan speed (or Auto Fan mode), operating cycle (cool or heat), and room temperature set point, depending on the time of year, such that the compressor will start and run at a high capacity.
2. Turn ON the thermostat / External controller. Wait for the compressor to start and reach a stable speed. Measure the current for each phase feeding into the compressor's. Compare against the compressor amps specified on the unit's wiring diagram.
3. Check for correct rotation of the compressor. If rotation is incorrect the compressor will not pump and will draw minimal current. To correct motor rotation, change the phasing at the main power terminal.
4. Measure the current draw of each fan motor. Check all readings against the specified values in the wiring diagram.
5. If a *UC6 Service Interface* is available, operating pressures and status can be read from its various display screens. If a *UC6 Service Interface* is not available, fit gauges and measure the suction and discharge pressures of both refrigeration circuits. **Important:** Gauges must be designed specifically for use with R410A.
6. Check that the outdoor air fan motors are running smoothly and drawing less than the full load amps specified.

7. Check the superheat - refer charging procedure.
8. Check the indoor unit's fan belt tension after 20 mins of operation and adjust if necessary (refer Commissioning Sheet).
9. Test the operation of the reversing valve by running the unit in both the heating and cooling mode.
10. Check the supply air flow at each outlet.
11. Touch up any outdoor unit paintwork damage to prevent corrosion.

**SETTING SUPPLY AIR FLOW**

Consult ISD/OSA 670 Technical Data pamphlet at [www.temperzone.biz](http://www.temperzone.biz) for details of airflow/duct static pressure, if required.

If the indoor air returning to the unit is regularly expected to be above 50%RH, then the coil face velocity should be limited to be 2.5 m/s or less (refer Air Handling graph in Technical Data pamphlet) to avoid water carry-over problems.

**UNIT CONTROLLER (UC6)**

The Unit Controller provides system protection functions such as coil frost protection, de-icing, high head pressure and low suction pressure cut-out. It also protects against rapid cycling of the compressor and loss of refrigerant. Various methods of head pressure control (or limiting) are employed in temperzone units. The particular method used varies from model to model, but is handled by the Unit Controller. In combination, these features deliver optimised performance across a wide operating temperature range.

Refer to UC6 Controller label on the unit for operation & fault diagnostics information. Many operating status conditions can be determined, without gauges, simply by using a *UC6 Service Interface* graphical display available from **temperzone**.

**MAINTENANCE**

**Weekly For First Four Weeks**

1. Check air filters, if fitted, and vacuum or wash clean as necessary.
2. Check condensate drain for free drainage.
3. Check compressor compartment for oil stains indicating refrigerant leaks.

**Three Monthly (or every 1200 hrs of operation)**

Check the indoor unit's fan belt tension and adjust if necessary.

cont'd...

**Pipe Length Capacity Loss**

**On Cooling Cycle Due to Pressure Drop**

**Note :** Loss percentages are approximations only, due to piping variations. No allowance made for vertical piping.

Pipe Size (mm)		Performance Loss per additional 10m beyond first 5m.	Additional Pipe Length to allow per Bend		
Liquid	Suction		Suction Pipe Size OD		
13 (x2)	28 (x2)	1.5 %	28 mm	35 mm	
13 (x2)	35 (x2)	0.7 %	Long 90° Radius (i.e. 2 x pipe dia.)		0.76 m

## MAINTENANCE (cont'd)

### Six Monthly

1. Check the tightness of electrical connections.
2. Check the tightness of fans and motor mountings.
3. Check suction and discharge operating pressures. (Using a *UC6 Service Interface* avoids fitting and removing gauges with consequential refrigerant loss.)
4. Replace indoor unit air filters (if fitted).
5. Check condensate drain for free drainage.

### Yearly

1. Check all refrigerant piping for chafing and vibration.
2. Check air supply at all diffusers.
3. Check for excessive noise and vibration and correct as necessary.
4. Check for insulation and duct damage and repair as necessary.
5. Check and remove as necessary any lint and dust accumulation from outdoor coil fins. In corrosive environments, the checking and cleaning frequency should be increased.
6. Touch up all outdoor unit paintwork damage to prevent corrosion.

### NOTE

The manufacturer reserves the right to change specifications at any time without notice or obligation. Certified dimensions available on request.

This pamphlet replaces the previous issue no. 6824a dated 09/18.  
Wiring rev. I.

