

AIR CONDITIONERS

*for surgical rooms,
hospital facilities
and clean rooms*

H Series



TECNAIR LV
SURGICAL ROOM AIR CONDITIONING





TECNAIR LV
CLOSE CONTROL AIR CONDITIONERS

 **LU-VE**
GROUP
leadership with passion 

Air conditioners for surgical rooms, hospital facilities and clean rooms

- With direct expansion coil: **series OHA**
- With chilled water coil: **series OHU**
- With direct expansion coil and hydronic heat recovery: **series OHA HR**
- With chilled water coil and hydronic heat recovery: **series OHU HR**
- With chilled water coil and direct expansion post-cooling: **series OHU PC**
- With chilled water coil, hydronic heat recovery and direct expansion post-cooling: **series OHU HR PC**

Contents

- Essential features	pag. 5
- Construction characteristics	pag. 14
- Regulation	pag. 18
- Microprocessor and software	pag. 22
- Operational safety	pag. 24
- Version with direct expansion post-cooling circuits	pag. 26
- Energy saving	pag. 28
- One machine for each room	pag. 30
- One machine for multiple rooms	pag. 32
- Plant for diagnostic imaging	pag. 34
- Accessories	pag. 40
- Operating performance	pag. 42



We confirm to the company

**TECNAIR LB
I-21040 Uboldo**

because of the positive results of the tests of the
series OH

that the requirements of the Certification Program of the
TÜV Süddeutschland Bau und Betrieb GmbH are fulfilled.

The manufacturer is allowed to use the following sign:



Munich, 15th of October 2001

Kälte- und Klimatechnik

Testofficer

ZERTIFIKAT ◆ CERTIFICATE ◆ 證書 ◆ EPPIITAT ◆ CERTIFICADO ◆ CERTIFICAT

Hyg

Essential features

General information

- For the treatment of full fresh air or with partial recirculation.
- Available static pressure selectable from 250 to 1,000 Pa depending on the type of plant and the need to install absolute filters after the unit.
- Section for air suction from the rooms, partial recycle or total exhaust to the outside.
- Static or dynamic management of overpressure or depression in the controlled room compared to a reference environment.

The units are equipped with controls,

electrical panel, microprocessor and dedicated software. They can be expressly customized for:

- General surgery rooms
- Orthopaedic surgery rooms
- Very low-temperature heart surgery rooms
- Intensive care units
- Sterilization rooms
- Diagnostic imaging rooms
- BSL laboratories for the treatment of viruses or substances which are toxic, radioactive, nuclear, flammable or contaminating in general
- Hospital wards
- Dental surgeries
- Biotechnology laboratories
- Anatomical pathology laboratories
- Mortuary chambers.



GOST certification





For more than ten years Tecnaïr LV SpA has been the European leader for the design and construction of specialized air conditioners for surgical rooms. Its **“H” Series**, equipped with controls, microprocessor and software, has been revised so that it can also be used in other specially delicate applications with different characteristics such as diagnostic imaging rooms, intensive care units, wards etc.

In fact, in these applications where there is neither open wound nor high-level environmental contamination, absolute filters are not necessary either at air supply or suction, and therefore neither is high static pressure for the supply fan and the suction/exhaust fan.

The standard version of the new **“H” Series** air conditioners for surgical rooms, hospital facilities and clean rooms has low static pressure of approximately 250-300 Pa on both the supply and suction fans. High performance fans can be provided as accessories: up to 1,000 Pa, with epoxy painting of the fins in order to satisfy even the most critical applications.

In practice, the *entry level* unit (which is in any case dimensioned to treat full or almost full fresh

air) is suitable for diagnostic imaging rooms or hospital wards. With the appropriate options added, the unit can be configured to fulfil the requirements of the most demanding plant design conditions such as those for surgical rooms where highly specialized operations are to be performed.

TUV Certification Compliance with Standard DIN 1946/4

The **“H” Series** air conditioners, configured with the accessories mentioned above, conform to the German Standard DIN 1946 part 4. They are certified to be in compliance by TUV.



Version with chilled water coil: OHU

Uses the water supplied from a remote chiller as the source of cooling. Equipped with a three-way regulation valve as standard (two-way accessory) controlled by microprocessor.

Version with direct expansion circuit: OHA

The “**H**” **Series** air conditioners with direct expansion coil are equipped with one or two independent cooling circuits. Low noise, high-efficiency, scroll-type compressors are used. The standard expansion valve is electronic and can therefore guarantee maximum control of the temperature with minimum energy consumption and effective antifreeze control of the evaporating coil.

The cooling circuits have all the components necessary for regulation, protection and safety. They are positioned, together with the electrical panel and all the controls, in a technical compartment on the right side, out of the treated

airflow. They use the ecological refrigerant R410A which is completely harmless to the ozone layer and has a very low impact on the environment. The OHA models to be matched with remote condensers are supplied with a nitrogen pressurization charge. The final charge together with any oil top-up is done by the installer on-site. The refrigerant and oil charges are done in our factory if the water cooled condenser (accessory) is incorporated.

Easy hygienization and sterilization

All the internal components of the “**H**” **Series** air conditioners which are in direct contact with the airflow can easily be rendered hygienic as they can be reached and extracted by simply opening the access doors.

The entire machine is made accessible in this way. This means that maintenance and cleaning operations can be carried out correctly as scheduled, easily and quickly.



No risk of Legionella Pneumophila

During the design and construction of the “H” Series air conditioners, all possible measures have been taken to exclude any chance of the formation of Legionella Pneumophila bacterial colonies inside the unit. Very high-level interior conditions of hygiene are ensured by the materials used, the easy cleaning of the most at-risk components, and the units’ operating ranges.

High quantity constant fresh air flow

Chemical contamination, present in particular in surgical rooms, cannot be filtered out but must be diluted with large quantities of constant fresh air flow. The management of the airflow is entrusted, via a microprocessor, to an inverter which controls the rotation speed of the air supply fan depending on the air flow setting and

the degree of clogging of the machine’s own filters and other filters external to it. The desired air flow is directly selectable by the user and can vary from a minimum to a maximum value according to the model of the air conditioner.

Very high air filtration

To prevent airborne bacterial contamination of the room, the fresh air flow is passed through, in compliance with the applicable Regulations, standard G4 efficiency filters at the air intake of the machine (F7 as an accessory) and through F7 standard post-filters (F9 as an accessory) after the fan at the entrance of the air supply ducts. An M5 filter is also provided at the entrance of the suction air duct before the exhaust fan in order to keep the interior of the machine clean. The standard unit supplies approximately 250/300 Pa and can reach the 800/1,000 Pa static pressure (accessory) necessary for the essential sound damper and any terminal absolute filter. If this filter is



present, it has to be installed directly in the room to be controlled as any other aeraulic element after it may contaminate the air flow. Selecting high static pressure exhaust fans also allows the installation of an absolute filter at the inlet of the re-suction air ducts before the sound damper; this, together with the management of the depression in the room, is necessary in order to avoid polluting the external environment if toxic substances are to be treated or septic operations carried out.

Indoor or outdoor installation

The air conditioners have been designed for both indoor and outdoor (accessory) installation. Their extreme compactness, reduced noise level and pleasing appearance all make them suitable for installation near the rooms to be conditioned, thus avoiding lengthy expensive duct work. External installation however requires the air conditioners to be positioned under a protective canopy to ensure comfortable access

when maintenance has to be performed during bad weather.

Easy installation

The machine has been designed to be easy to install. Once positioned where it is to be installed, it only needs electrical, hydraulic, cooling, ducting and remote accessory connections. The relevant manual gives all the necessary procedures for the perfect installation, subsequent checking and final testing of the equipment.

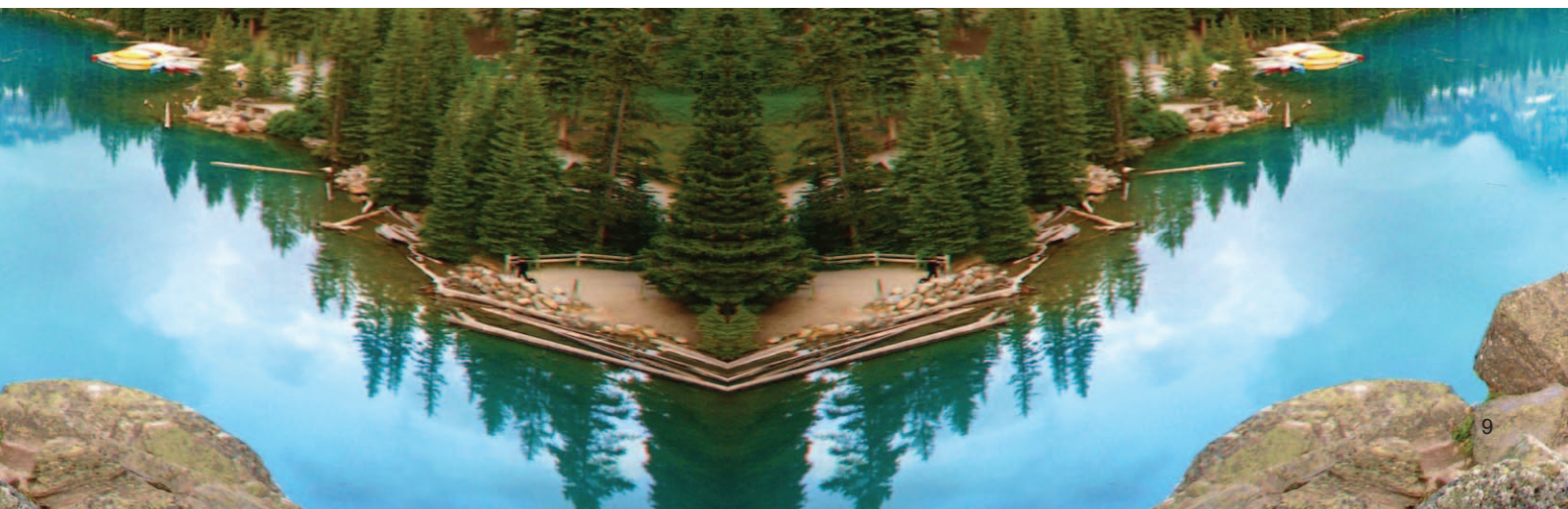

OHU 2200



serie H

OHU 2200



OHU 2200 HR



serie H

OHU 2200 HR

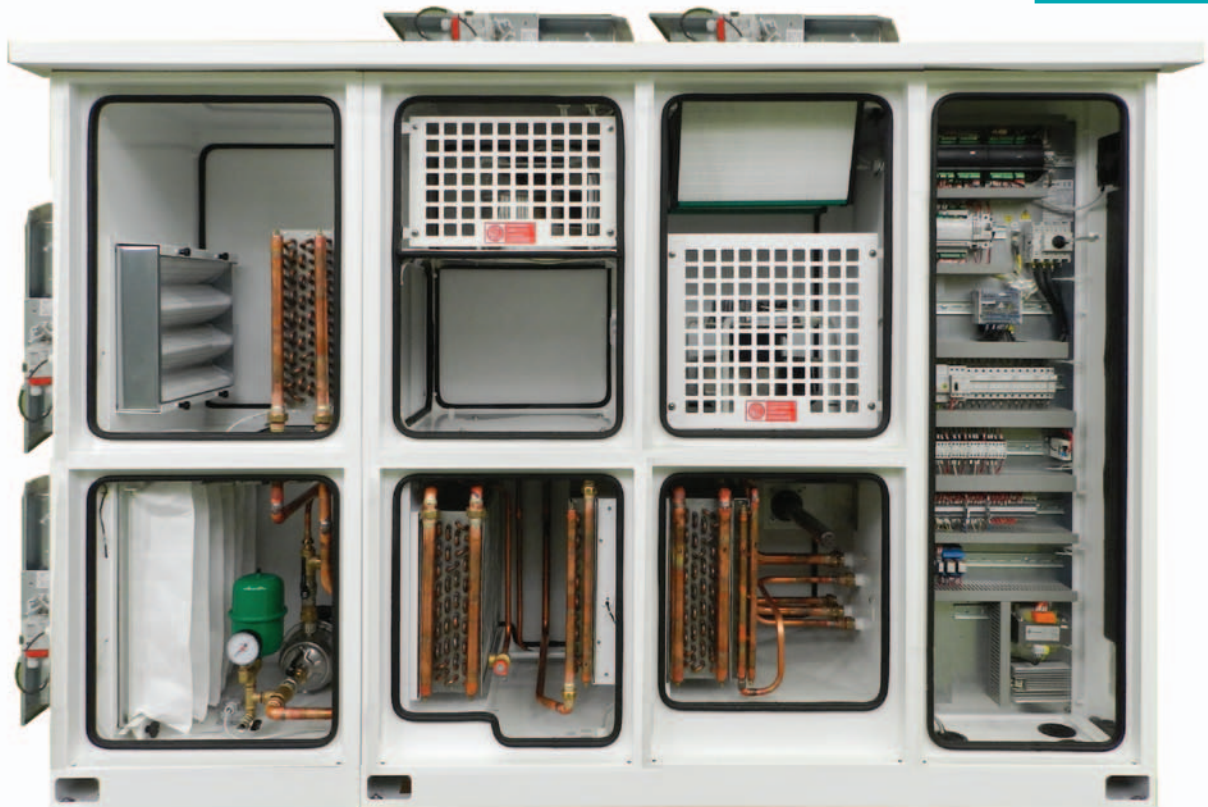

Construction characteristics

Structure of the unit

The structure is made of welded metal plates which are surface treated with epoxy-resin paint (60 microns, white) after cathaphoresis. The panels are double-skinned, 50mm-thick sheet steel. They are painted white as above and have an internal sandwich layer of heat and sound insulation in rock wool (fire resistance class 0). The internal panel can be supplied in stainless steel if requested as an accessory. The supply and exhaust air outlets are upper, vertical, in the standard version; they can as a variation be rear, horizontal. In this case, the air supply filter is installed in the appropriate canister provided, to be installed on site on the outside of the unit. The front panels have inspection portholes positioned so that the interior of the machine can be checked without opening and therefore stopping it. It should be remembered that in some cases such as

surgical rooms, these machines must operate continuously so that they do not lose their overpressure and compromise the air quality. The panels can be opened by keys for access and maintenance and the closing mechanisms can also be padlocked for greater safety. The panels have elastomer seals which do not react with sterilizing agents.

Air supply fan section

This section has either one or two plug fans with electronic speed control to guarantee constant airflow even if the filters become increasingly clogged, increasing their pressure drop. Double fans can also be provided as an accessory for use in emergency.



Return and exhaust fan section

Also this section has either one or two inverter-controlled plug fans to guarantee the required level of overpressure or depression in the area to be controlled. The standard external static pressure of the suction/exhaust fans is approximately 250 Pa. Fans with much higher static pressure can be installed (accessory) in order to manage, for example, external absolute filters: infectious departments etc. Double fans, with double inverters, can also be provided for use in emergency.

Version without exhaust fan section

A version without the return and exhaust fan section (accessory) is available for installations where the quantity of fresh air is limited to that necessary for the pressurisation of the room, without any provision for exhaust.

Motorised dampers on fresh air inlet and gravitational dampers on the exhaust outlet

To prevent the wind from blowing pollution into the machine during shutdown.

Motorised dampers on all vents

Motorised dampers (as accessories) can be fitted to the vents going to and coming from the controlled room. In this case the standard gravitational supply damper is substituted with a motorised version.

Airtight motorised dampers on all vents

As above, but airtight and certified Class 4 by TÜV in compliance with Standard DIN EN 1751.



Motorised recirculation damper

For partial recirculation installations, a motorised by-pass modulated damper (accessory) is available counter-opposed to the fresh air one. This saves a considerable amount of energy and reduces running costs significantly. When the recirculation damper is fitted, the fresh air filter is substituted with other pleated filters of efficiency standard G4 or F7 (accessory) in order to improve the size of the section for mixing with the fresh air.

Differential pressure sensor for each filter

Each filtering section of the machine is equipped with a differential pressure sensor which can be set to signal the level of filter clogging via microprocessor. As an alternative, pressure sensors can be supplied which not only signal the alarm via microprocessor but also provide

an analogue indication of the level of clogging. In this case, the pressure sensors are located on the outside of the electrical panel.

Immersed-electrode humidifier

The standard humidification system is the immersed-electrode type. A characteristic of these humidifiers is the proportional production of steam between 10% and 100% of their capacity. The capacity of the humidifier can be selected depending on the quantity and condition of the fresh air.

Immersed-resistance humidifier

This accessory can guarantee excellent performance even when using water which is low in mineral salts, is demineralized or is generally of poor quality.



Centralised steam system regulation and distribution

If the Hospital has a centralised steam distribution system at a pressure of 1 bar (relative), a stainless steel steam controller and distributor can be installed as an option. This system allows modulation of the steam supply from 0% to 100%.



Condensate supply and siphons

All the air conditioners (both direct expansion and chilled water type) need their condensate and humidifier drainage systems to be connected to the building's waste system. The siphon, which is essential for the supply of condensate from the relevant drip tray because it is positioned in a depression point, is supplied ready-fitted inside the unit.

Regulation

Temperature and humidity sensors

The control of the unit is based on the information from the temperature and humidity sensors. In the standard machines, these are installed in the air suction and exhaust sections. Alternatively, TECNAIR LV can install the temperature sensor in the supply fan compartment and the humidity one in the re-suction compartment. The sensors can also be supplied loose, unfitted, so that the customer can install them in the controlled room or in the re-suction ducts. Each different solution is best suited to a particular type of system. The advantages and disadvantages of each solution are specified in the unit installation instruction manual.

Static control of overpressure or depression

This is to prevent any kind of contamination entering or leaving the designated space. The static control of overpressure or depression (standard) is carried out by respectively reducing or increasing the re-suction fan airflow using manual settings of the electronic control of the fan. This regulation, which is perfectly adequate for hospital wards for example, is not sufficient for areas with higher air quality requirements such as surgical rooms or infectious wards.



Dynamic control of overpressure or depression

(Accessory) A crucial and sophisticated characteristic of the “H” series air conditioners is its ability to automatically control two different operating ranges of overpressure or depression of the room compared to the surrounding areas. Via the provided differential pressure sensor to be installed between the controlled room and a nearby area, and thanks to the electronically controlled exhaust fan, the microprocessor can control:

- **overpressure**, by reducing the exhaust airflow compared to that introduced, which must remain constant. This makes it impossible for

airborne particles and pathogens to enter the room from the surrounding areas. If doors are kept open, the microprocessor reduces the exhaust airflow to create an air current which has to exit through the door, thus preventing the entrance of any type of particle.

- **Depression**, by increasing the exhaust airflow compared to that introduced. This prevents pathogens or toxic substances escaping to the outside areas. Obviously, a room in depression is not protected from the infiltration of contaminants, so it has to be perfectly sealed and connected to the outside through an overpressure filter zone with an interlocking door system. The filter zone can be supplied by the same air conditioner.

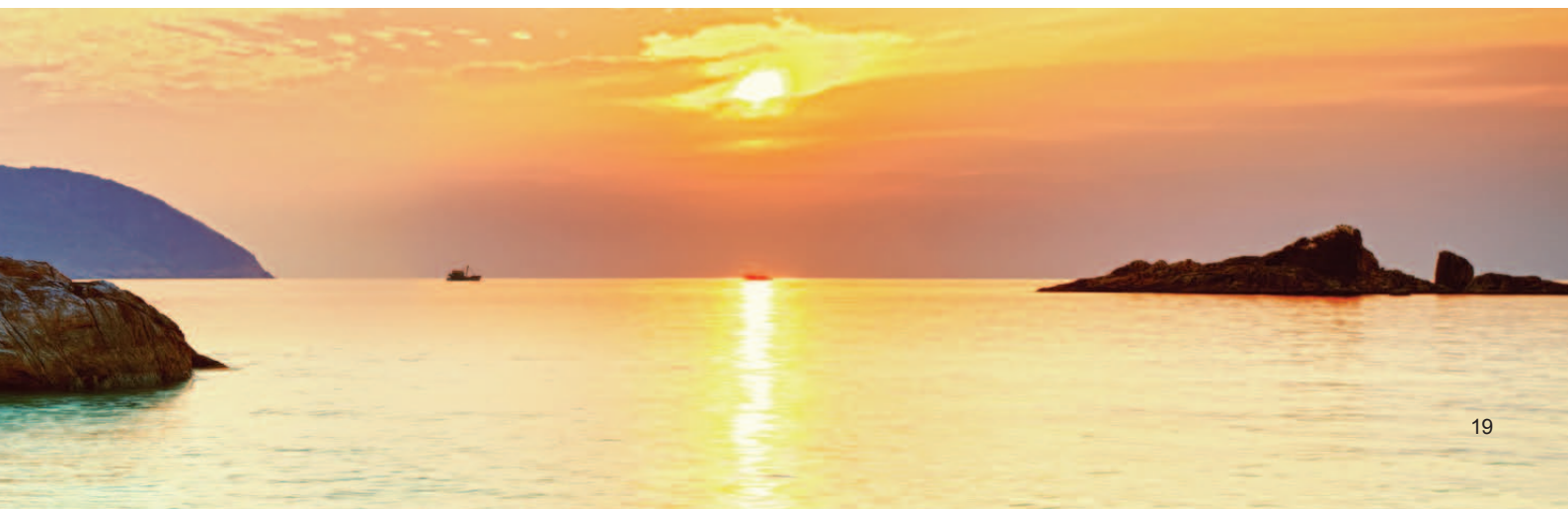

Management of constant pressure airflow in the supply duct

If a single unit has to supply more than one room (see design), the control of constant pressure airflow in the supply ducting is essential (accessory). To do this, Tecnaïr LV installs a differential pressure sensor on the air outlet vent of the machine. It monitors the internal pressure of the supply duct and communicates this data to the microprocessor which compares it to the set point and accordingly changes the fan speed in order to bring the supply airflow back to the required level.

Pressure sensor to read the airflow with constant pressure control

If constant pressure regulation in the supply ducts is selected, a pressure sensor is available as an accessory which permits the real-time

reading of the concurrent airflow. The accessory simplifies the regulation of the machine during start-up and maintenance.

Constant depression control in the suction ducts

(Accessory). In units with constant pressure control in the supply ducts, the room pressure also has to be controlled to maintain constant pressure inside the suction ducts. Motorized VAV boxes in the suction ducts to control overpressure and post-heating coils (supply not included) must be installed, one for each controlled room. This system is indispensable if a single machine has to supply more than one room and manage overpressure or depression, one independently of the other.



Integrated temperature and humidity control

The standard machines are equipped with all the components necessary to regulate cooling, heating, humidification and dehumidification. These components are sized for the treatment of full fresh air or with partial air recirculation, and in particular:

- Hot water heating coil with modulating control valve.
- Chilled water cooling coil with modulating valve, OHU Series, or as an alternative.
- Direct expansion coil with cooling circuit, OHA Series.
- Post-heating coil: hot water coil with three-way modulating valve for machines with chilled water cooling coils; electric modulating as an accessory. Electric modulating coil as standard for direct expansion machines.
- Independent modulating immersed-electrode humidifier, immersed-resistance or as an alternative.
- Modulating centralized steam distribution system.

Modulating regulation of the cooling capacity: OHU

(for machines with chilled water coil)

The three-way valve (two way as accessory), controlled by microprocessor, allows perfect modulating regulation of both cooling and dehumidification.

Modulating regulation of the cooling capacity: OHA

(for machines with cooling circuit)

The standard electronic expansion valve guarantees reasonable control of the cooling capacity. If the required temperature tolerance is very tight, or if a lot of, or indeed full, fresh air is treated, the accessory to control the cooling capacity of the compressor can be installed. This is able to modulate the capacity between 100% and 10% of the nominal capacity of the circuit.



Microprocessor and software

All operating and safety functions of the “H” Series air conditioners are managed by the standard microprocessor. This allows the temperature and relative humidity to be controlled in three ways: proportionally, proportional-integrally or proportional-integral-derivatively. PID activation is assisted by an auto-tuning programme. The control of relative humidity is proportional. The microprocessor also controls overpressure and depression and can be easily connected to the BMS of all the major constructors.

Serial communication and supervision system: BMS

With the development of BMS (*Building Management System*), the problem of communication between the control systems of different companies becomes ever more frequent. Today in fact, it is not only the quality and reliability of the instruments that is important, but also the degree of external connectability that they can offer.

This is why the controls used by TECNAIR LV today can:

- Be integrated into a system consisting of instruments from different constructors which share information via the integrated RS485 Modbus card and a gateway specifically designed for BACnet and LonWorks (accessories).

- Be managed remotely through a specific gateway (accessory), via modem and internet using a simple browser.
- Inform authorised personnel wherever they are of any alarm situations through a specific gateway (accessory), also by SMS.

User interface terminal

The powerful microprocessor of the system that manages and regulates the unit allows a remote terminal to be installed (as an accessory). This is identical to that fitted to the machine and is for installation in the control room. This terminal enables the direct detection from the room of the operational state of the unit and modification of the temperature and humidity set points. There is also an integrated function which displays trend graphics of the ambient temperature and humidity for the current day and the previous seven days.



Emergency activation system of room depression

Can be activated through a digital port. Enables the ambient pressure setting to be forced immediately in order to obtain depression compared to the surrounding rooms and so avoid any infective agents being spread if they are detected during normal operations.

Operational safety

The “H” Series air conditioners have been designed, from both the mechanical and software points of view, to guarantee maximum operational reliability and therefore to avoid any risk of suspending a surgical operation in progress.

Complete electrical panel

The electrical board is equipped with a door-locking main switch and all the components necessary for the protection and normal operation of the unit.

There are terminals for the remote connection of a cumulative alarm signal and others for the remote control of start-up and stop functions.

Double fan

The machine can be fitted with a second fan for supply air and a second fan for return air and exhaust (accessory) to function in emergency. This solution guarantees that the machine can continue to run in complete safety even if one of the two fans breaks down. Both fans are intercepted by a damper fitted upstream of

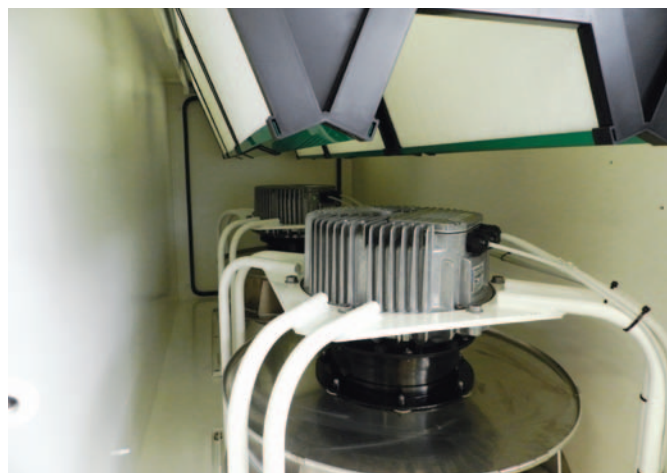

them to prevent recirculation if only one of them is in operation. The two fans are controlled by microprocessor via the electronic regulation of their rotation speed, based on the measurement of the internal airflow of the unit. They provide the total nominal airflow of the machine. If one of the fans breaks down, the microprocessor registers the reduced airflow and increases the speed of the other to guarantee the maximum airflow compatible with one-fan operation, in any case equal or very close to the nominal value.

Uninterruptible power supply: UPS

Two terminals are available on the electrical panel to be connected to a clean contact of the continuity group or generator so that, if the voltage is interrupted, the microprocessor stops the operation of components which are not indispensable such as compressors, humidifiers and electrical coils, leaving in operation only the supply fans, the suction and exhaust fan and the regulation.

Antifreeze system

This system guarantees active protection from the risk of freezing thanks to the presence of a relative temperature sensor, installed downstream of the pre-heating coil and upstream of the cooling one. If the antifreeze sensor detects a temperature below that of a pre-set value, it activates emergency intervention by opening the heating 100%. If after a set amount of time the temperature is still under the alarm level, the fresh air damper is closed and fans are switched off. The anomaly is displayed on the main mask of the microprocessor. The fans start again as soon as the temperature returns above the pre-set value.



Version with direct expansion post-cooling circuits

For very low temperature rooms: heart surgery

For some specialized operation procedures, in particular for heart surgery with extracorporeal blood circulation, ambient conditions are required to be at 16-18°C with humidity not over 55%. These conditions need cold air exiting the coil at about 6-7°C which is obviously not obtainable using chilled water at 7/12°C. It is therefore necessary, downstream of the standard chilled water cooling, to carry out a direct expansion post-cooling treatment which, using a specific cooling circuit, permits the necessary outlet conditions to be reached in order to satisfy the requirements. Air enters the post-cooling coil at 12-13°C saturated, and exits, still saturated, at 6-7°C; then the standard post-heating coil corrects the temperature to obtain the desired conditions. This cooling circuit complete with all its regulation and control components, is installed in the technical compartment of the machine and managed by

the machine's microprocessor. The axial-fan type air cooled condenser is installed outside and has to be connected to the cooling circuit on site. Alternatively, a water cooled condenser can be installed inside the machine, connected to tower water, mains drinking water or directly to the water from the chillers. In the last two cases, a pressure sensor is necessary for the condensing regulation. The circuit operates at critical temperatures which could bring about a risk of freezing the condensate on the coil with the consequent shut down of the machine itself. However, rigorous precautions are provided to guarantee the elimination of this risk.

Or to be integrated with the capacity of the chilled water circuit

This version has very useful applications in Hospitals where, due to thermal overload or because of the long distance between the installation and the chiller, the temperature of the water is two, three or four degrees above that intended and therefore the machine is not capable of guaranteeing all the capacity necessary for the required cooling and dehumidification.

serie H

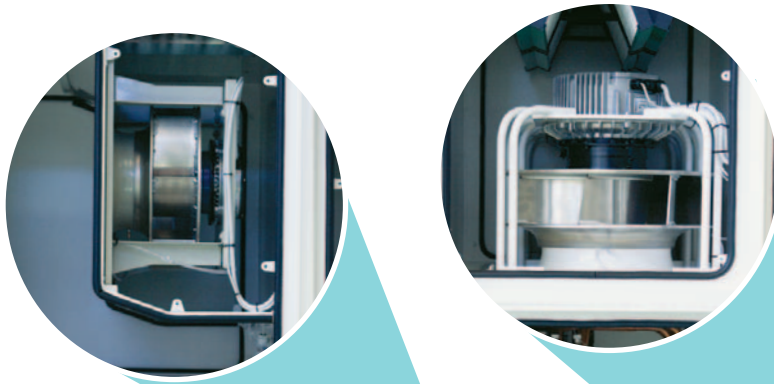

OHU 6800 HR-PC

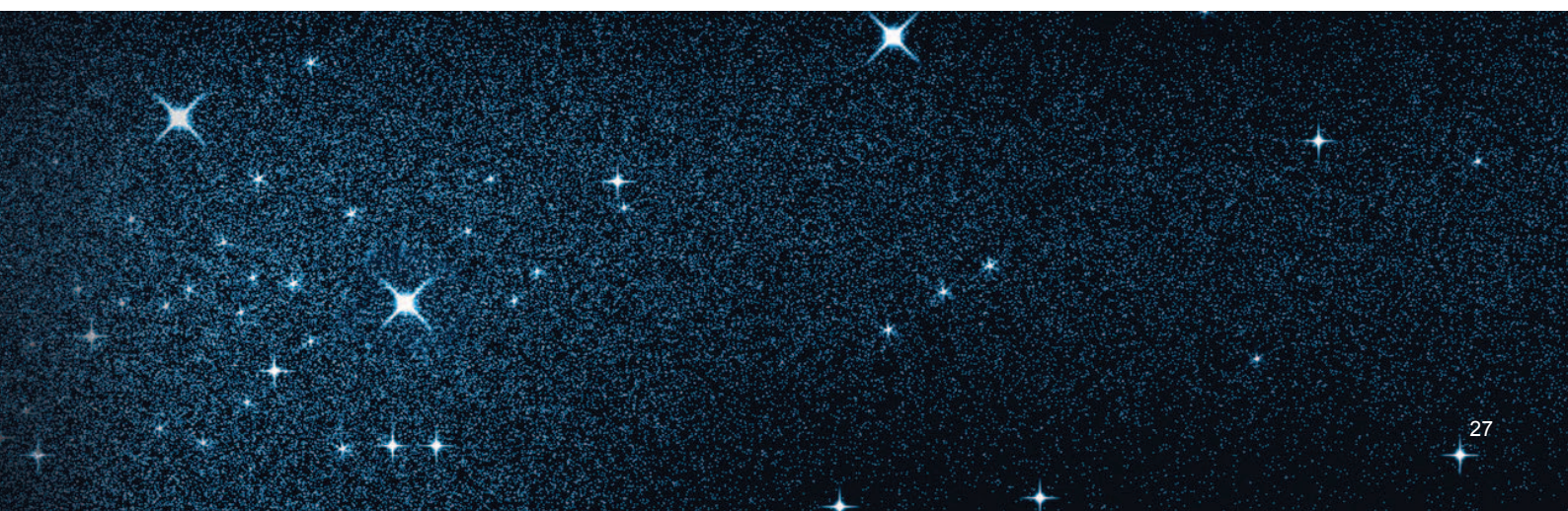
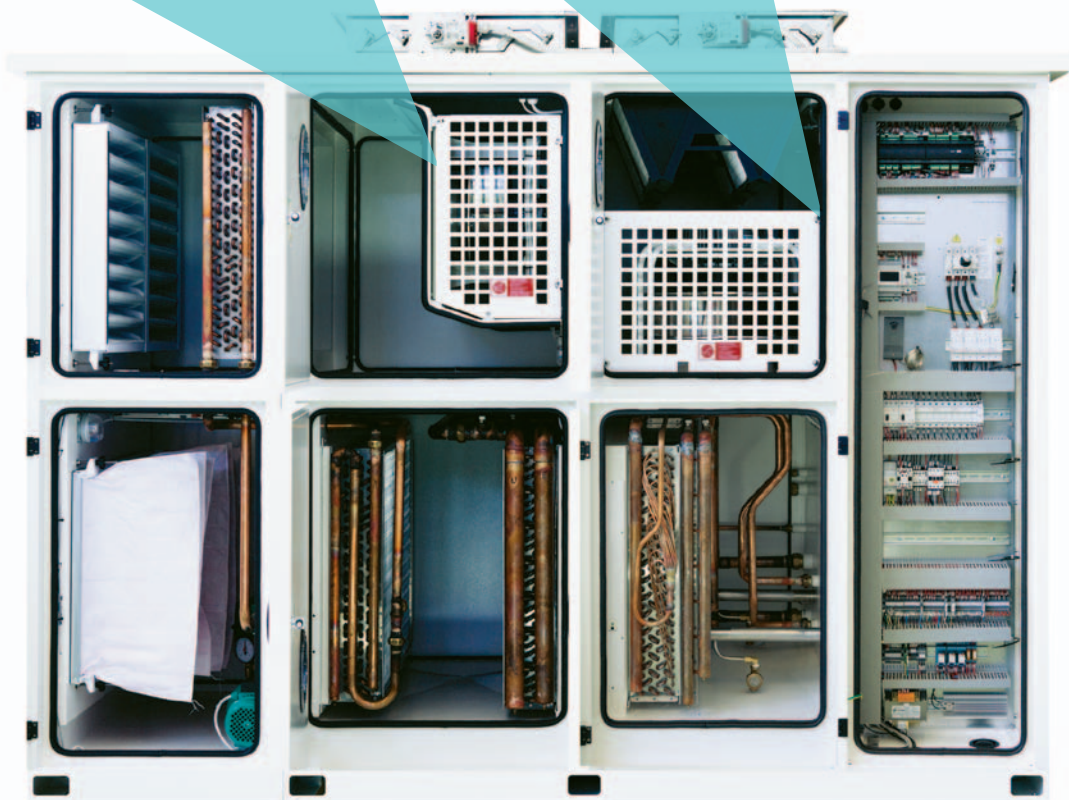

Energy saving

Night stand-by

When the room is not in use the flow of fresh air can be reduced to set limits, maintaining the area in overpressure and increasing the interval of inactivity for the control of temperature and humidity. The room is thus kept sterile without wasting energy. It should be noted that the supply airflow reduction can only be carried out if the dynamic control of overpressure has been selected as the room would otherwise go into depression. This important function, provided for in the standard software and managed by the microprocessor, can be called up manually, via BMS or time slots. In emergency operations the stand-by can be deactivated in order to return the unit rapidly to standard function values.

Versions with hydronic heat recovery system

Made up of two water coils, one in the suction section and an identical one in the fresh air

treatment section, connected by a hydraulic circuit with pump and expansion tank. The microprocessor starts the pump when the temperatures are favourable to energy saving. The hydraulic circuit is supplied empty as the percentage of glycol has to be determined as a function of the minimum temperature of the place of installation. It must therefore be filled on site to guarantee correct operation. The hydronic heat recovery system, although its performance is lower than that of a counter-current plate or rotary system, is capable of avoiding every type of cross-contamination between exhaust air and supply air.

System for the deactivation of components depending on the fresh air temperature

Depending on the temperature of the fresh air, the operation of some components which correct it is inhibited in order to avoid wasting energy.





One machine for each room









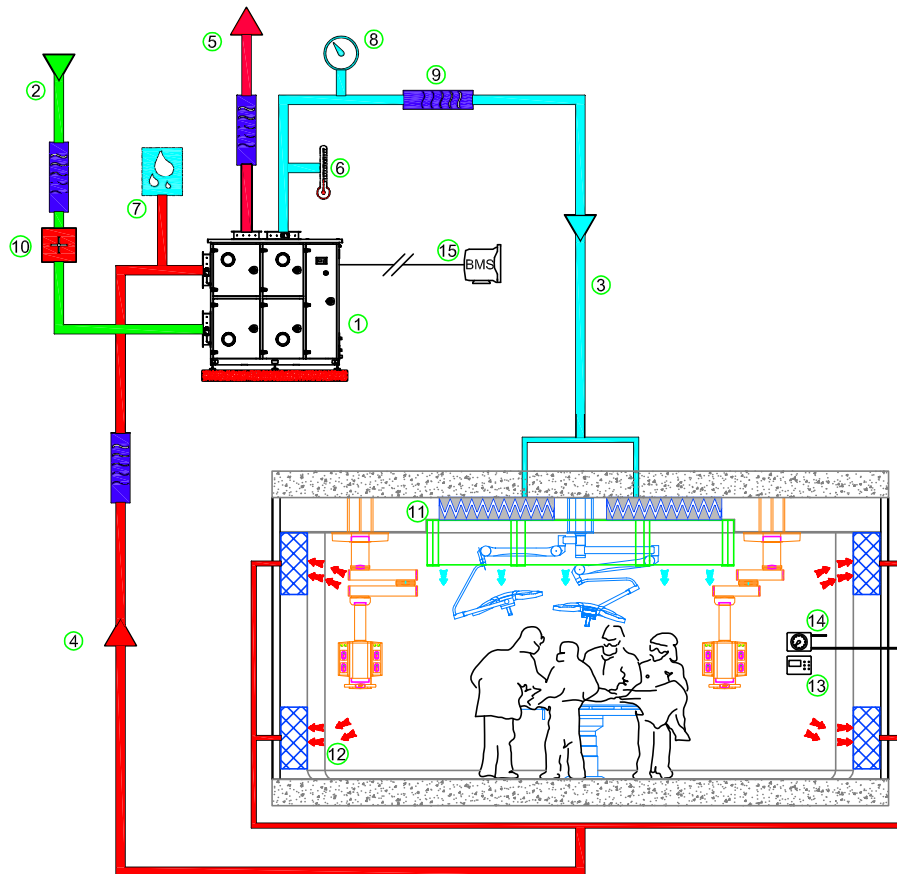





The most modern air conditioning plant technology calls for one machine to be installed in each surgical room. This makes it easy to manage the temperature and humidity required by the type of operation being carried out. In addition, the night-time stand-by can therefore be managed to provide maximum energy efficiency because the individual room does not have to be tied to the operation of any other rooms and can exploit to the maximum the opportunity of being ventilated with untreated air: for the same reasons it can also be sterilized without affecting the working operation of the other rooms. It is also worth taking into consideration the fact that, in the event of a machine component breaking down, only one

room would be put out of action. Finally, this plant design philosophy makes the ducting and regulation much simpler. Also the financial savings at first installation are not what they initially seem. In fact, the economic advantage of installing only one machine instead of three is greatly scaled down by the cost of additional components, the installation of many regulation systems (possibly in the difficult-to-get-at false ceiling space) and by the management problems of a more complex plant. For example, in the case of an operating block with six surgical rooms the optimum solution is to provide six identical installations - one for each room - and a seventh for all the ancillary rooms. The six machines are normally without heat recovery systems while the seventh has also an emergency double fan section for both supply and return/exhaust air.



Air conditioning plant for surgical room with unidirectional air filtration ceiling



- | | | |
|-----|--|---|
| 1. | Air conditioner for full fresh air or with partial recirculation | |
| 2. | Fresh air intake duct |  |
| 3. | Supply air duct |  |
| 4. | Return air duct |  |
| 5. | Exhaust air duct |  |
| 6. | Supply air temperature sensor for cold set point regulation |  |
| 7. | Return air humidity sensor |  |
| 8. | Supply airflow gauge |  |
| 9. | Damper on fresh air intake, room supply air, return air and exhaust air |  |
| 10. | Anti-freeze coil on the fresh air intake |  |
| 11. | Unidirectional filtration ceiling with H14 absolute filter |  |
| 12. | Suction filter grill |  |
| 13. | Remote control terminal (accessory) |  |
| 14. | Differential pressure sensor for the dynamic management of room overpressure |  |
| 15. | BMS System connection |  |









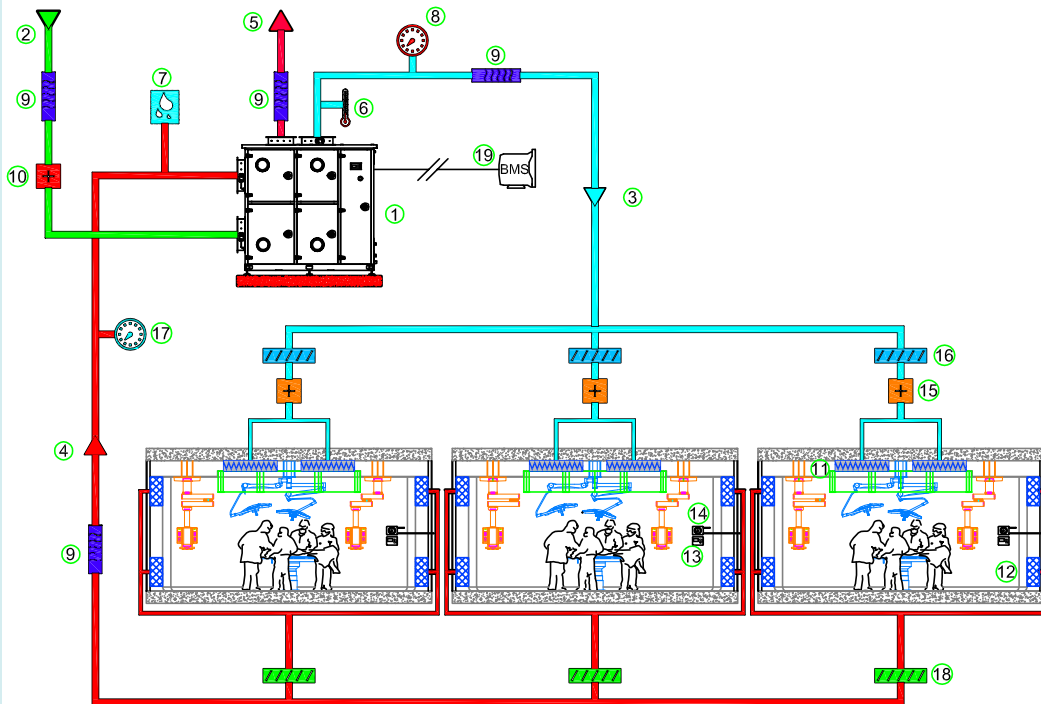









One machine for multiple rooms

It is possible however, if the layout of the plant requires it, to install a single air conditioner to serve several rooms. The following regulation systems have to be provided:

- supply airflow: controlled by the microprocessor to maintain constant pressure in the relative ducting. This means that if one of the controlled rooms is closed and the pressure rises, the microprocessor reduces the rotation speed so as to guarantee constant airflow to the rooms which remain open.
- Supply air temperature: controlled to set point, through a sensor installed at the mouth of the duct. The set temperature has to be cold enough to satisfy for the requirements of the room with the greatest need of cooling. Only available with chilled water versions.
- Air temperature in individual rooms: regulated by a hot water or electric post-heating coil installed in the duct going to the individual room, regulated by information coming from a sensor installed in the room itself.
- Supply air humidity: regulated by a sensor installed inside the machine in the return air section. This sensor detects the humidity in the returning air, which is the average humidity of the individual rooms.
- Airflow to the individual rooms: a CAV (constant air volume) damper with three positions is installed at the entrance to the individual controlled rooms: nominal airflow, reduced airflow (night-time stand-by) and stopped. The position of the damper is commanded from the room or via the BMS of the hospital.
- Overpressure of each individual room: a VAV (variable air volume) damper is installed in the return air duct of each room, regulated by information coming from a differential pressure sensor installed astride the wall separating the controlled rooms and a reference area, normally the clean corridor.
- Return/exhaust airflow: regulated by the machine microprocessor to maintain constant depression in the return/exhaust duct in order to be able to activate the VAV dampers in each individual room.

Air conditioning plant for three surgical rooms with unidirectional filtration ceilings



- | | | |
|-----|--|---|
| 1. | Air conditioner for full fresh air or with partial recirculation | |
| 2. | Fresh air intake duct |  |
| 3. | Supply air duct |  |
| 4. | Return air duct |  |
| 5. | Exhaust air duct |  |
| 6. | Supply air temperature sensor for cold set point regulation |  |
| 7. | Return air humidity sensor |  |
| 8. | Supply air pressure sensor |  |
| 9. | Damper on fresh air intake, room supply air, return air and exhaust air |  |
| 10. | Antifreeze coil on the fresh air intake |  |
| 11. | Unidirectional filtration ceiling with H14 absolute filter |  |
| 12. | Suction filter grill |  |
| 13. | Remote control terminal |  |
| 14. | Differential pressure sensor for the dynamic management of room overpressure |  |
| 15. | Post heating water or electric coil controlled by a temperature sensor inside the room |  |
| 16. | Supply airflow regulation (CAV damper) box |  |
| 17. | Return air pressure sensor |  |
| 18. | Return airflow regulation (VAV damper) box for the management of room overpressure |  |
| 19. | BMS System connection |  |

Plant for diagnostic imaging

General characteristics

The air conditioning plant for a magnetic resonance department serves three separate areas, all of which have quite different characteristics and requirements:

1. Examination room
2. Control room
3. Technical room

1. Examination room

This is a volume of roughly 100-120 m³, without a raised floor and therefore with air distribution from above. It is characterized by the presence of the scanner and the consequent dissipation of its heat, about 4 kW, and by its helium charge for cooling the magnet. It is this helium charge (about 100 kilos) which in the event of any leakages could create severe respiratory problems for the patient.









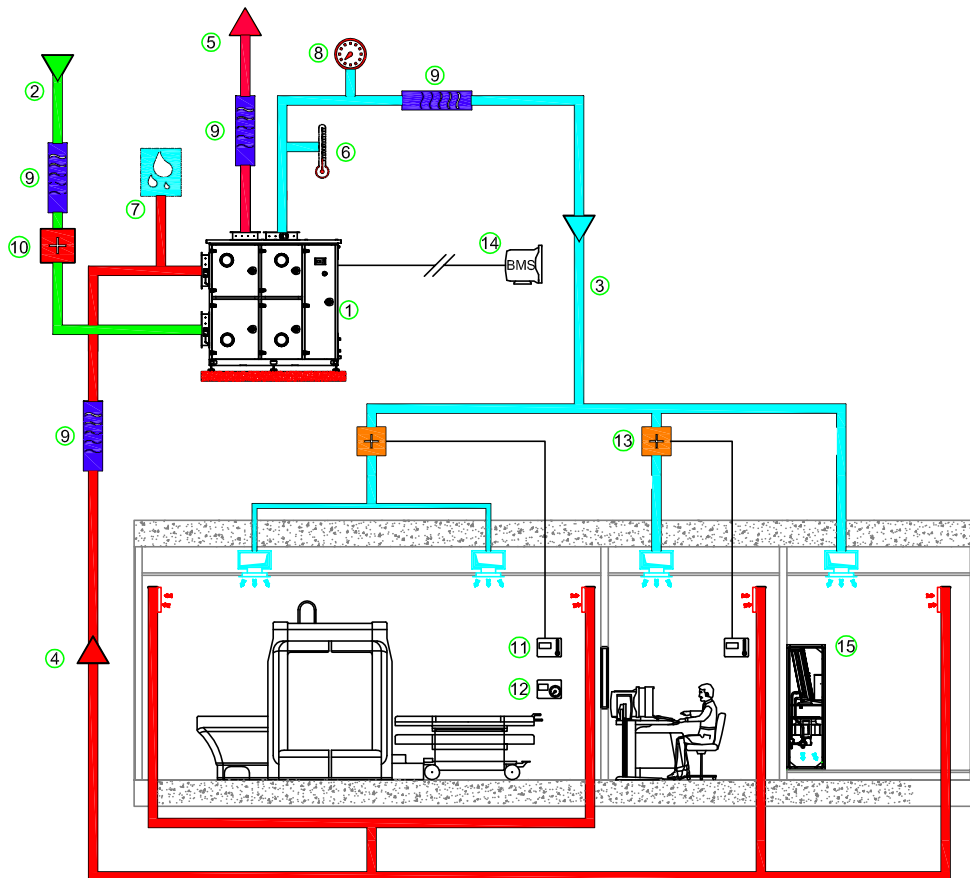



The characteristics of the air conditioning plant for this room are as follows:

- supply airflow (full fresh air), approx. 10 volumes per hour, therefore about 1,200 m³/h.
- Air filtration: standard F7, maximum F9, already guaranteed by the air conditioner, so without final air filtration.
- Exhaust airflow: approx. 1,000 m³/h, 60% of which is from the magnet and the rest is returned air expelled from the air conditioner;
- Ambient conditions: temperature 24°C ± 2°C; humidity 50% ± 5%.
- Sensible cooling: approx. 5 kW.
- Emergency functioning (helium leakage): an oxygen-quantity detector informs the air conditioner's microprocessor of any alarm condition due to the probable escape of helium. The microprocessor activates the emergency software, sets off an acoustic and visible alarm and doubles both the supply and return/exhaust airflow in order to dilute the presence of helium and to guarantee the respiration of the patient and the health care workers.



Air conditioning plant for magnetic resonance departments



- | | | |
|-----|--|---|
| 1. | Chilled water air conditioner for full fresh air | |
| 2. | Fresh air intake duct |  |
| 3. | Supply air duct |  |
| 4. | Return air duct |  |
| 5. | Exhaust air duct |  |
| 6. | Supply air temperature sensor for cold set point regulation |  |
| 7. | Return air humidity sensor |  |
| 8. | Supply airflow gauge |  |
| 9. | Sound damper on fresh air intake, room supply air, return air and exhaust air ducts |  |
| 10. | Antifreeze coil on the fresh air intake |  |
| 11. | Room temperature sensor for the regulation of the post heating coil |  |
| 12. | Differential pressure sensor for the dynamic management of room overpressure |  |
| 13. | Post heating water or electric coil controlled by a temperature sensor inside the room |  |
| 14. | BMS System connection |  |
| 15. | Chilled water close-control air conditioner with downward discharge | |

2. Control room

This has a volume of approx. 70 m³.

Plant characteristics:

- supply airflow (full fresh air); 6 volumes/hour, so about 450 m³/h;
- air filtration: standard F7, maximum F9;
- exhaust airflow: about 400 m³/h;
- ambient conditions: temperature 22°C ± 2°C; humidity: 50% ± 5%;
- sensible cooling: about 1.5 kW.

3. Technical room

This has a volume of approx. 70 m³; it normally has a raised floor and therefore the air conditioner treating the recirculation air discharges downwards.

Plant characteristics:

- supply airflow (full fresh air): 2 volumes/hour, therefore about 150 m³/h;
- recirculation airflow: about 4,000 m³/h;
- air filtration: F7, maximum F9 for the fresh air; G4 for the recirculation air;
- exhaust airflow: about 50 m³/h;
- ambient conditions: temperature 22°C ± 2°C; humidity: 50% ± 5%;
- sensible cooling: about 20 kW.

Construction characteristics

1. Plant

The plant, which is normally completely separate from the air conditioning system of the hospital, uses full fresh air with integrated local recirculation only in the machine room.

Temperature regulation is by set point with the sensor in the supply compartment and the humidity sensor in the return air compartment.

The constancy of the supply airflow is guaranteed by a continuous measurement device and correction by an inverter on the fan.

2. Air conditioner for fresh air

Air conditioner for the treatment of full fresh air, having the following characteristics, model OHU 2200:

- mono-block unit complete with controls, electrical panel, microprocessor and specialized software, certified to UNI/EN 1886.
- The air conditioner normally has a chilled water coil; direct expansion coil available as an alternative.

- Normally without a heat recovery system, due to both the low airflow and to the fact that part of the exhaust is done by the magnet and therefore is not returned to the air conditioner.
- Motorised damper on the fresh air intake.
- G4 fresh air pre-filter.
- Hot water heating coil with microprocessor-controlled three way valve functioning in mixing and the related spill-back pump.
- Chilled water cooling coil with microprocessor-controlled three way valve functioning in deviation.
- Post-heating coil with microprocessor-controlled three way valve functioning in deviation.
- Modulating steam humidifier with immersed electrodes controlled by microprocessor.
- Supply fan with electronic speed regulator and airflow meter.
- F7 or F9 efficiency supply air filter.
- F5 efficiency return air filter.
- Return/exhaust fan with inverter to regulate the necessary room overpressure.
- RS485 board to connect to the remote control system of the hospital.



3. Supply and return air ducting and accessories

Externally insulated galvanized sheet metal, airtight to at least class B:

- always fitted with a sound damper in the supply and return air duct.
- The necessity of having sound dampers installed in the fresh air intake and the exhaust air outlet duct is dependent upon the evaluation of the impact on the external surrounding area.
- Post-heating coil on the supply duct to the examination and control rooms; it is not essential on the duct to the machine room because that area always produces enough heat itself; normally a hot water coil is used, regulated by a three way modulating valve which is controlled by a sensor installed in the controlled room, alternatively an electric coil with TRIAC regulation can be used.

4. Air conditioner for the machine room

Chilled water with downward discharge of the supply air, model UCU 30. The supply air flow is regulated automatically as a function of the power required by the electronic equipment. A sensor in the air conditioner installed in the return duct regulates the temperature. Post-heating and humidification is not necessary as these functions are already guaranteed by the treatment of the fresh air.



serie H



Accessories

Numerous accessories are available to customise the unit according to the requirements of the application:

- Second user interface terminal for remote control of the machine.
- Cooling capacity control of the compressor (OHA model only), for perfect modulation of the cooling circuits as a function of the external conditions. This is indispensable for the treatment of full fresh air.
- Double electronic supply fan installed in parallel with the standard fan to guarantee maximum operating safety.
- Double electronic return air and exhaust fan installed in parallel with the standard fan to guarantee maximum operating safety.
- F7 filter instead of the standard G4 at the inlet of the machine.
- F9 filter instead of the standard F7 at the outlet of the machine.
- Air recirculation damper, motorized, modulating and counter-opposed to the fresh air one.
- Motorized dampers on all vents.
- Motorized dampers on all vents, airtight level 4 to standard DIN 1751.
- Water cooled plate condenser.
- Two-way pressure sensor valve.

- Temperature and humidity sensors supplied loose instead of installed in the return section.
- Temperature sensor in the supply fan section (cold point regulation) and humidity sensor in the return section.
- Pressure sensor to read the supply airflow with constant pressure regulation.
- Specific gateways for integration with BACnet or Lonworks systems.
- Specific gateways for remote management via internet (TCP/IP) and via GSM modem with SMS sending capability.
- Hydronic heat recovery system.
- Epoxy painted coil fins.
- Direct expansion post-cooling system for heart surgery.
- Modulating centralized steam distributor instead of an autonomous immersed-electrode version.
- Immersed resistance humidifier instead of the immersed-electrode type.
- Sealed internal lighting to enable correct-function checks of the machine without having to open it.
- Water presence alarm.



Operating performance (without heat recovery)

OHA models with remote air cooled condenser

Models		2.200	3.600	4.600	6.800	11.400
Cooling capacity (1)	kW	21,5	36,1	43,8	69,6	98,9
Airflow (2)	m ³ /h	2.200	3.600	4.600	6.800	11.400
Sound Pressure Level (3)	dB(A)	55	57	62	62	64

OHU models with chilled water coil

Models		2.200	3.600	4.600	6.800	11.400
Cooling capacity (1)	kW	22,5	37,0	44,0	65,4	98,4
Airflow (2)	m ³ /h	2.200	3.600	4.600	6.800	11.400
Sound Pressure Level (3)	dB(A)	54	56	57	59	62

Note:

- (1) The performances are referred to: refrigerant R410; condensing temperature: 45°C; for chilled water: 7/12°C; external inlet air: 32°C - 40% RH.
The above performances don't consider the heat generated by the fans which must be added to the thermal load of the system.
- (2) Static pressure: 800 Pa.
- (3) The SPL is referred to 2 m distance, 1,5 m height, free field and with sound damped vents.

Dimensions and weights

OHA\OHU models:

Models		2.200	3.600	4.600	6.800	11.400
Length	mm	1.980	2.280	2.280	2.280	2.280
Depth	mm	930	1.020	1.020	1.308	1.858
Height	mm	1.875	2.180	2.180	2.180	2.180
Net weight (OHA)	kg	650	900	950	1200	1500
Net weight (OHU)	kg	600	800	800	1000	1300

OHA-HR\OHU-HR\OHU-PC\OHU-HR-PC models:

Models		2.200	3600	4.600	6.800	11.400
Length	mm	2.680	2.980	2.980	2.980	2.980
Depth	mm	930	1.020	1.020	1.308	1.858
Height	mm	1.872	2.180	2.180	2.180	2.180
Net weight (OHA-HR)	kg	800	1100	1150	1450	1800
Net weight (OHU-HR)	kg	750	1000	1000	1250	1600
Net weight (OHU-PC)	kg	750	1000	1000	1250	1600
Net weight (OHU-HR-PC)	kg	850	1150	1150	1450	1850

serie **H**





TECNAIR LV

SURGICAL ROOM AIR CONDITIONING

TECNAIR LV S.p.A.

21040 Uboldo - Varese - Italy
Via Caduti della Liberazione, 53
Phone + 39 02.96.99.11.1
Fax. + 39 02.96.78.15.70
E-mail: sales@tecnairlv.it
www.tecnairlv.it



GOST certification



TECNAIR LV has a policy of continuous development, so the company reserves the right to modify and improve any product described in this document without notice. Technical data and dimensions are not binding.