

IMD 95Y, 135Y, 170Y, 210Y, 280Y (c/w EC motor)

Ducted Fan Coil Unit

Installation & Maintenance

Dimensions (mm)

Not to Scale

Fig. 1 IMD 95Y

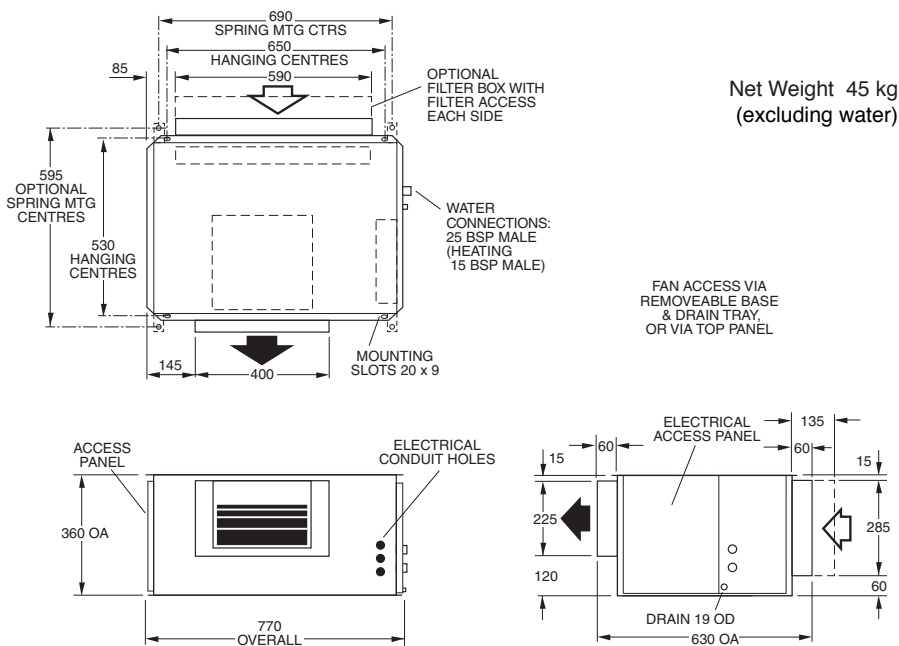

Net Weight 45 kg (excluding water)

GENERAL

The IMD ducted fan coil units must be installed in accordance with all national and local safety codes.

Options

1. Filter Box
2. Spring Mounting Kit

FILTER BOX (Option)

The Filter Box is installed by unscrewing the return air spigot and replacing it with the Filter Box's filter-integrated spigot. The filter may be accessed from either side of this spigot. This new spigot has a depth of 135 mm, instead of 60 mm.

INSTALLATION

Positioning & Mounting

Provide 500 mm minimum clearance to both ends of the unit. If the filter box option is to be used, allow adequate clearance for the filter to be withdrawn to its full length.

If low noise is a critical factor in the installation, refer to Figure 8 for noise isolation recommendations.

It is recommended that the unit be mounted using the spring mounting system, supplied as an optional extra (Fig.5). This system minimises transfer of vibration into the building structure.

If a more rigid installation can be tolerated, then suspend the unit from four threaded rods (not supplied) and use locknuts (not supplied), as shown in Figure 6.

The unit has a built-in sloping drain tray, therefore mount it level.

When finally positioned, tighten the lock nuts on the mounting rods from above and below the mounting flange to give a firm installation (see Fig. 6).

Condensate Drain

The condensate drain should be trapped outside the unit cabinet. The trap should have a vertical height of at least 50 mm. The drain should have a slope of at least 1 in 50 and must not be piped to a level above the unit drain tray. (Refer Fig.7).

For long condensate pipe runs, fit a vent pipe near the drain trap. The top of the vent pipe must be at least 100 mm above the IMD unit's drain tray.

It is essential that the drainage system is checked by pouring water in the drain tray and seeing that it discharges at the end of the drain and does not overflow the drain tray.

Note: The built-in drain tray can be removed for cleaning (or fan access) by first removing the unit's base.

Fig. 2 IMD 135Y, 170Y

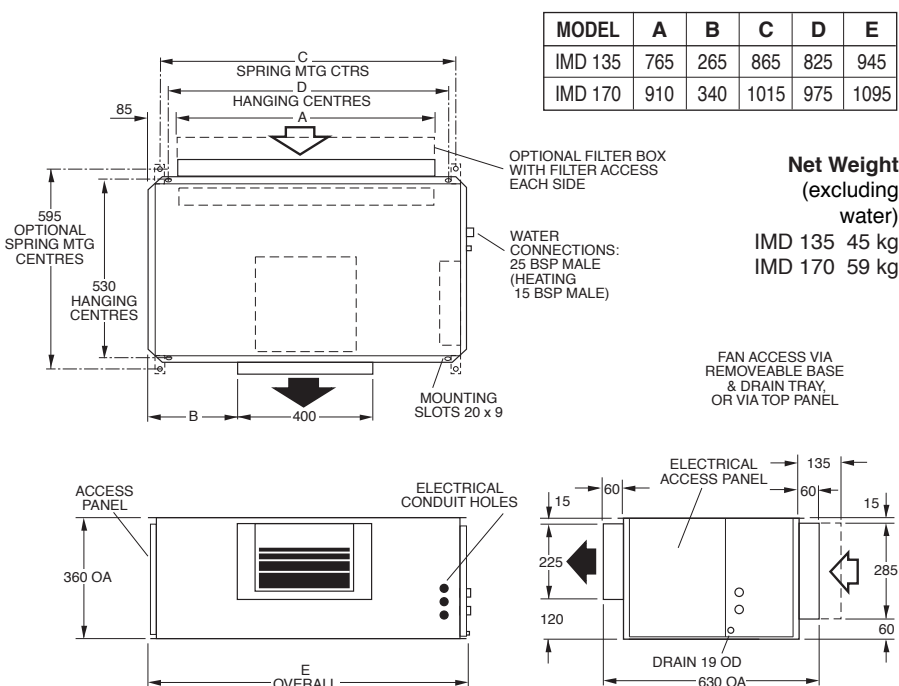

ELECTRICAL WIRING

The electrical supply required (including voltage fluctuation limits) is:
1 phase 200-252 V a.c. 50 Hz with neutral and earth. The supply to have an isolation switch adjacent to the unit but not attached to the unit. Recommended external circuit breaker size is 10 amp.

Electrical work must be carried out by a qualified electrician in accordance with local supply authority regulations and the wiring diagram.

INDOOR FAN SPEED

The indoor fan can be switched ON by selecting High, Medium or Low fan speed on the terminal block, or via BMS. This can be done without starting the compressor.

The indoor fan speed can be 'Stepped' or 'Continuously Variable'. Dip switches 1 to 5 on the Analogue Level Controller (ALC) determine the minimum and maximum fan speeds. The same 'Minimum rpm' and 'Maximum rpm' settings apply to 'Stepped' and 'Continuously Variable'.

The default settings for max. fan speed and fan speed range are highlighted on the Wiring Schematic.

1. Stepped (3 Speed)

Connecting the COM power terminal to one (and only one at a time) of the LOW, MED or HIGH speed terminals sets a single fan speed. Connecting the COM power terminal through a 3 speed switch (not supplied) will allow manual speed selection.

LOW will select the minimum rpm, HIGH will select the maximum rpm, MED will select mid-way between the two speeds. The speeds' separation depends on the setting of Analogue Level Controller (ALC) dip switches 4 & 5. The transitions between speeds are smooth.

2. Continuously Variable (0-10V Control)

This option is active when 0.5V or more is input to the ALC Controller's 0-10V input terminal.

A voltage below 1.6V DC applied across the '0V' and the '0-10V' input terminals will stop the indoor fan. A control voltage of 2V or more will cause the fan to run at the 'Min. rpm' speed. The 'Min. rpm' depends on the setting of Analogue Level Controller (ALC) dip switches 4 & 5. A 10V DC signal will run the fan at the 'Max. rpm' speed. Control voltages between these two limits can be used to achieve any desired speed between 'Min.' and 'Max.' rpm.

If the air returning to the indoor unit is regularly expected to be above 50%RH, then the coil face velocity should be limited to be 2.5 m/s or less (refer Air Handling graph in Technical Data pamphlet).

High humidity levels can occur in tropical or subtropical conditions, and/or when heavily moisture laden fresh air is introduced. Select a fan speed that avoids water carry-over problems.

COMMISSIONING

1. Check that the thermostat is correctly wired and set at the desired temperature.
2. Check that the air filter (if fitted) is clean.
3. Check that the fan runs freely without vibration.
4. Check condensate drain for free drainage.

Fig. 3 IMD 210Y

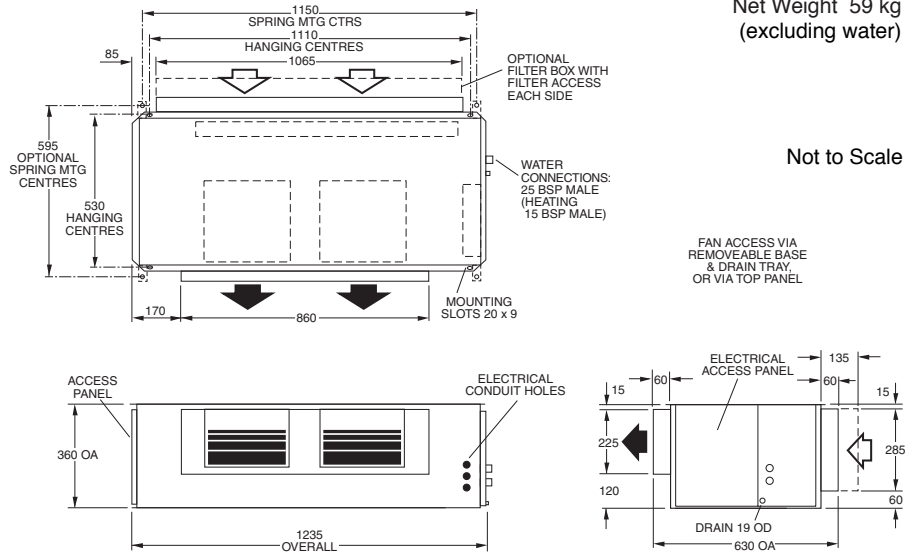

Fig. 4 IMD 280Y

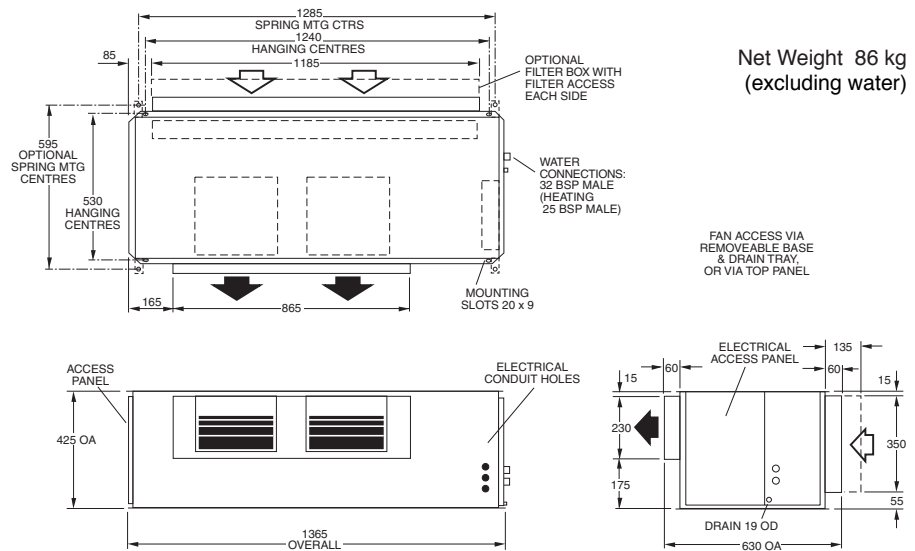

Fig. 5 Spring Mounting

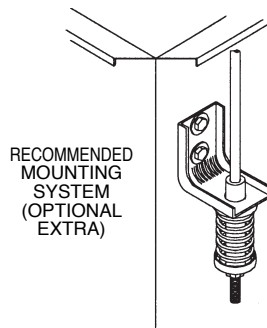

Fig. 6 Solid Mounting

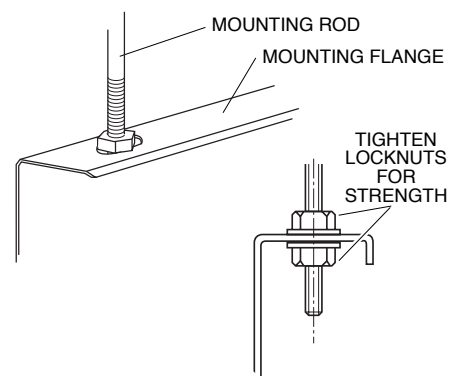
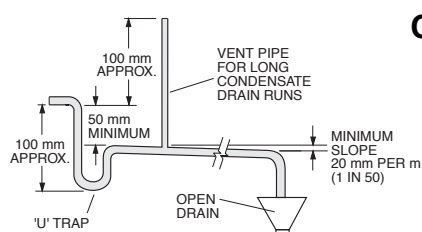

Fig. 7



Condensate Drain

MAINTENANCE

Weekly For First Four Weeks

1. Check air filter (if fitted); vacuum clean as necessary.
2. Check condensate drain for free drainage.

Monthly

Check air filter (if fitted); vacuum clean as necessary.

Six Monthly

1. Check condensate drain for free drainage.
2. Check heat exchanger coil; vacuum or brush clean as necessary.
3. Check the tightness of the fan.
4. Check that fan motor is free running.
5. Check tightness of electrical connections.
6. Check air supply at diffuser outlets.

NOTE

The manufacturer reserves the right to change specifications at any time without notice or obligation. Certified dimensions available on request.

This pamphlet replaces the previous issue no. 3989 dated 08/15.
Wiring revision B.

Fig. 8 Application Considerations

Recommendations for Noise Isolation

- particularly for high static installations:

1. Avoid installing units, with non-ducted return air, directly above spaces where noise is critical.
2. Use flexible connections between unit and rigid ducting.
3. Use generously sized acoustically lined ducts.
4. If generous duct size is not possible, use turning vanes on bends to reduce air turbulence (regenerated noise).
5. Use 90° bends in ducting to significantly assist in noise reduction.

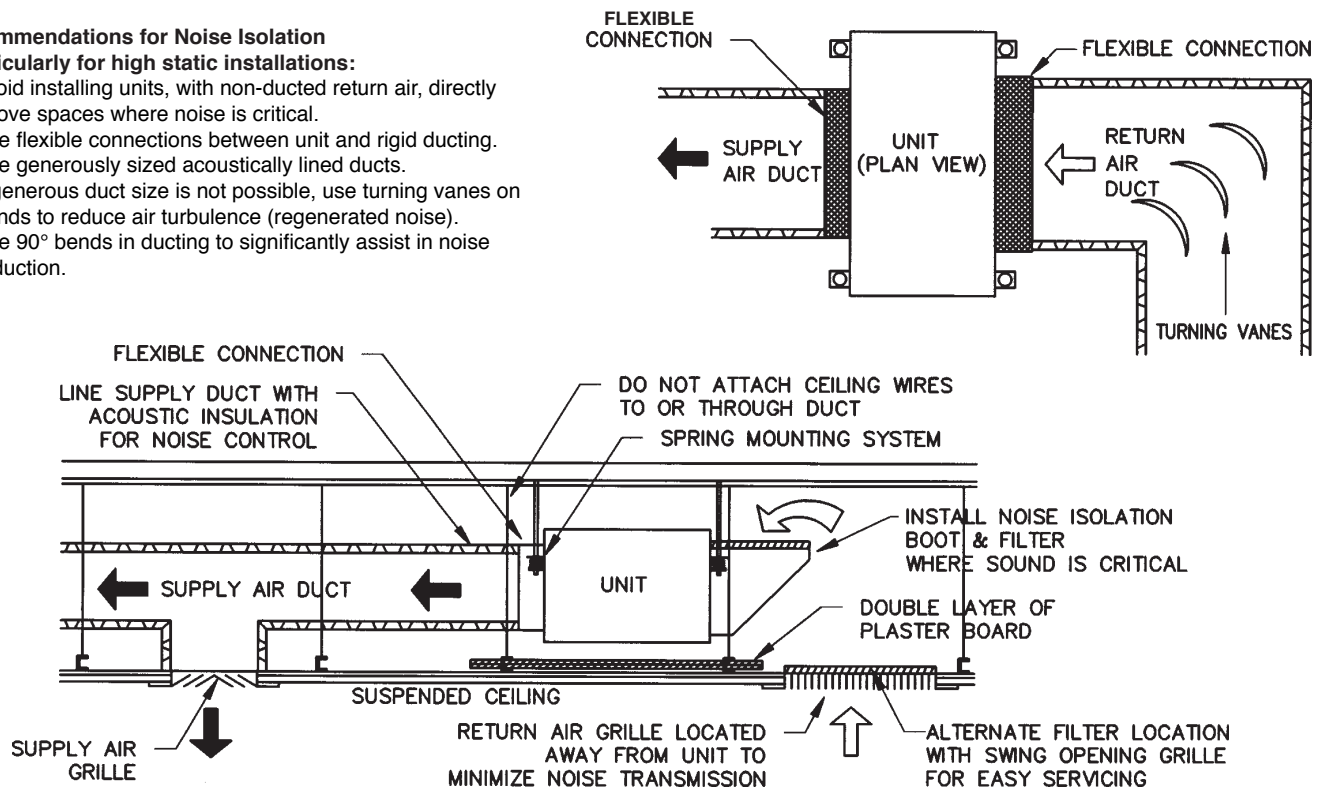

DIP SWITCH SETTINGS

DO NOT USE ANY OTHER DIP SWITCH COMBINATIONS EXCEPT THOSE SHOWN IN THE TABLE BELOW. SHADED AREA = DEFAULT SETTINGS

Indoor Fan Speed ALC DIP s/w settings	
DIP Switch	
Max Speed Setting	Max Fan RPM
1 2 3	1000
0 0 0	1100
0 1 0	1200
1 1 0	1250
0 0 1	1300
1 0 1	1350
0 1 1	1400
1 1 1	1500

DIP Switch	
Speed Range	Fan Range RPM
4 5	300
1 0	450
0 1	600
1 1	900

DIP Switch	
Run On	(sec)
0	40 Standard
1	120 Elec. Heat

DIP Switch 7 & 8 - OFF -

ABOVE SPEED SETTING SETS THE MAX. SPEED/VOLTAGE (HIGH), THE SPEED RANGE SETS THE DIFFERENCE BETWEEN THE MAX. SPEED AND MIN. SPEED/VOLTAGE(LOW). WITH 3 SPEED CONTROL THE MEDIUM SPEED IS ALWAYS HALFWAY BETWEEN HIGH AND LOW.

NOTE:
1) DO NOT CONNECT BOTH 3 SPEED L/M/H SWITCH AND ALSO BMS 0-10V (DC) SIGNAL ONLY ONE CONTROL METHOD MAY BE CONNECTED AT A TIME.
IF IN DOUBT ASK!

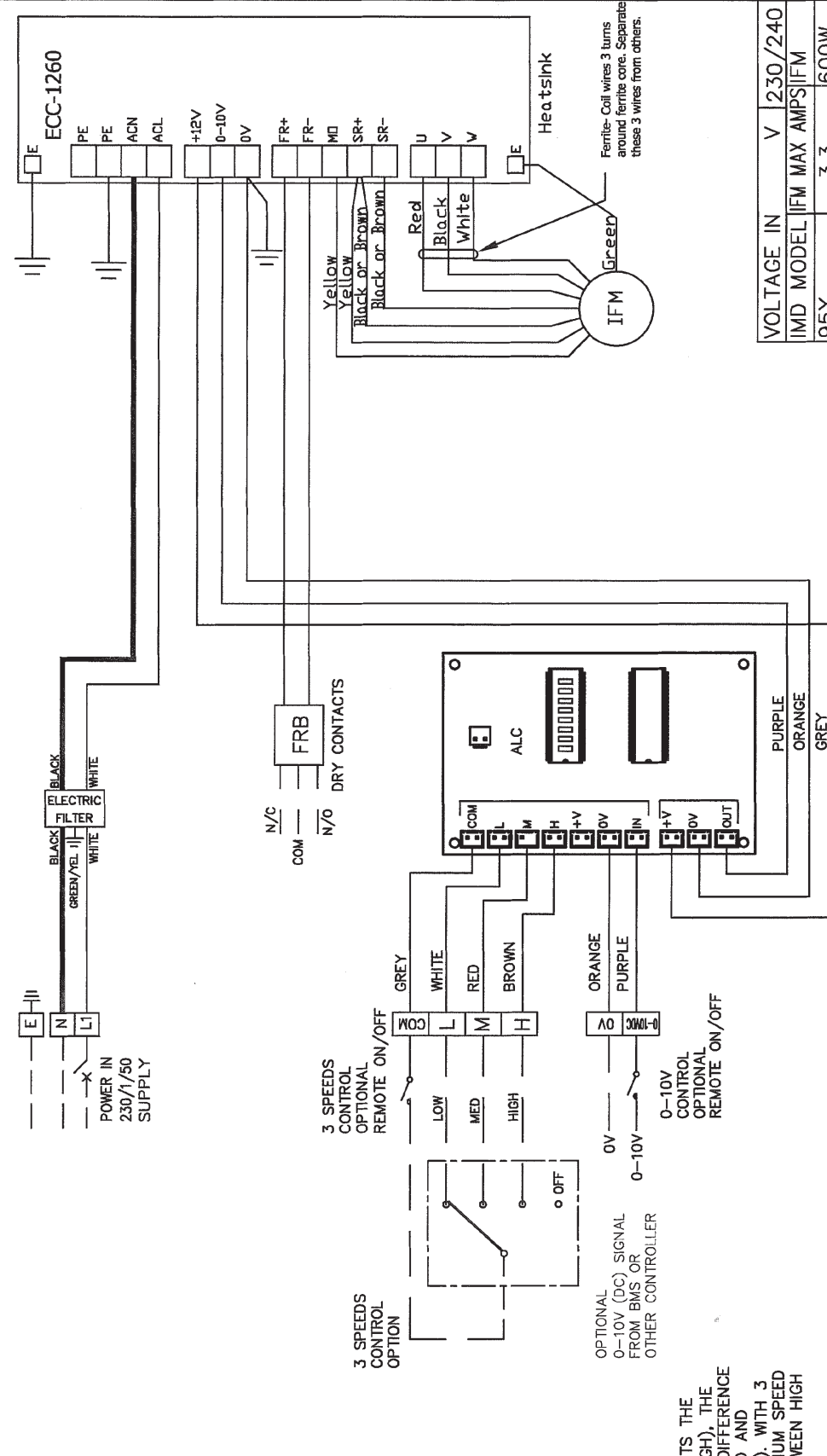

VOLTAGE IN	V	230/240
IMD MODEL	IFM MAX AMP/IFM	
95Y	3.3	600W
135Y	4.9	900W
170Y	6.8	1.25kW
210Y	6.8	1.25kW
280Y	6.8	1.25kW

Title **IMD 95,135,170,210,280Y WIRING SCHEMATIC**



Drawn	K.L.E	Date	25-11-14	Drawing No.	291-000-162	Revision	B
Scale		Approved	PCG				

ALC	ANALOGUE LOGIC CONTROLLER.
IFM	INDOOR FAN MOTOR
FRB	FAULT RELAY BOARD
- - - - -	CLIENT WIRING

B	CHANGED EARTHING ARRANGEMENT, REMOVED TERM. 1 & 2 FOR REMOTE ON/OFF	25-9-15	W.A.S.
A	EC MOTOR/DRIVER CHANGED, ALC ADDED & WIRING COLOURS CHANGED TO MATCH STD PRODUCTS	20-8-15	W.A.S.
ISSUE	MODIFICATION	ECN	DATE
			APRVD