

PRODUCT BROCHURE

SMARTEMP[®]
IN COMFORT



Fixed Helical Swirl Diffuser

HSC-FD

HSC-FD : 062024

smartemp.com

DESCRIPTION

The SMARTEMP® Fixed Helical Swirl Diffuser, type HSC-FD, produces highly inductive swirl discharge, diffusing the supply air stream radially with fixed horizontal discharge and strong mixing characteristics into the space. The patent pending design delivers high levels of draught-free comfort well suited to both constant volume or VAV applications, inclusive of low temperature or cold air supply air systems with a minimum supply-to-room temperature differential of -16 K including turndown to approximately 25%.

The diffuser comes standard with a square face (figure 1), or may optionally be ordered with a round face.

The cambered leading edges of the twenty off-set radial vanes reduce the sound power level and pressure drop, improving aural comfort and saving fan energy.



Figure 1

Fixed Helical Swirl Diffuser
HSC-FD : 062024



Figure 2

CONSTRUCTION

- 1 - M6 Thread Rod
- 2 - Reducer (Optional)
- 3 - HSC-FD Swirl Diffuser
- 4 - Diffuser

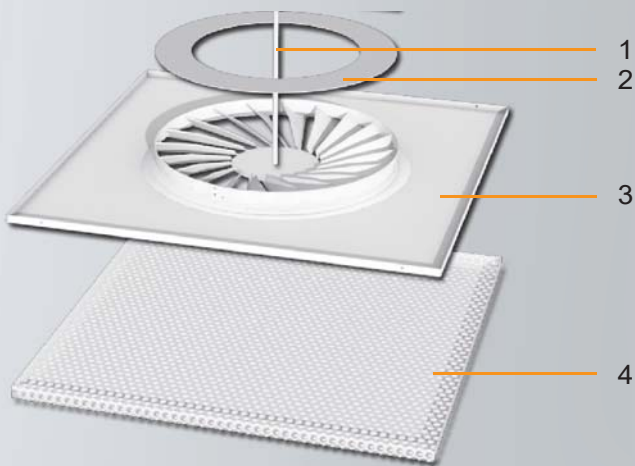

Figure 3

The vane tips feature helical twist (figure 2) that reduces pressure drop, allowing the airflow rate to be increased, thereby reducing the number of diffusers required in the space. This unique feature also reduces the minimum permissible VAV turndown to 22% at -12 K cooling or 25% at -16 K (based on 35 Pa maximum total pressure) and enhances stable operation under low supply air temperature conditions.

The HSC-FD diffuser may be flush mounted in a ceiling or, if the circular variant is used, freely suspended (ie no Coanda attachment to the ceiling required). Typical discharge height ranges from 2.0 to 4.5 m, depending on diffuser size and airflow.

The highly inductive swirl discharge benefits heating performance by strongly diluting supply air with cooler room air, thereby diminishing supply air stream buoyancy. The maximum recommended differential between supply air and room air is a function of diffuser size, discharge height and airflow rate.

The HSC-FD swirl vanes form a flush surface with the surrounding flat diffuser face, which may be square or round, and which may be optionally screened by a perforated face. The diffuser is made of powder coated steel and is available with nominal neck diameters of 250 mm, 355 mm and 500 mm. Optional reducers are available to reduce effective neck size for decreased airflow rates.

Reducers

Reducers can be inserted into the neck from behind, reducing the effective neck size to suit reduced airflow rates, especially in low air quantity VAV applications (figure 4). Reducers allow a largely uniform diffuser aesthetic to be achieved by enabling the use of a common diffuser size even where airflow rates between diffusers vary widely. The ability to simply change reducer size also provides future-proofing for refurbishment and fit-out changes. Five reducer sizes are available for size DN500 and six for size DN355. Reducers are not available for size DN250.

Discharge Pattern

Segment covers that blank one half, two opposed quarters, or one quarter of the diffuser vanes are available to reduce the discharge pattern from 360 ° to 180° (2-way asymmetrical), or 2 x 90° (2-way symmetrical), or 270 ° (3-way) so as to allow for diffuser placement in corners, in corridors, or close to a wall, respectively (figure 5). Segment covers reduce the diffuser airflow rate. Segment covers may be used in combination with reducers where further airflow rate reductions are required.

Mode of Operation

The highly inductive swirl discharge of the HSC-FD produces rapid discharge velocity decay as the total supply air stream mass flow rate increases due to strong entrainment of secondary air from the room into the primary air stream. Effective air changes per hour are increased.

Fixed Helical Swirl Diffuser

HSC-FD : 062024

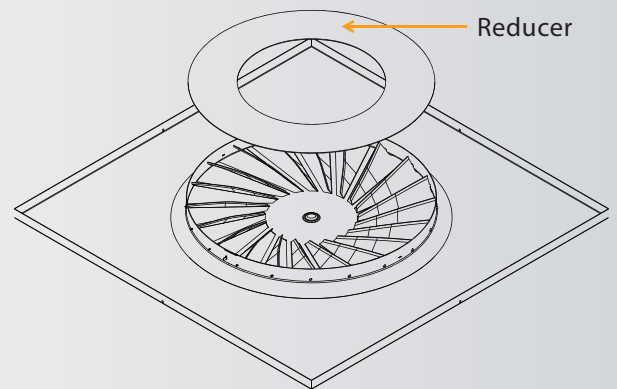

Figure 4

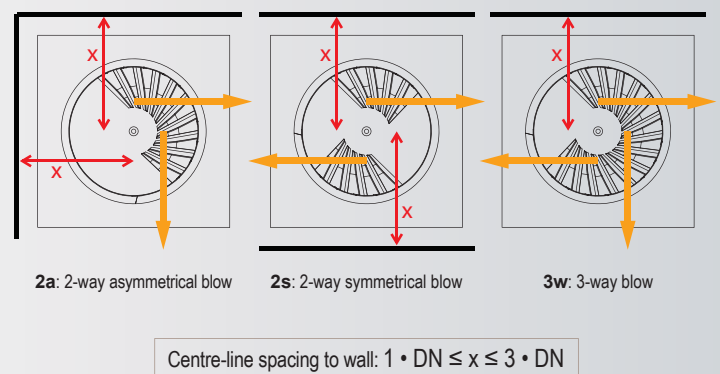

Figure 5

TECHNICAL DATA

1 - HSC-FD-C - circular face (suitable for freely suspended applications)

2 - HSC-FD-S - square face

3 - Generic connection box - please refer to Selection Tool for low profile alternatives

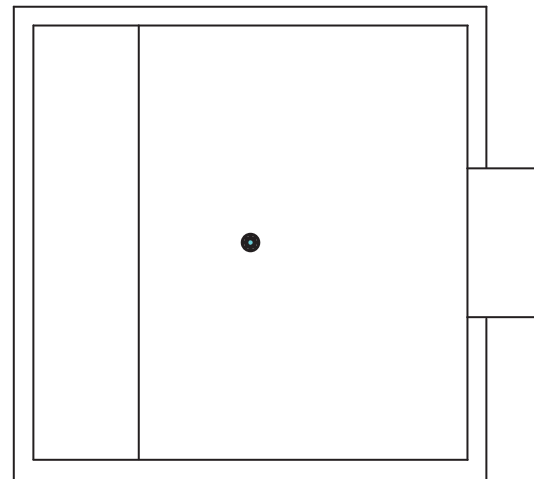
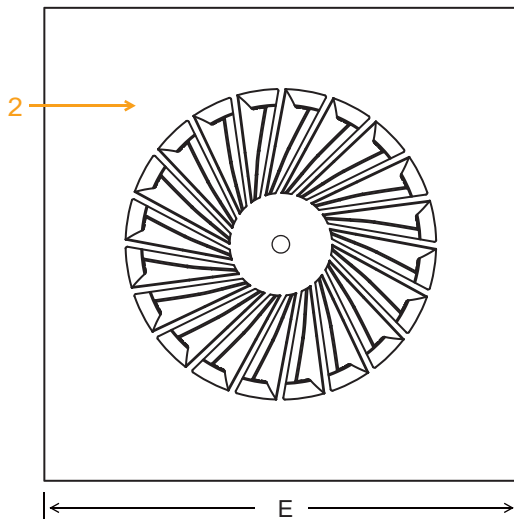
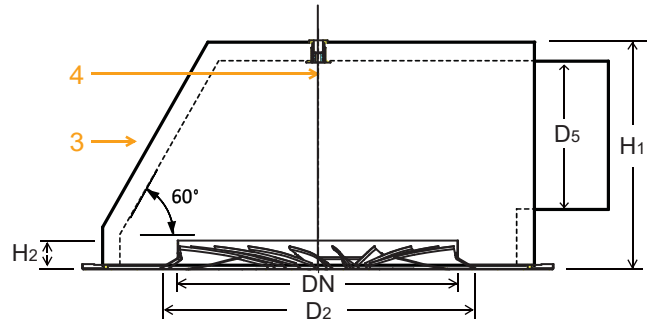
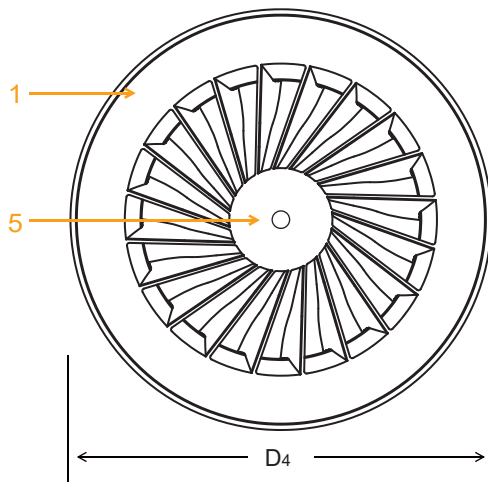

Nominal diameter DN	Ceiling grid	Reducer size	Volume flow rate ¹⁾			Dimensions in mm							Weight in kg	
			\dot{V} [L/s] $\Delta T=-16$ K	\dot{V} [L/s] $\Delta T=-12$ K	\dot{V} [L/s] with perf. $\Delta T=-10$ K ³⁾	$\varnothing D_5$	H_1	H_2	D_2	$D_4^{4)}$	$\square E$	Air Outlet	Connection Box	
DN 250	\square 300 ²⁾	0	32-108	27-108	49-92	249	350	25	270	355	\square 295	1.2	3.5	
DN 355	\square 450 \square 500 \square 600 \square 24"	0	55-221	48-221	101-202	299	375	37	395	500	\square 445 \square 495 \square 595 \square 23.75"	2.0 to 3.0	4.8	
		1	48-192	42-192	81-171	299	375							
		2	40-158	35-158	72-145	249	350							
		3	34-122	30-122	58-116	249	350							
		4	23-90	20-90	42-84	199	325							
		5	16-62	14-62	28-56	199	325							
DN 500	\square 600 \square 24"	6	12-44	10-44	22-40	149	300	52	560	710	\square 595 \square 23.75"	2.7 to 3.6	7.4	
		0	110-439	96-439	-	399	425							
		1	99-389	86-389	-	399	425							
		2	92-354	80-354	-	399	425							
		3	75-292	65-292	-	349	400							
		4	57-218	50-218	-	299	375							
5	39-151	34-151	-	249	350									

1) V_{max} based on 35 Pa maximum Total Pressure.

2) Larger sizes available on request.

3) Perforated face adds 3 dB and increases pressure loss by 10%.

4) Required for freely suspended applications.

Products supplied may differ slightly from those described in this technical brochure due to on-going product development.

NOTES TO NOMOGRAMS ON PAGES 5 & 7

Comments / Nomogram valid for:

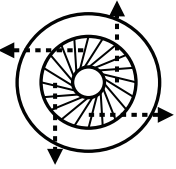

- 1 360° discharge pattern (4-way blow).

Adjustments:

For 270° discharge (3-way blow):
Multiply actual airflow rate by 1.33 to determine performance from nomogram.

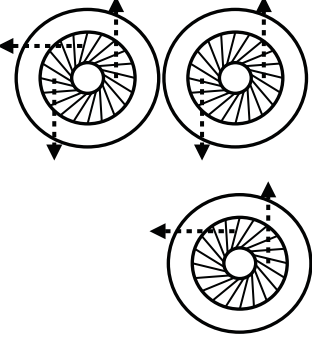

For 180° or 2 x 90° discharge (2-way blow):
Multiply actual airflow rate by 2 to determine performance from nomogram.

- 2 ΔT +ve denotes heating.
Heating valid for 100% high-level return.

For low-level return:
 $\Delta T_{\text{max,heating}} \approx (1 + (\text{LRA}\%)/100) \bullet \Delta T_{\text{max}}$, where LRA% = % low level return.

Valid for discharge from closed ceiling.



For freely-suspended diffuser:

Heating $\Delta T_{\text{max,freely suspended}} \approx \Delta T_{\text{max,heating}} / 1.2$



- 3 Total pressure (P_t) is inclusive of side-entry connection box pressure loss.

- 5 For height ≤ 2.7 m select 2.7; otherwise select height twice (once in the grey zone; once in the white zone).

- 6 ΔT -ve denotes cooling.

Minimum spacing between two diffusers (C_{min}) is to be halved for spacing to walls or glazing.

- 7 ΔT -ve denotes cooling. Maximum spacing between two diffusers (C_{max}) is to be halved for spacing to walls or glazing. Determine C_{max} twice (once based on cooling ΔT ; once based on discharge height), then select the lower of the two outputs.

- 8 Select desired comfort level to determine minimum and maximum spacing (C_{min} & C_{max}) and minimum discharge height (H_{min}).

H_{min} for discharge from closed ceiling.



For freely-suspended diffuser:

$H_{\text{min,freely suspended}} \approx H_{\text{min}} \bullet 1.1$



- 9 Sound pressure level L_P [NC] is valid per diffuser in a standard commercial office only with a 2.7 m to 3 m ceiling. L_P should not be used for spaces other than offices, but should, instead be calculated by an acoustical engineer.

Thermal Comfort Guide:

ADPI $\geq 95\%$: **Premium comfort** sedentary activity, such as in auditoria.

ADPI $\geq 90\%$: **High comfort** near-sedentary activity, such as in board rooms, high end offices and libraries.

ADPI $\geq 80\%$: **Good comfort** near-sedentary activity, such as in open-plan offices and meeting rooms.

ADPI $\geq 70\%$: **Standard comfort** medium activity, such as in transient spaces, retail and lobbies.

Quick selection guide. Refer to the online selection tool for

HSC-FD-DN250 & DN355-R0 to R6

DN250 - - - - -
DN355 ———

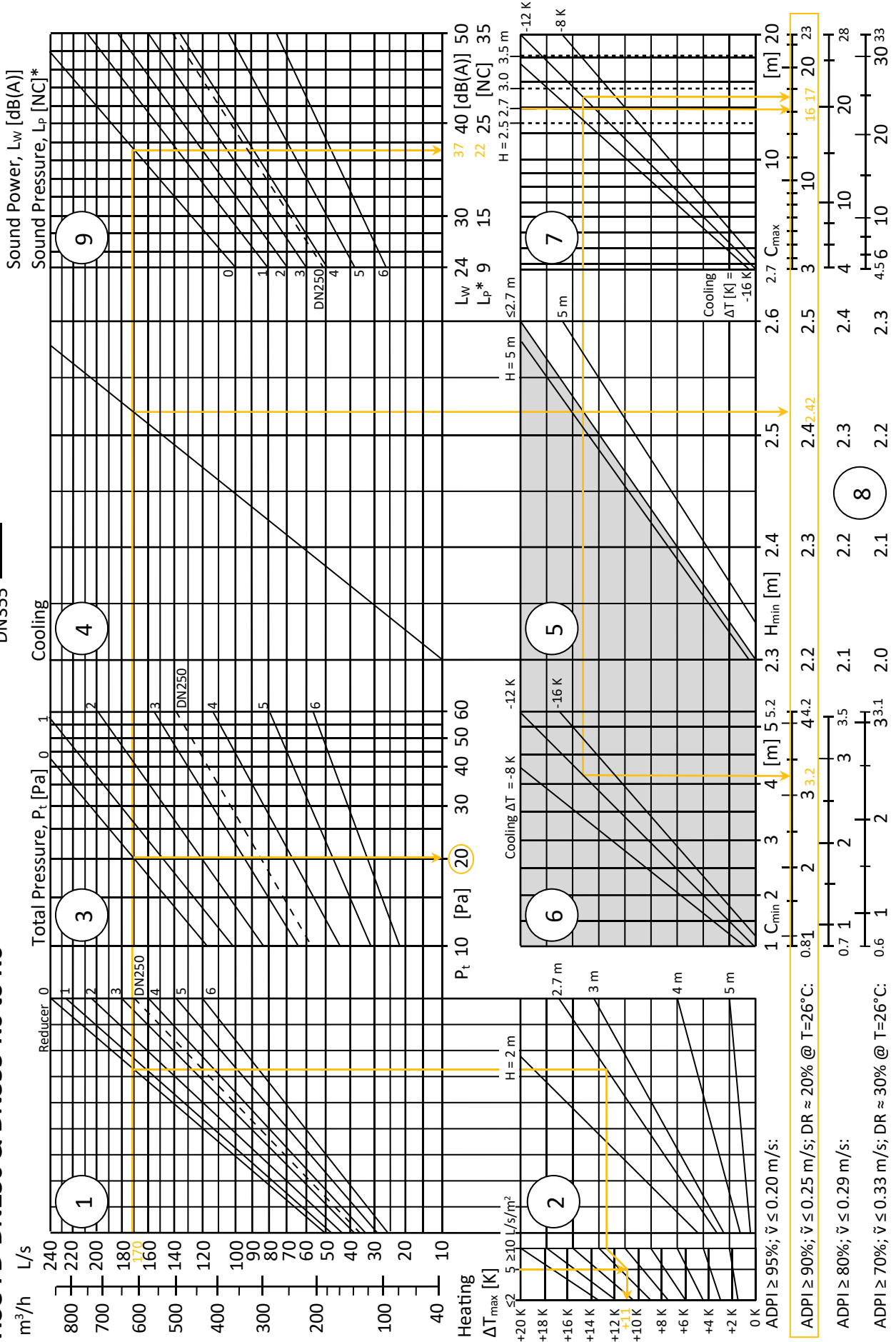

REFER TO NOTES ON PAGE 4

Notes:
* Based on 10 dB room absorption.

EXAMPLE: HSC-FD-DN355-3w in an office

Determine the performance parameters of an HSC-FD-DN355 with no reducer operating at 128 L/s and incorporating a blanking segment to produce a 270° discharge pattern (3-way blow) from a 2.7 m high closed ceiling, supplying 5 L/s/m² to a premium office with 100% high-level return air. The supply-to-room temperature differential when cooling is -12 K.

- 1 Due to the 270° discharge pattern, multiply the actual airflow rate of 120 L/s by 1.33, providing 170 L/s for input into the nomogram. Select no collar (Reducer 0).
- 2 Select 2.7 m discharge height and 5 L/s/m² specific airflow, resulting in a maximum heating temperature differential (ΔT_{\max}) of +11 K.
- 3 The total pressure (P_t) is 20 Pa, inclusive of side-entry connection box pressure loss.
- 5 Select 2.7 m discharge height, which is common to both the grey zone and the white zone.
- 6 Select -12 K cooling.
- 7 Select -12 K cooling and 2.7 m discharge height.
- 8 For a premium office, select ADPI = 90%. The minimum recommended centre-line distance (C_{\min}) between two adjacent diffusers is 3.2 m; and hence 1.6 m to walls that the diffuser discharges towards. The minimum recommended discharge height (H_{\min}) is 2.42 m. The maximum recommended centre-line distance (C_{\max}) is 16 m (ie the lower of 16 m for 2.7 m discharge height and 17 m for -12 K cooling); and hence 8 m to walls that the diffuser discharges towards.
- 9 The A-weighted sound power level (L_w) of the diffuser is 37 dB(A), producing a sound pressure level (L_p) of NC 22 in the space (based on 10 dB room absorption).

Quick selection guide. Refer to the online selection tool for

HSC-FD-DN500

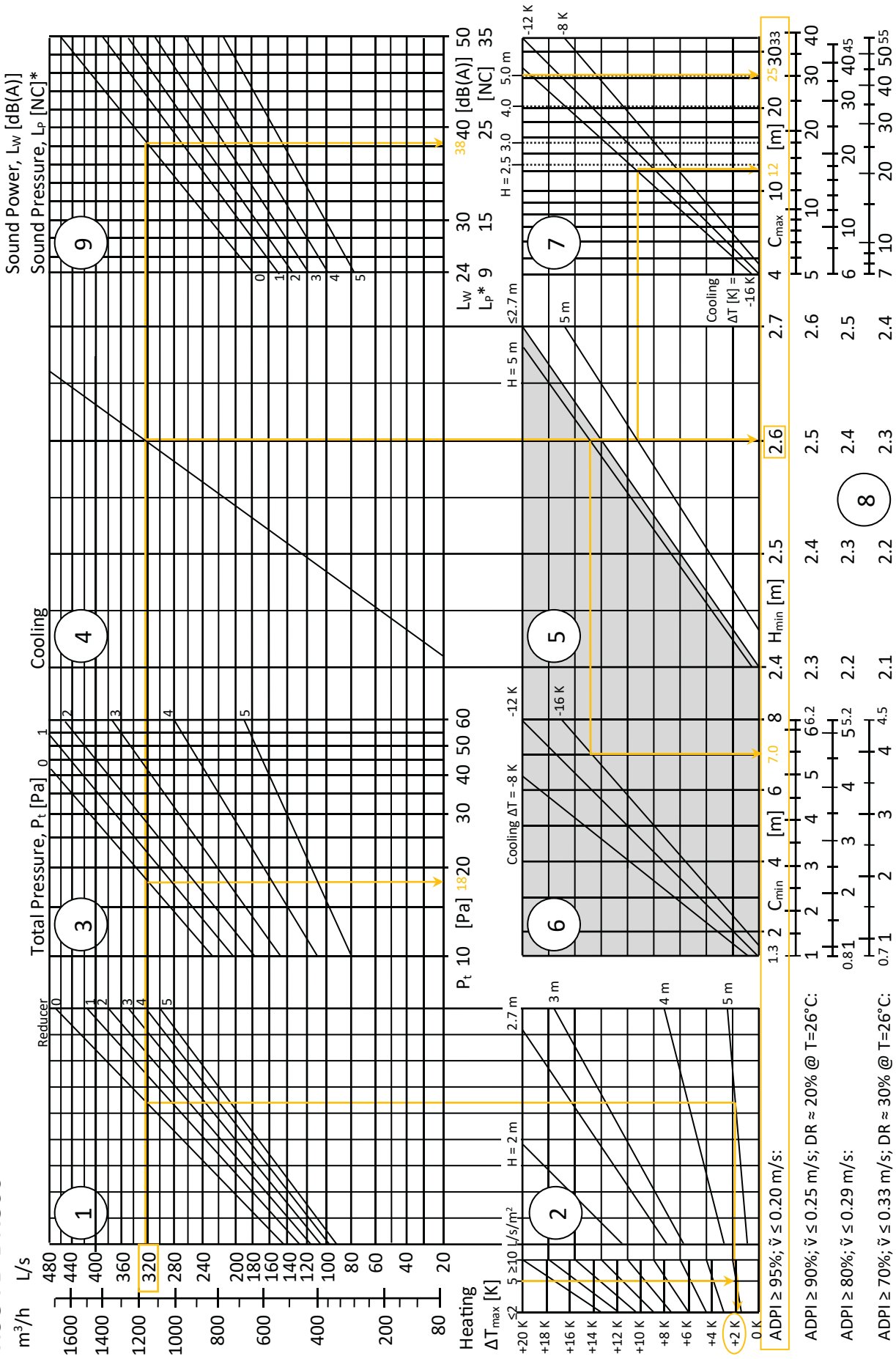

REFER TO NOTES ON PAGE 4

EXAMPLE: HSC-FD-DN500 in an auditorium

Determine the performance parameters of HSC-FD-DN500 diffusers with no reducer, each freely suspended at 5 m height and discharging 320 L/s, supplying 5 L/s/m² to an auditorium with 100% high level return air. The supply-to-room temperature differential when cooling is -16 K.

- 1 Select 360 L/s for input into the nomogram.
Select no collar (Reducer 0).
- 2 Select 5 m discharge height and 5 L/s/m² specific airflow, resulting in a maximum heating temperature differential (ΔT_{max}) of +2 K. As the diffuser is freely suspended, $\Delta T_{\text{max, freely suspended}} \approx \Delta T_{\text{max, heating}} / 1.2 \approx +1.7$ K, based on 100% high level return air. (Even 100% low level return air will only increase $\Delta T_{\text{max, freely suspended}}$ to +3.3 K, which is not sufficient for heating. Consider using the Smartemp HSC-AD instead if heating is required.)
- 3 The total pressure (P_t) is 18 Pa, inclusive of side-entry connection box pressure loss.
- 5 Select 5 m discharge height twice (once in the grey zone; once in the white zone).
- 6 Select -16 K cooling.
- 7 Select -16 K cooling and 5 m discharge height.
- 8 For an auditorium, select ADPI = 95%. The minimum recommended centre-line distance (C_{min}) between two adjacent diffusers is 7.0 m; and hence 3.5 m to walls. The minimum recommended discharge height (H_{min}) is 2.6 m. The maximum recommended centre-line distance (C_{max}) is 12 m (ie the lower of 12 m for -16 K cooling and 25 m for 5 m discharge height); and hence 6 m to walls.
- 9 The A-weighted sound power level (L_w) per diffuser is 38 dB(A). As this is a large volume auditorium (and not an office, which typically has approximately 10 dB room absorption) the sound pressure level (L_p) based on 10 dB room absorption should not be used (ie only L_w should be provided for acoustical calculations).

FEATURES

- $\Delta T_{\text{supply-room}} \geq -16 \text{ K}$ (cooling); $\leq +12 \text{ K}$ (heating), depending on application.
- Well suited to low temperature VAV systems with minimum $\Delta T_{\text{supply-room}} = -16 \text{ K}$ including turndown to 25%.
- Discharge height: 2.4 m to 4.5 m.
- Diffuse airflow from fixed stable horizontal swirl discharge pattern for high thermal comfort.
- 20 off-set radial vanes flush with flat diffuser face.
- Diffuser face may be square or round.
- Optional perforated screen.
- For installation substantially flush with suspended false ceiling or freely suspended.
- Vanes with cambered leading edges to reduce both noise and pressure drop.
- Helical twist vane tips for increased airflow rate range of operation.
- Available in 3 neck sizes: DN250; DN355; DN500.
- Low sound power level and pressure loss.
- Suitable for high airflow rates.
- Optional reducers for low airflow rates (DN355 and DN500 only).
- Segments covers (1/4; 2/4 opposed; 1/2) for diffuser placement near walls, in corridors or in corners.
- Diffuser made of powder coated sheet metal.
- Central optional threaded rod fastener with flush cap.
- Optional foam connection boxes, including magnetic perimeter edges and central

ORDER DETAILS

HSC-FD-DN ___ - ___ -R - ___ -P - - -

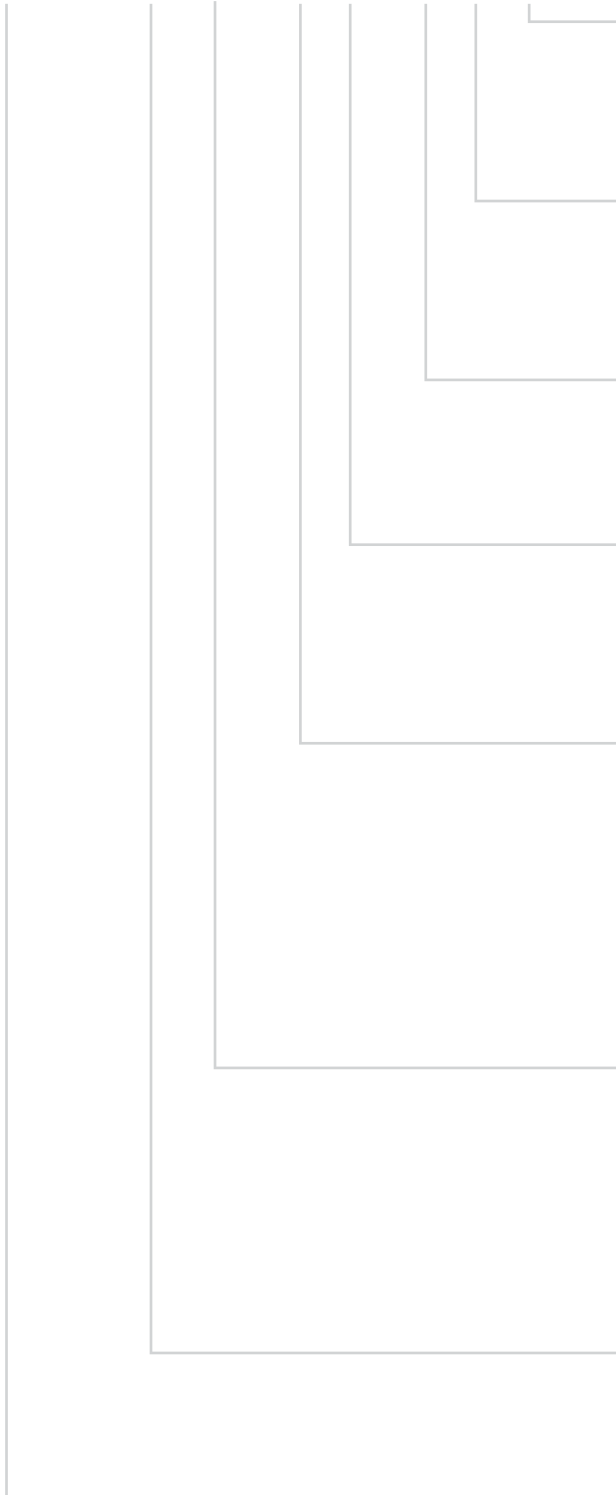

CONNECTION TYPE:

- 0* = No connection box.
- KF = Thermally insulated foam connection box with magnetic fastener & blanking cap.
- KFR = As for KF plus threaded rod fastener and cap.

SURFACE FINISH:

- 9003* = Face powder coated to RAL 9003 (Signal White).
- 9005* = Face powder coated to RAL 9005 (Jet Black).
- ____ = Face powder coated to RAL ____.

FACE FINISH:

- 0* = No perforated face.
- 1 = Perforated face (DN355 only).

DISCHARGE PATTERN:

- 4w* = No blanking segments.
- 3w = 1/4 blanking segment – for diffuser adjacent to wall.
- 2s = 2/4 blanking segments – for diffuser in corridor.
- 2a = 1/2 blanking segment – for diffuser in corner.

REDUCER:

- 0* = No reducer
- 1 – 6 = Reducers 1 to 6 for size DN355.
- 1 – 5 = Reducers 1 to 5 for size DN500.

FACE SHAPE:

- S* = Square face with 90° turn-up for coffered ceilings:
 - □ 295 mm¹ for size DN250;
 - □ 595 mm* (445 mm to 603 mm [23.75"] available) for size DN355;
 - □ 595 mm* to 603 mm [23.75"] for size DN500.
- C² = Circular face with flush contact edge (4 mm / 30°) for closed false ceilings:
 - Ø 355 mm* for size DN250;
 - Ø 500 mm* for size DN355;
 - Ø 710 mm* for size DN500.

NOMINAL DIAMETER:

- DN250 = Nominal neck diameter 250 mm.
- DN355 = Nominal neck diameter 355 mm.
- DN500 = Nominal neck diameter 500 mm.

MODEL:

- Helical Swirl Ceiling - Fixed Direction

Note:

* Standard, if no type code entered.

¹ Other face sizes available on request.

² Required for freely suspended applications.

Products supplied may differ slightly from those described in this technical brochure due to on-going product development.

Furnish and install SMARTEMP® Fixed Helical Swirl Diffusers, type HSC-FD, to provide diffuse airflow with fixed stable horizontal swirl discharge pattern for the provision of high thermal comfort. Each diffuser is to be made of powder coated steel and shall include 20 off-set radial vanes flush with the flat diffuser face. The diffuser shall be installed complete with a flush colour matching central cap and shall be suitable for central threaded rod connection. The diffuser face is to be square or round, as specified, and is to be fitted with the optional perforated screen where indicated. The diffuser is to be installed substantially flush with the suspended false ceiling or freely suspended, as specified. Swirl vanes are to include cambered leading edges for reduced noise and pressure drop, and helical swirl vane tips are each to have geometric twist to increase the airflow rate range of operation. Diffuser neck size is to be DN250, DN355 or DN500, as appropriate. Fit optional reducers where low airflow rates are required (DN355 and DN500 only). Install the diffusers at a discharge height of 2.4 to 4.5 m. For VAV applications, operate each diffuser within an airflow rate band turning down to no less than 25% at a $\Delta T_{\text{supply-room}} \geq -16$ K. For heating applications, observe $\Delta T_{\text{supply-room}}$ recommendations. Install segment covers (1/4; 2/4 opposed; 1/2) for diffuser placement near walls, in corridors or in corners. Connect each diffuser to SMARTEMP foam connections boxes, suitable for perimeter magnetic and/or central threaded rod connections, as specified.



For additional information, please contact info@smartemp.com

We strive to continually improve SMARTEMP products. Brochures and marketing material are subject to change without notice and may not reflect the most recent product variants. Please contact us or consult your SMARTEMP sales representative for current specifications or more detailed information. Not all products may be available in all geographic regions.

Applicable Patents and Trade Marks can be viewed at smartemp.com/patents

Not to be reproduced, wholly or in part, without the written permission of SMARTAIR DIFFUSION Pty. Ltd.

® SMARTEMP is a registered trade mark. © 2024.