



## Air Cooled Packaged Unit Technical Data

---

OPA 336 Eco Ultra

---

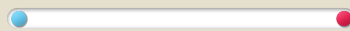

Cooling Capacity  
17.6-33.6 kW

Heating Capacity  
14.0-28.9 kW

# Air Cooled Packaged Units

## Contents



<b>OPA 336 ECO ULTRA</b>	<b>3</b>	<b>PERFORMANCE DATA</b>	<b>7</b>
General	3	Cooling Capacity (kW)	7
Applications	4	Heating Capacity (kW)	10
Air Flow Selection	4	Air Handling	11
Features	4	Indoor Air Flow Correction Factors @ nominal conditions	11
Refrigerant R410A	4	Sound Levels	12
Efficiency	4	Sound Power Levels (SWL) - Radiated	12
Performance	4	Sound Pressure Levels (SPL)	12
Quiet	4	Sound Power Levels (SWL) - Supply Air Outlet	12
Insulation	5		
Durable	5	<b>DIMENSIONS (mm)</b>	<b>13</b>
Easy Access	5		
Lower Maintenance	5	<b>SPECIFICATIONS</b>	<b>15</b>
Soft Starting	5		
Control Options	5		
Extended Capability	5		
Self Diagnostics	5		
Safety Features	6		
Refrigeration System	6		
Wiring	6		
Economiser Option	6		
Configurations	6		
Optional Equipment	6		

# Air Cooled Packaged Units

## OPA 336 Eco Ultra



These Eco Ultra Packaged rooftop HVAC units provide the ultimate flexibility and performance demanded in open plan commercial environments. Key benefits are energy efficiency, noise isolation from occupied areas, ease of fresh air integration, and the reliability and durability inherent in a factory assembled packaged system. The OPA 336 efficiently delivers controlled indoor environments from  $-15^{\circ}\text{C}$  to  $+52^{\circ}\text{C}$  ambient conditions.

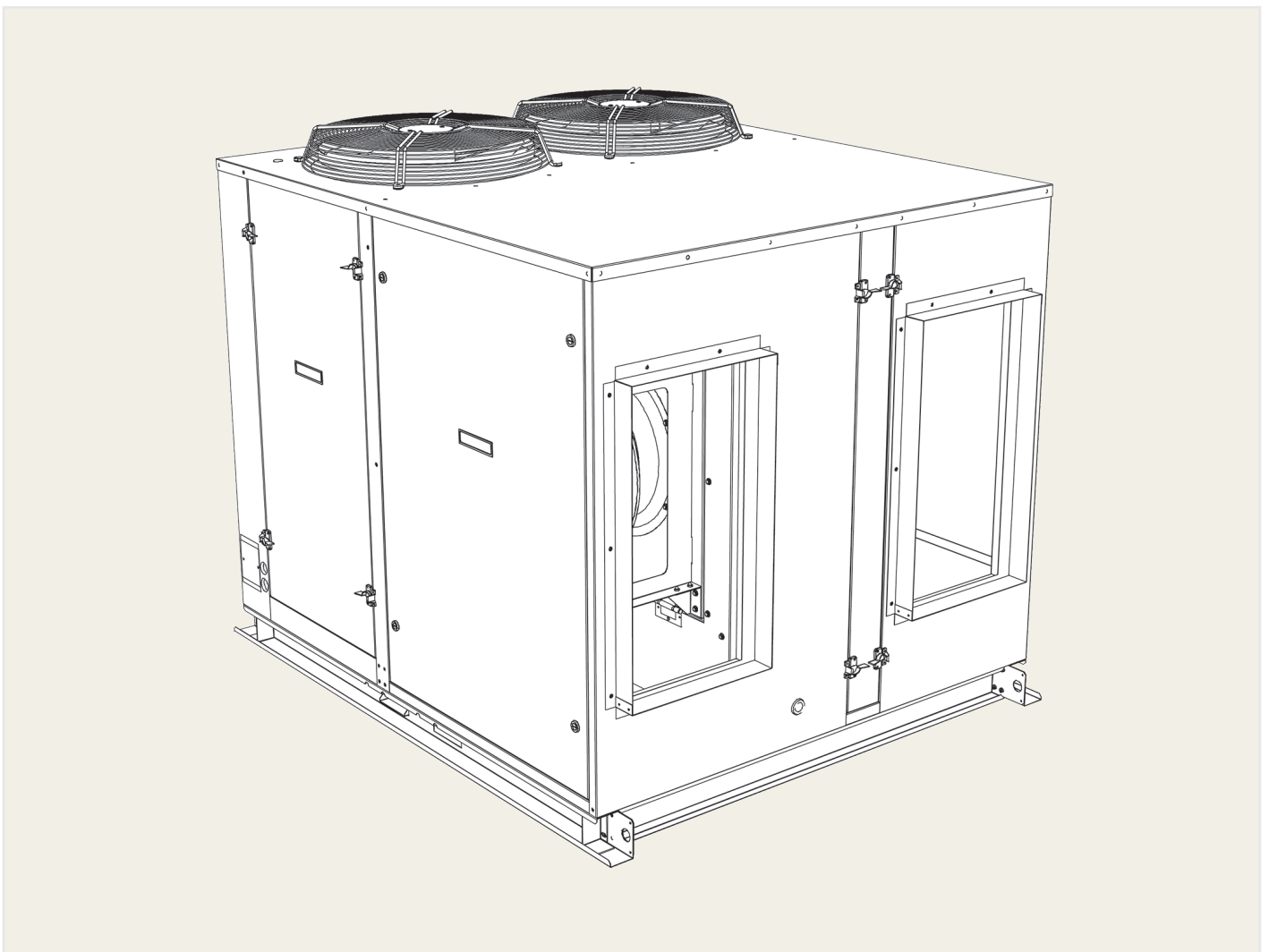

# Air Cooled Packaged Units

## OPA 336 Eco Ultra



### Applications

Specifically developed for commercial premises i.e. banks, offices, motels/ hotels, restaurants and retail outlets.

Suitable for applications using full or high proportions of fresh air (Note: pre-heating on heating cycle may be required). Also suitable for VAV, close control and supply air temperature control.

### AIR FLOW SELECTION

If air returning to the indoor coil is regularly expected to be above 50% relative humidity then the coil face velocity should not exceed 2.5m/s (refer air flow graph page 8)

Consideration must be given to selecting an airflow and coil face velocity that avoids water carry - over problems i.e. in high humidity (tropical/subtropical) conditions or when heavily moisture laden fresh air is introduced. Applications using complete or high proportion of fresh air should be discussed with a Temperzone sales engineer to establish the correct selection of unit

### FEATURES

#### Refrigerant R410A

R410A used which has zero ozone depletion potential

#### Economy

An economiser option is available to lower operating costs during the cooling cycle. Each unit has an inverter compressor which uses less energy than alternative types of compressor during normal operation.

#### Efficient

Each unit incorporates an inverter scroll compressor which is very efficient at part load. Part load efficiency can be even further enhanced by indoor fan part load operation at low loads (75% airflow equates to 55% power use). Each plug fan incorporates a high efficiency electronically commutated (EC) motor (up to 90% efficiency; significantly better than belt drive centrifugal fans). Heat exchange coils incorporate inner grooved (rifled) tube for better heat transfer.

#### Performance

The inverter technology can provide close comfort control of the room temperature. Additional capacity above the nominal figure is available if necessary.

The OPA also uses a backward curved plug fan for fine tuning of the indoor air to match higher static pressure supply air requirements. These EC motor fans have a fully integrated speed control that enables soft starting. Fan speed can be stepped to your own requirements or continuously variable using a 0-10V DC control signal. Electronic expansion valves (EEV) assist in optimising refrigerant flow. The system includes a digital temperature sensing head pressure control (via pressure transducers) which enables the system to compensate for outdoor ambient temperatures below 20°C on cooling cycle, and above 15°C on heating cycle.

Having no belts, EC plug fans are ideal for restaurant type applications as they don't introduce wear particles into the air flow as belt drive fans can.

# Air Cooled Packaged Units

## OPA 336 Eco Ultra



### FEATURES (CONT'D)

#### Quiet

Each EC plug fan can vary from zero to full speed. This allows slow ramp up with no sudden noise change. The motor can be controlled to have the best air flow for the ducting and requirements as well as used for de-humidifying the space. A large supply air spigot reduces exit velocities and therefore less noise is transferred into the ductwork. Generous use of insulation also ensures a quiet unit.

#### Insulation

Closed cell foam insulation has been used in the indoor air section to ensure no particles are introduced into the air stream. The insulation is foil faced and meets fire test standards AS 1530.3 (1989) and BS 476 parts 6 & 7.

#### Durable

The cabinet is constructed from high grade galvanised steel - polyester powder coated (colour Grey) for all weather protection. External fasteners are marine grade steel. The units include a polyester powder coated drain tray. Heat exchange coils comprise aluminium corrugated plate fins on mechanically expanded rifled copper tube. Both the indoor and outdoor air coil fins are epoxy coated for extra protection in corrosive environments, e.g. salt laden sea air. Fan motor bearings are sealed for life so as not to incur regular maintenance. Coil protection guards protect against hail, accidental damage or vandalism

#### Easy Access

These packaged outdoor units are typically installed on a rooftop, where maintenance access is relatively easy during operating hours.

#### Low Maintenance.

Commissioning and maintenance costs are reduced through use of a fan that requires no pulley and belt adjustments or changes like traditional fans.

#### Soft Starting

Inverter compressor and EC motors are soft starting therefore have none of the problems associated with high in-rush current.

#### Control Option

Commissioned air flow can be maintained through use of a differential pressure transducer and controller (supplied by others) to compensate for varying duct static pressures caused by dirty filters or modulating dampers. Commissioning is also made easier. The EC plug motor is controlled variably by a 0–10 volt DC signal supplied by, or via, the unit's UC8 Controller. The compressor to be controlled variably by a 0–10 volt DC signal that can be supplied either by a BMS system, a sophisticated controller or temperzone's optional TZZ-100 Controller. This unit's UC8 controller is BMS compatible with multi-unit control possible – either via digital and analogue signals or via Modbus/RTU. BACnet/IP is also an option.

#### Extended Capability

Inverters are particularly suitable for applications requiring full or high proportions of fresh air, VAV, close control. Supply air temperature control is also possible using BMS or other controls. Refer to Temperzone for capacity range variation options.

#### Self Diagnostics

The OPA's Unit Controller (UC8) has a 7 segment LED display to indicate faults and running conditions. Many operating status conditions can be determined, without gauges, simply by using this display. A common fault indicator is included for interface to external systems.

# Air Cooled Packaged Units

## OPA 336 Eco Ultra



### SAFETY FEATURES

1. HP and loss of refrigerant protection
2. Anti rapid cycle timer and internal overload for compressor protection
3. Circuit breaker protected control circuits
4. Automatic de-ice cycle provides de-ice control during heating cycle under low ambient conditions
5. Frost protection on cooling cycle
6. Sensor fault indication
7. Crankcase heater prevents liquid refrigerant condensing in the compressors during the "off" cycle
8. Compressor minimum run time to ensure oil return
9. 24V control circuit

### REFRIGERATION SYSTEM

The high efficiency inverter scroll type compressor is hermetically sealed quiet running and supported on rubber mounts to minimize vibration

Factory charged with HFC-410A (R410A) refrigerant. Electronic expansion devices are used for precise control of the flow of refrigerant over a wide range of conditions.

### WIRING

The electrical supply required is 3 phase 400V ac 50Hz with neutral & earth

The compressor crankcase heater requires a 24hr power supply

The unit's control panel is fully wired ready to accept the main power supply. Each system conforms with emission standards EN 55014-1, EN 60335-1 and EN 60335-2-40.

### ECONOMISER OPTION

(Controls by others)

If the outdoor air heat content or wet bulb temperature (dry bulb not recommended) is below that of the return air, the fresh air damper opens and the return air damper closes to provide the first stage of cooling. Operating costs are reduced as free cooling is obtained. (Note: A spill air facility in the building may be necessary for when the return air damper is closed.) Fresh air dampers close to a minimum setting and return air dampers open before normal compressor operation resumes.

Temperzone offers a factory fitted Economiser control package, if required.

### CONFIGURATIONS

1. Horizontal supply & return air versions
2. Downward supply & return air versions
3. Opposite hand versions of the above.

### OPTIONAL EQUIPMENT

1. TZT-100 room temperature controller.
2. Filters (G4) rated to AS1324.1.2001 - disposable or washable.
3. Factory fitted economiser -includes dampers, fresh air cowl.
4. Electronic control systems (available by arrangement) for temperature and economy cycle.
5. Factory fitted adjustable fresh air damper and cowl.
6. High static condenser fans for situations where there is external resistance from ducting the outside air, eg plant rooms.
7. Interface to BACnet/IP networks.

# ECO ULTRA Performance Data

## COOLING CAPACITY (KW)

TC = Total Capacity (kW).

SC = Sensible Cooling Capacity (kW).

PI = Power Input (kW)

E.A.T. = Entering Air Temperature .

○ = Nominal Capacity (kW) @ load specified

Nominal Air Flow: **1700 l/s**

**Note:** Total Capacity figures are **gross** and do not include allowance for fan motor heat loss.

### OPA 336 ECO ULTRA @100% (1700 l/s)

Indoor coil E.A.T.

Outdoor coil entering air temperature °C D.B.

D.B. °C	W.B. °C	23			27			31			35			39			43		
		TC	SC	PI	TC	SC	PI	TC	SC	PI	TC	SC	PI	TC	SC	PI	TC	SC	PI
21	14	32.7	25.7	8.7	31.5	25.3	9.4	30.3	24.8	10.1	29.0	24.2	10.8	27.6	23.5	11.7	26.3	22.8	12.6
	15	33.9	23.7	8.8	32.6	23.3	9.4	31.3	22.8	10.1	30.0	22.2	10.9	28.6	21.5	11.8	27.2	20.8	12.7
	16	35.0	21.4	8.8	33.8	21.0	9.5	32.4	20.5	10.2	31.0	19.9	11.0	29.6	19.2	11.8	28.1	18.5	12.8
	17	36.2	18.8	8.9	34.9	18.3	9.5	33.5	17.8	10.2	32.1	17.3	11.0	30.6	16.6	11.9	29.0	16.0	12.9
23	15	33.7	27.7	8.8	32.5	27.4	9.4	31.2	26.9	10.1	29.9	26.3	10.9	28.5	25.5	11.8	27.0	24.8	12.7
	16	34.7	25.8	8.8	33.4	25.4	9.5	32.1	24.9	10.2	30.7	24.3	11.0	29.3	23.6	11.8	27.8	22.9	12.8
	17	35.9	23.8	8.9	34.6	23.4	9.5	33.2	22.9	10.2	31.8	22.3	11.0	30.3	21.6	11.9	28.8	20.8	12.9
	18	37.1	21.5	8.9	35.7	21.0	9.6	34.3	20.5	10.3	32.8	19.9	11.1	31.3	19.3	12.0	29.7	18.6	13.0
27	18	36.9	30.1	8.9	35.6	29.7	9.6	34.2	29.1	10.3	32.7	28.5	11.1	31.2	27.8	12.0	29.6	26.9	13.0
	19	38.0	28.3	8.9	36.6	27.9	9.6	35.1	27.4	10.3	33.6	26.7	11.1	32.0	26.0	12.0	30.4	25.2	13.0
	20	39.1	26.3	9.0	37.6	25.9	9.6	36.1	25.3	10.4	34.6	24.7	11.2	32.9	24.0	12.1	31.3	23.2	13.1
	22	41.3	21.5	9.1	39.8	21.1	9.7	38.2	20.5	10.5	36.5	19.9	11.3	34.8	19.2	12.3	33.0	18.5	13.3
31	21	40.5	32.6	9.0	39.1	32.2	9.7	37.5	31.6	10.5	35.9	30.9	11.3	34.2	30.1	12.2	32.4	29.2	13.2
	22	41.5	30.8	9.1	40.0	30.4	9.7	38.4	29.8	10.5	36.7	29.1	11.3	35.0	28.3	12.3	33.2	27.5	13.3
	23	42.4	28.8	9.1	40.9	28.3	9.8	39.2	27.8	10.5	37.5	27.1	11.4	35.8	26.4	12.3	33.9	25.5	13.3
	25	44.6	24.2	9.2	42.9	23.7	9.9	41.2	23.2	10.6	39.4	22.5	11.5	37.5	21.8	12.4	35.6	21.0	13.5

### OPA 336 ECO ULTRA @Nominal (1700 l/s)

Indoor coil E.A.T.

Outdoor coil entering air temperature °C D.B.

D.B. °C	W.B. °C	23			27			31			35			39			43		
		TC	SC	PI	TC	SC	PI	TC	SC	PI	TC	SC	PI	TC	SC	PI	TC	SC	PI
21	14	27.9	24.9	6.7	27.6	24.9	7.2	26.8	24.4	7.7	25.5	23.7	8.3	23.8	22.5	8.9	21.8	20.8	9.7
	15	28.9	23.1	6.8	28.5	23.1	7.2	27.7	22.6	7.7	26.4	21.9	8.3	24.6	20.7	9.0	22.5	19.1	9.7
	16	29.9	21.1	6.8	29.5	21.0	7.2	28.6	20.4	7.8	27.2	19.8	8.4	25.5	18.7	9.0	23.3	17.2	9.8
	17	30.9	18.7	6.8	30.4	18.6	7.3	29.6	18.1	7.8	28.1	17.4	8.4	26.3	16.4	9.1	24.0	15.0	9.8
23	15	28.6	26.0	6.7	28.3	26.1	7.2	27.6	25.9	7.7	26.2	25.0	8.3	24.7	23.7	9.0	22.6	21.6	9.7
	16	29.5	24.4	6.8	29.1	24.4	7.2	28.4	24.2	7.8	27.0	23.3	8.4	25.4	22.3	9.0	23.2	20.6	9.8
	17	30.4	22.6	6.8	30.1	22.6	7.3	29.3	22.3	7.8	27.9	21.5	8.4	26.3	20.5	9.1	24.0	18.9	9.8
	18	31.5	20.6	6.8	31.1	20.5	7.3	30.3	20.2	7.8	28.8	19.4	8.4	27.2	18.5	9.1	24.8	17.0	9.9
27	18	31.0	27.5	6.8	30.7	27.4	7.3	30.0	27.1	7.8	28.5	26.3	8.4	27.0	25.0	9.1	24.8	23.4	9.9
	19	31.9	26.0	6.8	31.6	25.9	7.3	30.8	25.6	7.9	29.3	24.8	8.5	27.8	23.5	9.2	25.5	22.0	9.9
	20	32.8	24.3	6.8	32.5	24.2	7.3	31.7	23.9	7.9	30.1	23.1	8.5	28.5	21.9	9.2	26.2	20.4	10.0
	22	34.6	20.3	6.9	34.3	20.1	7.4	33.4	19.7	7.9	31.7	19.0	8.6	30.1	17.9	9.3	27.6	16.6	10.1
31	21	33.6	30.7	6.9	33.2	30.7	7.4	32.3	30.3	7.9	31.1	29.4	8.6	29.3	28.1	9.3	27.2	26.3	10.0
	22	34.4	29.1	6.9	34.0	29.2	7.4	33.0	28.7	7.9	31.8	27.8	8.6	30.0	26.6	9.3	27.8	24.8	10.1
	23	35.2	27.4	6.9	34.7	27.4	7.4	33.8	26.9	8.0	32.6	26.0	8.6	30.6	24.9	9.3	28.4	23.2	10.1
	25	36.9	23.4	6.9	36.4	23.3	7.4	35.4	22.9	8.0	34.2	22.0	8.7	32.1	20.9	9.4	29.8	19.4	10.2

# ECO ULTRA Performance Data at part load

## COOLING CAPACITY (KW)

TC = Total Capacity (kW).

SC = Sensible Cooling Capacity (kW).

PI = Power Input (kW)

E.A.T. = Entering Air Temperature .

○ = Nominal Capacity (kW) @ load specified

Nominal Air Flow: **1700 l/s**

**Note:** Total Capacity figures are **gross** and do not include allowance motor heat loss.

### OPA 336 ECO ULTRA @Nominal -10% (1700 l/s)

Indoor coil E.A.T.

Outdoor coil entering air temperature °C D.B.

D.B. °C	W.B. °C	23			27			31			35			39			43		
		TC	SC	PI	TC	SC	PI	TC	SC	PI	TC	SC	PI	TC	SC	PI	TC	SC	PI
21	14	25.4	22.3	5.7	24.6	22.0	6.1	23.7	21.6	6.5	22.8	21.2	7.0	21.9	20.7	7.6	20.9	19.9	8.2
	15	26.3	20.8	5.7	25.4	20.5	6.1	24.5	20.1	6.6	23.6	19.6	7.1	22.6	19.1	7.6	21.6	18.5	8.2
	16	27.2	19.1	5.8	26.3	18.7	6.2	25.4	18.3	6.6	24.4	17.9	7.1	23.4	17.4	7.6	22.3	16.8	8.3
	17	28.1	17.1	5.8	27.2	16.8	6.2	26.2	16.4	6.6	25.2	15.9	7.1	24.1	15.4	7.7	23.0	14.8	8.3
23	15	26.1	23.9	5.7	25.3	23.7	6.1	24.4	23.3	6.6	23.5	22.5	7.1	22.5	21.5	7.6	21.5	20.5	8.2
	16	26.9	22.5	5.8	26.0	22.2	6.1	25.1	21.8	6.6	24.2	21.4	7.1	23.2	20.8	7.6	22.1	20.2	8.2
	17	27.8	21.0	5.8	26.9	20.7	6.2	26.0	20.3	6.6	25.0	19.8	7.1	23.9	19.3	7.7	22.8	18.6	8.3
	18	28.7	19.3	5.8	27.8	18.9	6.2	26.8	18.5	6.6	25.8	18.0	7.1	24.7	17.5	7.7	23.6	16.9	8.3
27	18	28.6	25.9	5.8	27.7	25.6	6.2	26.7	25.2	6.6	25.7	24.7	7.1	24.6	23.6	7.7	23.4	22.5	8.3
	19	29.4	24.6	5.8	28.4	24.3	6.2	27.4	23.9	6.6	26.4	23.4	7.2	25.3	22.8	7.7	24.1	22.2	8.4
	20	30.2	23.2	5.8	29.2	22.8	6.2	28.2	22.4	6.7	27.1	21.9	7.2	25.9	21.3	7.8	24.7	20.6	8.4
	22	31.9	19.6	5.8	30.8	19.2	6.2	29.7	18.8	6.7	28.6	18.3	7.2	27.4	17.7	7.8	26.1	17.1	8.5
31	21	31.3	28.1	5.8	30.3	27.8	6.2	29.2	27.4	6.7	28.1	26.8	7.2	26.9	25.9	7.8	25.6	24.7	8.4
	22	32.0	26.8	5.8	31.0	26.4	6.2	29.9	26.0	6.7	28.7	25.5	7.2	27.5	24.9	7.8	26.2	24.1	8.5
	23	32.7	25.3	5.8	31.7	24.9	6.2	30.5	24.5	6.7	29.3	24.0	7.2	28.1	23.3	7.8	26.8	22.6	8.5
	25	34.3	21.9	5.8	33.2	21.5	6.2	32.0	21.0	6.7	30.8	20.5	7.3	29.5	19.9	7.9	28.1	19.2	8.5

### OPA 336 ECO ULTRA @Nominal -20% (1700 l/s)

Indoor coil E.A.T.

Outdoor coil entering air temperature °C D.B.

D.B. °C	W.B. °C	23			27			31			35			39			43		
		TC	SC	PI	TC	SC	PI	TC	SC	PI	TC	SC	PI	TC	SC	PI	TC	SC	PI
21	14	22.6	20.6	5.0	21.9	20.4	5.3	21.2	20.0	5.7	20.4	19.4	6.1	19.6	18.6	6.5	18.7	17.7	7.0
	15	23.3	19.3	5.0	22.6	19.1	5.3	21.9	18.7	5.7	21.1	18.3	6.1	20.2	17.8	6.5	19.3	17.3	7.1
	16	24.1	17.8	5.0	23.4	17.5	5.3	22.6	17.2	5.7	21.7	16.7	6.1	20.9	16.3	6.6	19.9	15.7	7.1
	17	24.9	16.1	5.0	24.1	15.8	5.3	23.3	15.4	5.7	22.4	15.0	6.1	21.5	14.5	6.6	20.6	14.0	7.1
23	15	23.2	22.1	5.0	22.5	21.5	5.3	21.8	20.8	5.7	21.0	20.0	6.1	20.1	19.1	6.5	19.2	18.2	7.0
	16	23.9	20.9	5.0	23.1	20.6	5.3	22.4	20.3	5.7	21.5	19.8	6.1	20.7	19.4	6.6	19.8	18.8	7.1
	17	24.7	19.6	5.0	23.9	19.3	5.3	23.1	18.9	5.7	22.2	18.5	6.1	21.3	18.0	6.6	20.4	17.4	7.1
	18	25.5	18.1	5.0	24.7	17.7	5.3	23.8	17.4	5.7	23.0	16.9	6.1	22.0	16.4	6.6	21.1	15.9	7.1
27	18	25.4	24.0	5.0	24.6	23.6	5.3	23.7	22.8	5.7	22.9	21.9	6.1	21.9	21.0	6.6	21.0	20.0	7.1
	19	26.1	22.8	5.0	25.2	22.5	5.3	24.4	22.2	5.7	23.5	21.7	6.1	22.5	21.2	6.6	21.5	20.6	7.2
	20	26.8	21.5	5.0	25.9	21.2	5.3	25.1	20.8	5.7	24.1	20.4	6.1	23.1	19.9	6.6	22.1	19.3	7.2
	22	28.2	18.5	5.0	27.3	18.1	5.3	26.4	17.7	5.7	25.4	17.2	6.2	24.4	16.7	6.7	23.3	16.1	7.2
31	21	27.7	26.0	5.0	26.9	25.7	5.3	26.0	25.0	5.7	25.0	24.0	6.2	24.0	23.0	6.7	22.9	21.9	7.2
	22	28.4	24.8	5.0	27.5	24.5	5.3	26.5	24.1	5.7	25.5	23.6	6.2	24.5	23.1	6.7	23.4	22.4	7.2
	23	29.0	23.5	5.0	28.1	23.2	5.3	27.1	22.8	5.7	26.1	22.3	6.2	25.0	21.7	6.7	23.9	21.1	7.2
	25	30.4	20.6	5.0	29.4	20.2	5.3	28.4	19.8	5.7	27.4	19.3	6.2	26.2	18.7	6.7	25.1	18.1	7.3



# ECO ULTRA Performance Data at part load

## COOLING CAPACITY (KW)

TC = Total Capacity (kW).

SC = Sensible Cooling Capacity (kW).

PI = Power Input (kW)

E.A.T. = Entering Air Temperature .

○ = Nominal Capacity (kW) @ load specified

Nominal Air Flow: **1700 l/s**

**Note:** Total Capacity figures are **gross** and do not include allowance motor heat loss.

### OPA 336 ECO ULTRA @Nominal -30% (1700 l/s)

Indoor coil E.A.T.

Outdoor coil entering air temperature °C D.B.

D.B. °C	W.B. °C	23			27			31			35			39			43		
		TC	SC	PI	TC	SC	PI	TC	SC	PI	TC	SC	PI	TC	SC	PI	TC	SC	PI
21	14	19.7	18.5	4.2	19.1	18.1	4.5	18.5	17.5	4.8	17.8	16.8	5.1	17.1	16.1	5.5	16.4	15.4	5.9
	15	20.3	17.4	4.2	19.7	17.1	4.5	19.1	16.8	4.8	18.4	16.5	5.1	17.7	16.1	5.5	16.9	15.6	5.9
	16	21.0	16.1	4.2	20.4	15.8	4.5	19.7	15.5	4.8	19.0	15.1	5.1	18.3	14.7	5.5	17.5	14.2	5.9
	17	21.7	14.6	4.2	21.0	14.3	4.5	20.3	14.0	4.8	19.6	13.6	5.1	18.8	13.2	5.5	18.0	12.7	6.0
23	15	20.2	19.2	4.2	19.6	18.6	4.5	19.0	18.0	4.8	18.3	17.3	5.1	17.6	16.6	5.5	16.9	15.9	5.9
	16	20.8	18.7	4.2	20.2	18.5	4.5	19.5	18.2	4.8	18.8	17.8	5.1	18.1	17.1	5.5	17.3	16.3	5.9
	17	21.5	17.6	4.2	20.8	17.3	4.5	20.1	17.0	4.8	19.4	16.7	5.1	18.7	16.2	5.5	17.9	15.7	6.0
	18	22.1	16.3	4.2	21.5	16.0	4.5	20.8	15.7	4.8	20.0	15.3	5.1	19.3	14.9	5.5	18.4	14.4	6.0
27	18	22.0	21.1	4.2	21.4	20.4	4.5	20.7	19.7	4.8	20.0	19.0	5.1	19.2	18.2	5.5	18.4	17.4	6.0
	19	22.6	20.5	4.2	22.0	20.2	4.5	21.3	19.9	4.8	20.5	19.5	5.2	19.7	18.7	5.5	18.9	17.9	6.0
	20	23.3	19.4	4.2	22.6	19.1	4.5	21.8	18.8	4.8	21.0	18.4	5.2	20.2	17.9	5.6	19.4	17.4	6.0
	22	24.5	16.7	4.2	23.8	16.4	4.5	23.0	16.0	4.8	22.2	15.6	5.2	21.3	15.1	5.6	20.4	14.6	6.0
31	21	24.1	23.1	4.2	23.4	22.4	4.5	22.6	21.6	4.8	21.8	20.8	5.2	20.9	20.0	5.6	20.0	19.1	6.0
	22	24.6	22.2	4.2	23.9	22.0	4.5	23.1	21.6	4.8	22.3	21.2	5.2	21.4	20.4	5.6	20.5	19.5	6.0
	23	25.2	21.1	4.2	24.4	20.8	4.5	23.6	20.5	4.8	22.8	20.1	5.2	21.9	19.6	5.6	20.9	19.0	6.0
	25	26.4	18.6	4.2	25.6	18.3	4.5	24.7	17.9	4.8	23.8	17.4	5.2	22.9	17.0	5.6	21.9	16.4	6.0

### OPA 336 ECO ULTRA @Nominal -40% (1700 l/s)

Indoor coil E.A.T.

Outdoor coil entering air temperature °C D.B.

D.B. °C	W.B. °C	23			27			31			35			39			43		
		TC	SC	PI	TC	SC	PI	TC	SC	PI	TC	SC	PI	TC	SC	PI	TC	SC	PI
21	14	16.8	15.7	3.6	16.4	15.4	3.8	15.9	14.9	4.1	15.3	14.3	4.3	14.7	13.8	4.6	14.1	13.2	5.0
	15	17.4	14.7	3.6	16.9	14.6	3.8	16.4	14.3	4.1	15.8	14.0	4.3	15.2	13.7	4.6	14.6	13.3	5.0
	16	18.0	13.6	3.6	17.4	13.4	3.8	16.9	13.2	4.1	16.3	12.9	4.3	15.7	12.5	4.6	15.1	12.1	5.0
	17	18.5	12.4	3.6	18.0	12.1	3.8	17.4	11.9	4.1	16.8	11.6	4.3	16.2	11.2	4.6	15.5	10.8	5.0
23	15	17.3	16.3	3.6	16.8	15.8	3.8	16.3	15.3	4.1	15.7	14.8	4.3	15.2	14.2	4.6	14.5	13.6	5.0
	16	17.8	15.9	3.6	17.3	15.7	3.8	16.7	15.5	4.1	16.2	15.2	4.3	15.6	14.6	4.6	14.9	14.0	5.0
	17	18.4	14.9	3.6	17.8	14.7	3.8	17.3	14.5	4.1	16.7	14.2	4.3	16.1	13.8	4.6	15.4	13.4	5.0
	18	18.9	13.8	3.6	18.4	13.6	3.8	17.8	13.3	4.1	17.2	13.0	4.3	16.6	12.6	4.6	15.9	12.3	5.0
27	18	18.9	17.9	3.6	18.3	17.3	3.8	17.7	16.8	4.1	17.1	16.1	4.3	16.5	15.5	4.6	15.8	14.8	5.0
	19	19.4	17.4	3.6	18.8	17.2	3.8	18.2	16.9	4.1	17.6	16.6	4.3	16.9	15.9	4.6	16.2	15.2	5.0
	20	19.9	16.4	3.6	19.3	16.2	3.8	18.7	15.9	4.1	18.0	15.6	4.3	17.4	15.2	4.7	16.7	14.8	5.0
	22	20.9	14.1	3.6	20.3	13.9	3.8	19.7	13.6	4.0	19.0	13.2	4.3	18.3	12.9	4.7	17.5	12.4	5.0
31	21	20.6	19.6	3.6	20.0	19.0	3.8	19.3	18.4	4.0	18.7	17.7	4.3	18.0	17.0	4.7	17.2	16.2	5.0
	22	21.0	18.8	3.6	20.4	18.6	3.8	19.8	18.4	4.0	19.1	18.0	4.3	18.3	17.4	4.7	17.6	16.6	5.0
	23	21.5	17.9	3.6	20.8	17.6	3.8	20.2	17.4	4.0	19.5	17.0	4.3	18.7	16.6	4.6	18.0	16.2	5.0
	25	22.5	15.7	3.5	21.8	15.4	3.7	21.1	15.1	4.0	20.4	14.8	4.3	19.6	14.4	4.6	18.8	13.9	5.0

# ECO ULTRA Performance Data at part load

## HEATING CAPACITY (KW)

G = Gross Heating Capacity kW, based on nominal air flow.  
 N = Net Heating Capacity kW allowing for average defrost.

PI = Power Input (kW)  
 ○ = Nominal Capacity (kW).

### OPA 336 ECO ULTRA @100% (1700 l/s)

Air on

Outdoor coil entering air temperature °C D.B.

D.B. °C	-5			-3			-1			0			3			5			7			9		
	G	N	PI	G	N	PI	G	N	PI	G	N	PI	G	N	PI	G	N	PI	G	N	PI	G	N	PI
15	21.8	20.5	8.2	23.0	20.3	8.3	24.2	20.6	8.5	24.9	21.0	8.5	26.7	24.4	8.5	28.0	28.0	8.6	29.2	29.2	8.7	30.5	30.5	8.8
20	21.4	20.3	8.8	22.7	20.0	8.9	23.9	20.3	9.1	24.5	20.7	9.1	26.4	24.2	9.1	27.7	27.7	9.2	28.9	28.9	9.3	30.1	30.1	9.5
25	20.8	19.7	9.5	22.0	19.5	9.7	23.2	19.8	9.9	23.9	20.2	9.9	25.7	23.6	9.9	27.0	27.0	10.0	28.2	28.2	10.1	29.4	29.4	10.3

### OPA 336 ECO ULTRA @Nominal (1700 l/s)

Air on

Outdoor coil entering air temperature °C D.B.

D.B. °C	-5			-3			-1			0			3			5			7			9		
	G	N	PI	G	N	PI	G	N	PI	G	N	PI	G	N	PI	G	N	PI	G	N	PI	G	N	PI
15	20.6	19.5	7.4	21.8	19.2	7.4	23.0	19.5	7.6	23.6	19.9	7.6	25.4	23.2	7.6	26.5	26.5	7.7	27.7	27.7	7.8	28.9	28.9	7.8
20	20.3	19.2	7.9	21.5	19.0	8.0	22.7	19.3	8.2	23.3	19.6	8.2	25.1	22.9	8.2	26.2	26.2	8.2	27.4	27.4	8.3	28.6	28.6	8.4
25	19.7	18.7	8.5	20.9	18.5	8.6	22.0	18.7	8.8	22.6	19.1	8.8	24.4	22.4	8.8	25.6	25.6	8.9	26.8	26.8	9.0	27.9	27.9	9.1

### OPA 336 ECO ULTRA @Nominal -10% (1700 l/s)

Air on

Outdoor coil entering air temperature °C D.B.

D.B. °C	-5			-3			-1			0			3			5			7			9		
	G	N	PI	G	N	PI	G	N	PI	G	N	PI	G	N	PI	G	N	PI	G	N	PI	G	N	PI
15	18.6	17.5	6.3	19.6	17.3	6.4	20.7	17.5	6.5	21.2	17.9	6.5	22.8	20.8	6.5	23.8	23.8	6.5	24.9	24.9	6.6	26.0	26.0	6.7
20	18.3	17.3	6.8	19.3	17.1	6.8	20.4	17.3	7.0	20.9	17.7	7.0	22.5	20.6	7.0	23.6	23.6	7.0	24.6	24.6	7.1	25.7	25.7	7.2
25	17.7	16.8	7.3	18.8	16.6	7.4	19.8	16.9	7.5	20.3	17.2	7.5	21.9	20.1	7.5	23.0	23.0	7.6	24.1	24.1	7.7	25.1	25.1	7.8

### OPA 336 ECO ULTRA @Nominal -20% (1700 l/s)

Air on

Outdoor coil entering air temperature °C D.B.

D.B. °C	-5			-3			-1			0			3			5			7			9		
	G	N	PI	G	N	PI	G	N	PI	G	N	PI	G	N	PI	G	N	PI	G	N	PI	G	N	PI
15	16.5	15.5	5.4	17.4	15.4	5.4	18.4	15.6	5.5	18.8	15.9	5.5	20.3	20.3	5.5	21.2	21.2	5.6	22.1	22.1	5.6	23.1	23.1	5.7
20	16.3	15.4	5.8	17.2	15.2	5.8	18.1	15.4	5.9	18.6	15.7	5.9	20.0	20.0	5.9	21.0	21.0	6.0	21.9	21.9	6.0	22.8	22.8	6.1
25	15.7	14.9	6.2	16.7	14.8	6.3	17.6	15.0	6.4	18.1	15.3	6.4	19.5	19.5	6.4	20.4	20.4	6.4	21.4	21.4	6.5	22.3	22.3	6.6

### OPA 336 ECO ULTRA @Nominal -30% (1700 l/s)

Air on

Outdoor coil entering air temperature °C D.B.

D.B. °C	-5			-3			-1			0			3			5			7			9		
	G	N	PI	G	N	PI	G	N	PI	G	N	PI	G	N	PI	G	N	PI	G	N	PI	G	N	PI
15	14.4	13.6	4.7	15.3	13.4	4.7	16.1	13.6	4.8	16.5	13.9	4.8	17.7	17.7	4.8	18.5	18.5	4.8	19.4	19.4	4.9	20.2	20.2	4.9
20	14.2	13.4	5.0	15.0	13.3	5.0	15.9	13.5	5.1	16.3	13.7	5.1	17.5	17.5	5.1	18.3	18.3	5.1	19.2	19.2	5.2	20.0	20.0	5.2
25	13.8	13.1	5.3	14.6	12.9	5.4	15.4	13.1	5.4	15.8	13.4	5.5	17.1	17.1	5.4	17.9	17.9	5.5	18.7	18.7	5.5	19.5	19.5	5.6

### OPA 336 ECO ULTRA @Nominal -50% (1700 l/s)

Air on

Outdoor coil entering air temperature °C D.B.

D.B. °C	-5			-3			-1			0			3			5			7			9		
	G	N	PI	G	N	PI	G	N	PI	G	N	PI	G	N	PI	G	N	PI	G	N	PI	G	N	PI
15	10.5	9.9	3.5	11.1	9.8	3.5	11.7	9.9	3.6	12.0	10.1	3.6	12.9	12.9	3.6	13.5	13.5	3.6	14.1	14.1	3.6	14.7	14.7	3.6
20	10.4	9.8	3.7	11.0	9.7	3.7	11.6	9.8	3.7	11.9	10.0	3.7	12.8	12.8	3.7	13.4	13.4	3.8	14.0	14.0	3.8	14.6	14.6	3.8
25	10.0	9.5	3.9	10.6	9.4	3.9	11.2	9.6	4.0	11.5	9.8	4.0	12.4	12.4	4.0	13.0	13.0	4.0	13.6	13.6	4.0	14.2	14.2	4.0

# Air Cooled Packaged Units

## Performance Data



### AIR HANDLING

**Note:** Airflows are for a dry coil. Reduce airflow by 5% in high moisture removal conditions. In a free blow or low resistance application, beware of exceeding indoor fan motor's full load amp limit (refer back page). Air flows given are for units installed without filters.

#### OPA 336

#### Optional Filters - Pressure Drop

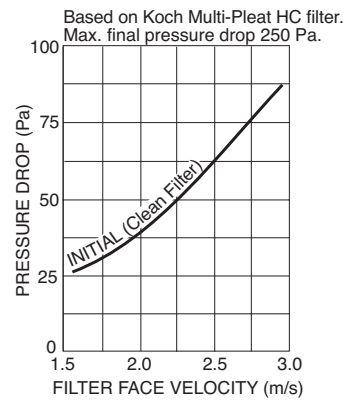
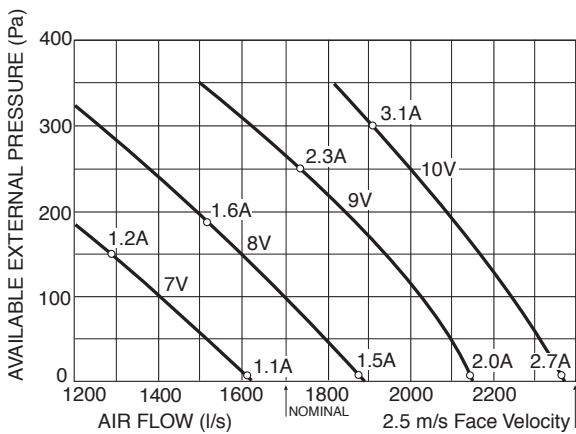

### INDOOR AIR FLOW CORRECTION FACTORS @ NOMINAL CONDITIONS

	Indoor Air Flow (%)			
	-20%	-10%	Rated	+10%
Total Capacity	0.95	0.975	1.0	1.025
Sensible Capacity	0.89	0.950	1.0	1.050

# Air Cooled Packaged Units

## Performance Data



### SOUND LEVELS

#### Sound Power Levels (SWL) - Radiated

Measured in decibels re 1 picowatt, at nominal airflow.

Model	OUTDOOR FAN SPEED	SWL dB(A)	OCTAVE BAND FREQUENCY Hz					
			125	250	500	1K	2K	4K
OPA 336	HIGH	81	82	79	79	76	71	64

#### Sound Pressure Levels (SPL)

Measured in decibels re 20  $\mu$ Pa, at nominal airflow.

Model	OUTDOOR FAN SPEED	SPL dB(A) @ 3m	OCTAVE BAND FREQUENCY Hz					
			125	250	500	1K	2K	4K
OPA 336	HIGH	65	66	63	63	60	55	48

#### Sound Power Levels (SWL) - Supply Air Outlet

**Test Conditions:** BS 848.2 : 2004.

Direct method of measurement (reverberant room).

Installation Type A (free inlet and outlet).

Measured in decibels re 1 picowatt.

Model	INDOOR FAN SPEED	SWL dB(A)	OCTAVE BAND FREQUENCY Hz					
			125	250	500	1K	2K	4K
OPA 336	9V	81	73	86	79	73	72	67
	6V	68	73	66	67	61	59	53

# Air Cooled Packaged Units

## Dimensions (mm)



FIG. 1 OPA 336RKTFO1-P : HORIZONTAL SUPPLY & RETURN AIR

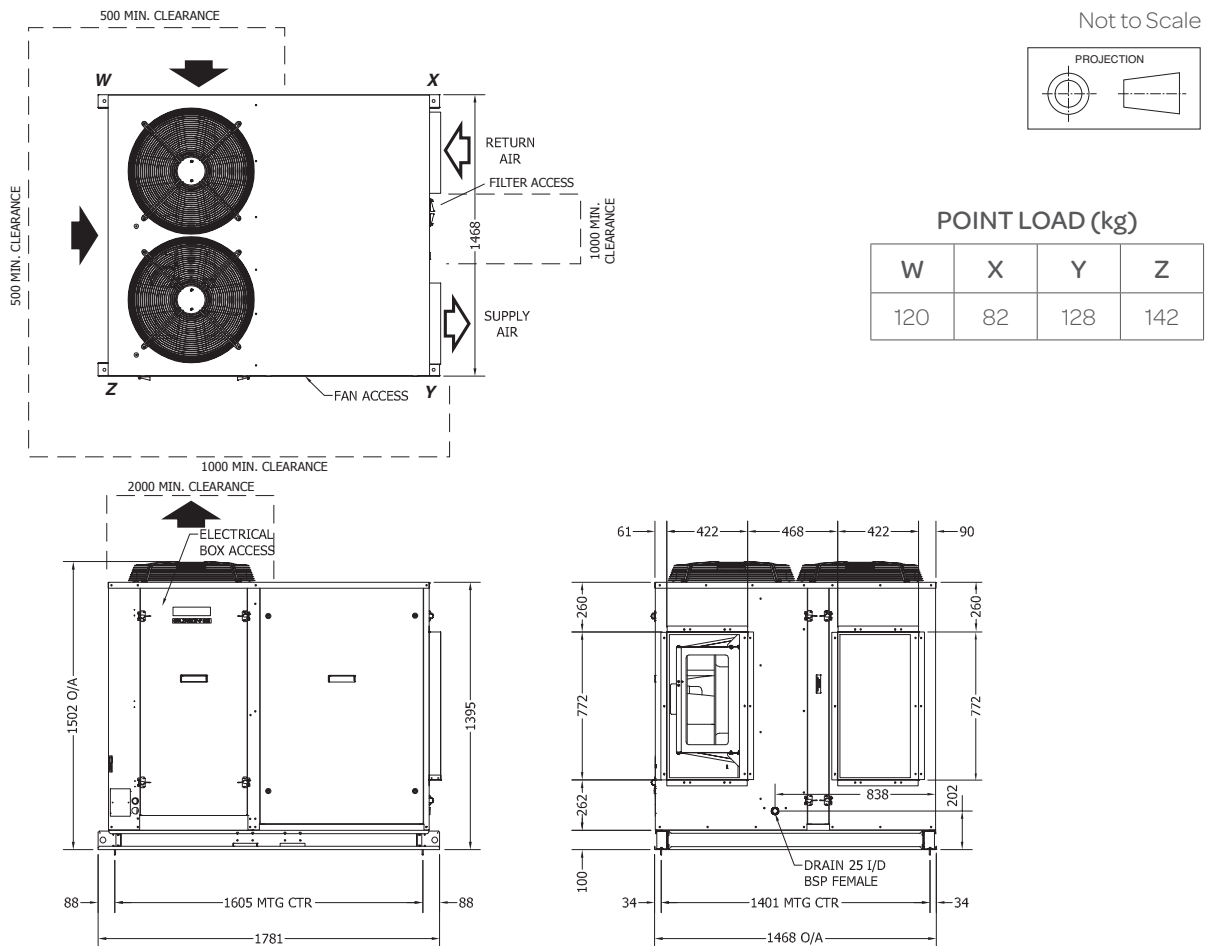
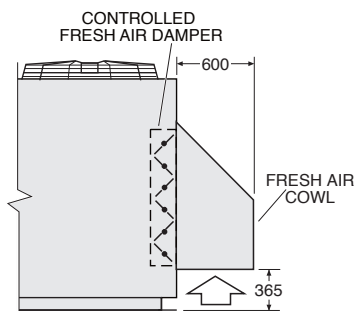
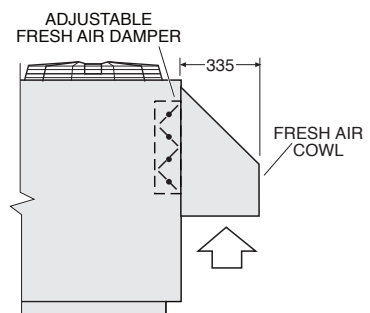

FIG. 3 ECONOMISER & FRESH AIR DAMPER OPTIONS

Economiser Fresh Air Cowl



Fresh Air Cowl



**Note:** The manufacturer reserves the right to make changes in specifications at any time without notice or obligation. Certified data is available on request.

# Air Cooled Packaged Units

## Dimensions (mm)



**FIG. 2 OPA 336RKTf23-P : DOWNWARD SUPPLY & RETURN AIR**

Not to Scale

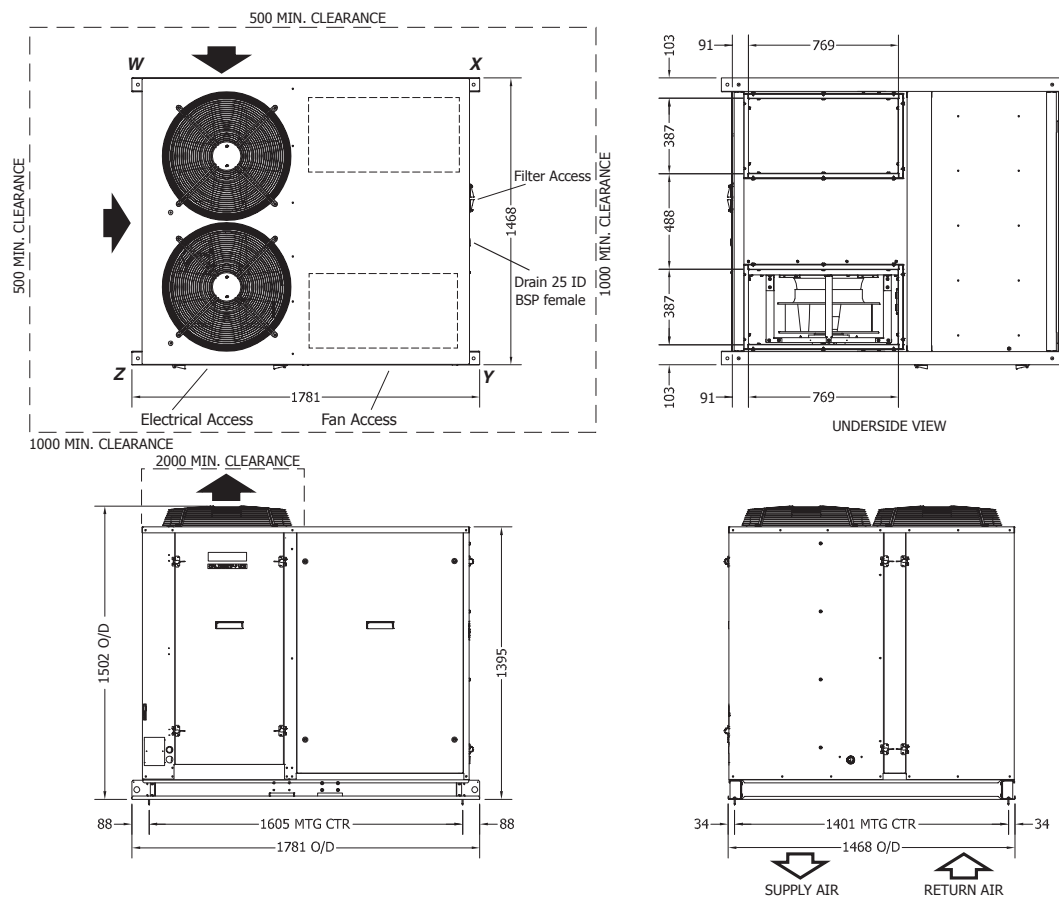
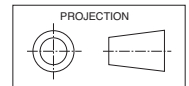

**POINT LOAD (kg)**

W	X	Y	Z
75	60	153	191

**Note:** The manufacturer reserves the right to make changes in specifications at any time without notice or obligation. Certified data is available on request.

# Air Cooled Packaged Units

## Specifications



Eco Ultra Model	OPA 336RKTf-P
<b>System</b>	
Nominal Cooling Capacity * <sup>1</sup> kW	29.3 (17.6 ~ 33.6)
Net Cooling Capacity (MEPS) * <sup>1</sup> kW	28.3
EER / AEER (cooling)	3.34 / 3.32
Heating Capacity * <sup>2</sup> kW	27.4 (14.0 ~ 28.9)
COP / ACOP (heating)	3.28 / 3.27
Unit Controller	UC8
Refrigerant	R410A
Nominal Air Flow at rating conditions l/s	1700
Power Source	3 phase 400 V a.c. 50 Hz
Compressor Type	DC Inverter
Indoor air fan type	backward curved, plug
Indoor air fan motor	EC plug 2.5 kW
Indoor Fan (3ph.) max. current A/ph.	3.3
Running amps	13.5 / 15.5 / 13.0
Max. Running amps	19.5 / 21.0 / 18.5
Finish	grey polyester powder coat
<b>Weight kg</b>	
Net Weight	472
Shipping Weight (approx.)	510

### Notes:

- \*<sup>1</sup> Nominal Cooling Capacity at AS/NZS 3823 conditions:  
 - Indoor Entering Air Temp. 27°C D.B., 19°C W.B.;  
 - Outdoor Entering Air Temp. 35°C D.B.  
 Subtract indoor fan power to calculate Net Capacity.  
 Range is adjustable – refer to temperzone.
- \*<sup>2</sup> Heating Capacity at AS/NZS 3823 conditions:  
 - Indoor Entering Air Temp. 21°C D.B.;  
 - Outdoor Entering Air Temp. 7°C D.B., 6°C W.B.  
 Range is adjustable – refer to temperzone.
- \*<sup>3</sup> Supply air flow at Nominal Cooling Capacity conditions stated above.



---

www.temperzone.biz

---

**AUCKLAND**

**Head Office**

38 Tidal Rd, Mangere, N.Z.  
Private Bag 93303, Otahuhu,  
NEW ZEALAND.

Email [sales@temperzone.co.nz](mailto:sales@temperzone.co.nz)

Phone (09) 279 5250

Fax (09) 275 5637

**SYDNEY**

**Head Office**

14 Carnegie Place, Blacktown,  
NSW 2148  
PO Box 8064, Seven Hills West,  
NSW 2147, AUSTRALIA.

Email [sales@temperzone.com.au](mailto:sales@temperzone.com.au)

Phone (02) 8822 - 5700

Fax (02) 8822 - 5711

**NEWCASTLE**

Phone (02) 4962 - 1155

Fax (02) 4961 - 5101

**LAUNCESTON**

Phone (03) 6331 - 4209

Fax (03) 6333 - 0224

**WELLINGTON**

Phone (04) 569 3262

Fax (04) 566 6249

**ADELAIDE**

Phone (08) 8115 - 2111

Fax (08) 8115 - 2118

**JAKARTA**

Phone +62 (21) 2963 4983

Fax +62 (21) 2963 4984

**CHRISTCHURCH**

Phone (03) 379 3216

Fax (03) 379 5956

**MELBOURNE**

Phone (03) 8769 - 7600

Fax (03) 8769 - 7601

**SINGAPORE**

Phone +65 6733 4292

Fax +65 6235 7180

**BRISBANE**

Phone (07) 3308 - 8333 or  
1800 - 897 - 253

Fax (07) 3308 - 8330

**SHANGHAI**

Phone +86 (21) 5648 2078

**PERTH**

Phone (08) 6399 - 5900

Fax (08) 6399 - 5932



Available from