

IMD 420Y, 550Y (c/w EC motor)

Ducted Fan Coil Units

Installation & Maintenance

Dimensions (mm)

Not to Scale

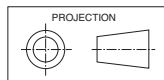

MODEL	CORNER LOADS (kg)			
	W	X	Y	Z
IMD 420Y	35	42	38	30
IMD 550Y	42	47	37	40

Net Weight
(excluding water)
IMD 420Y 145 kg
IMD 550Y 166 kg

Fig. 1

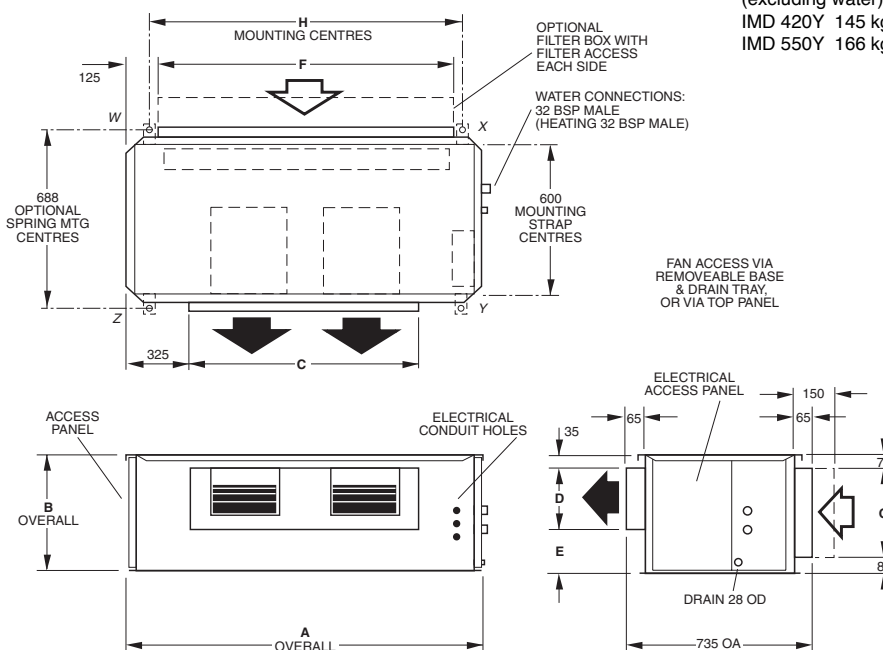

MODEL	A	B	C	D	E	F	G	H
IMD 420	1625	575	975	300	240	1375	425	1518
IMD 550	1680	700	1030	310	355	1430	555	1573

Note: The manufacturer reserves the right to change specifications at any time without notice or obligation. Certified dimensions available on request.

GENERAL

The IMD ducted fan coil units must be installed in accordance with all national and local safety codes.

Options

1. Filter Box
2. Spring Mounting Kit

FILTER BOX (Option)

The Filter Box is installed by unscrewing the return air spigot and replacing it with the Filter Box's filter-integrated spigot. The filter may be accessed from either side of this spigot. This new spigot has a depth of 150 mm, instead of 65 mm.

INSTALLATION

Positioning & Mounting

Provide 500 mm minimum clearance to both ends of the unit. If the filter box option is to be used, allow adequate clearance for the filter to be withdrawn to its full length.

If low noise is a critical factor in the installation, refer to Figure 5 for noise isolation recommendations.

It is recommended that the unit be mounted using the spring mounting system, supplied as an optional extra (Fig.2). This system minimises transfer of vibration into the building structure.

If a more rigid installation can be tolerated, then suspend the unit using the four straps supplied, as shown in Figure 3.

Alternatively, holes are supplied in the mounting flange for the use of threaded mounting rods (not supplied).

The unit has a built-in sloping drain tray, therefore mount it level.

Condensate Drain

The condensate drain should be trapped outside the unit cabinet. The trap should have a vertical height of at least 50 mm. The drain should have a slope of at least 1 in 50 and must not be piped to a level above the unit drain tray. (Refer Fig.4). Use flexible tube to connect the unit's drain stub to the external drain pipe.

For long condensate pipe runs, fit a vent pipe near the drain trap. The top of the vent pipe must be at least 100 mm above the IMD unit's drain tray.

It is essential that the drainage system is checked by pouring water in the drain tray and seeing that it discharges at the end of the drain and does not overflow the drain tray.

Note: The built-in drain tray can be removed for cleaning (or fan access) by first removing the unit's base.

Fig. 2 Spring Mounting

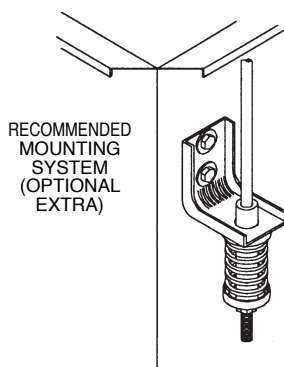
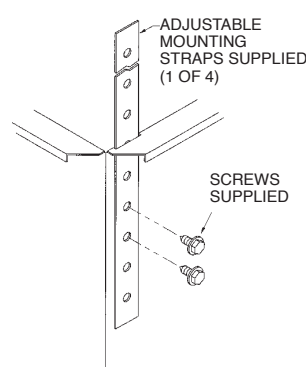

Fig. 3 Strap Mounting



ELECTRICAL WIRING

The electrical supply required (including voltage fluctuation limits) is:
1 phase 200-252 V a.c. 50 Hz with neutral and earth. The supply to have an isolation switch adjacent to the unit but not attached to the unit. Recommended external fuse size is 16 amp H.R.C.

Electrical work must be carried out by a qualified electrician in accordance with local supply authority regulations and the wiring diagram.

FAN CONTROL

Overview

The fan can be controlled between selectable low and high levels using either:
1. 0–10V DC control voltage (ie continuously variable), **or**
2. (up to) 3 contact inputs (ie stepped).

Only one control method must be connected at any one time; **not both**.

Fan run on is provided with durations suiting water sourced and electric heating systems.

Control Levels (Output Voltages)

DIP switches 1-4 of the Analog Level Controller (ALC on wiring schematic) select the low fan control voltage level. DIP switches 5 and 6 select the high fan control voltage level as a set amount above the low level.

The medium level setting is half way between the low and high setting levels.

The control voltage settings apply to both 0-10V and contact input control levels.

Refer to the wiring schematic diagram for the default settings and the available level settings.

Contact Inputs

Voltage free contact inputs can be used to operate the fan at the selected control levels.

0-10V Input

A 0–10V DC signal can be used to control the fan. The fan is stopped for input signals below 1.6V. The fan operates at the selected low level when the input signal is between 1.6 and 2.0V. As the input signal increases above 2V the fan control signal increases linearly reaching the selected high level when the input signal is 10V.

Run-On

The run-on duration is selected with DIP switch 8 for either 40 seconds or 120 seconds for electric heating systems. If electric heating is fitted ensure DIP switch 8 is set on for 120 seconds run on.

The fan will run-on for the selected period when the 0-10V input falls below 1.6V and all the contact inputs are opened. If the 0-10V input signal remains below 1.6V and the contact inputs remain open the fan will stop at the end of the run-on period.

Note

Select fan control levels that avoid water carry-over problems.

COMMISSIONING

1. Check that the thermostat is correctly wired and set at the desired temperature.
2. Check that the air filter (if fitted) is clean.
3. Check that the fan runs freely without vibration.
4. Check condensate drain for free drainage.

Fig. 4

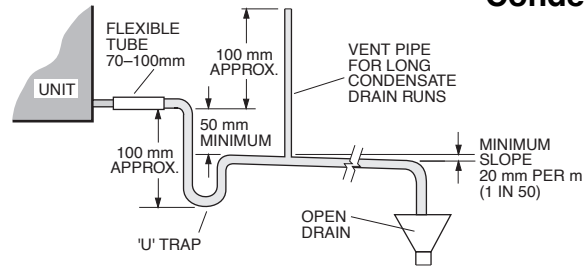

Condensate Drain

MAINTENANCE

Weekly For First Four Weeks

1. Check air filter (if fitted); vacuum clean as necessary.
2. Check condensate drain for free drainage.

Monthly

Check air filter (if fitted); vacuum clean as necessary.

Six Monthly

1. Check condensate drain for free drainage.
2. Check heat exchanger coil; vacuum or brush clean as necessary.
3. Check the tightness of the fan.
4. Check that fan motor is free running.
5. Check tightness of electrical connections.
6. Check air supply at diffuser outlets.

NOTE

The manufacturer reserves the right to change specifications at any time without notice or obligation. Certified dimensions available on request.

This pamphlet replaces the previous issue no. 3831 dated 11/19.
Fig.4 flexible drain conn..

Fig. 5 Application Considerations

Recommendations for Noise Isolation - particularly for high static installations:

1. Avoid installing units, with non-ducted return air, directly above spaces where noise is critical.
2. Use flexible connections between unit and rigid ducting.
3. Use generously sized acoustically lined ducts.
4. If generous duct size is not possible, use turning vanes on bends to reduce air turbulence (regenerated noise).
5. Use 90° bends in ducting to significantly assist in noise reduction.

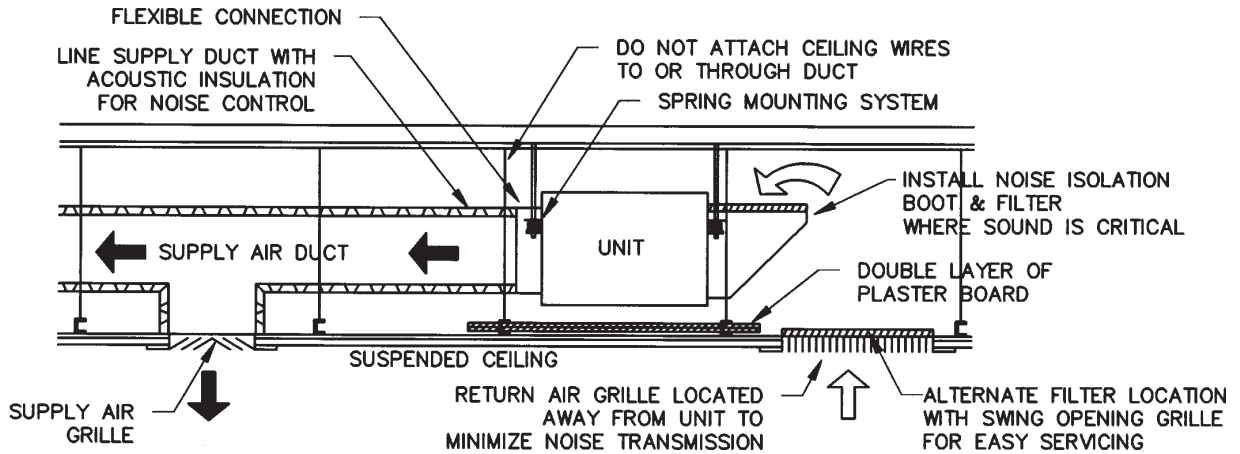
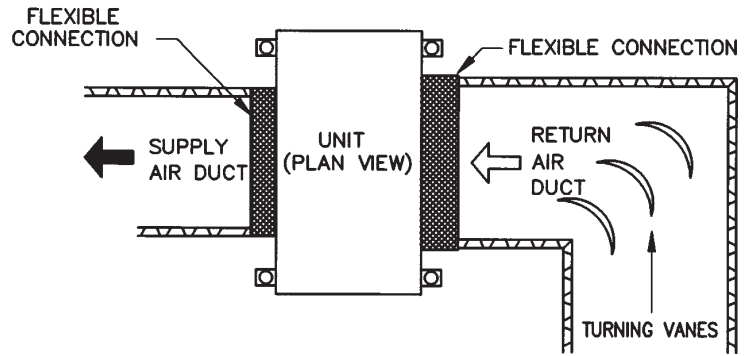

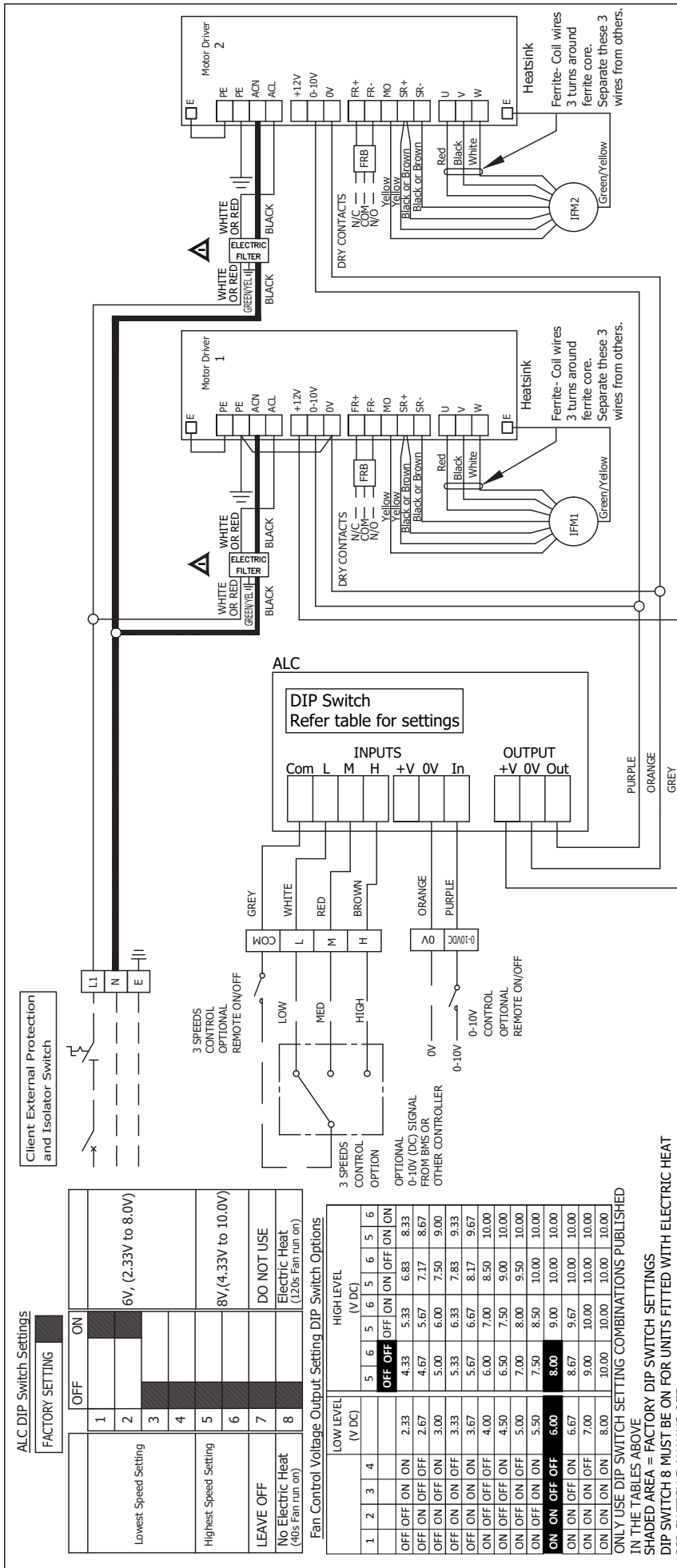

ALC DIP Switch Settings

FACTORY SETTING	OFF	ON
1		
2		
3		6V, (2.33V to 8.0V)
4		
5		8V, (4.33V to 10.0V)
6		
7		DO NOT USE
8		Electric Heat (40s Fan run on)

Fan Control Voltage Output Setting DIP Switch Options

DIP Switch	HIGH LEVEL (V DC)					
	5	6	5	6	5	6
OFF	4.33	5.33	6.33	6.83	8.33	8.33
ON	2.33	2.67	3.00	3.33	3.67	4.00
OFF	4.67	5.67	6.67	7.17	8.67	8.67
ON	2.67	3.00	3.33	3.67	4.00	4.33
OFF	5.00	6.00	7.00	7.50	9.00	9.00
ON	3.33	3.67	4.00	4.33	4.67	5.00
OFF	6.33	6.67	7.00	7.33	7.67	8.00
ON	3.67	4.00	4.33	4.67	5.00	5.33
OFF	7.00	8.00	9.00	9.50	10.00	10.00
ON	4.50	5.00	5.50	6.00	6.50	7.00
OFF	7.50	8.50	10.00	10.00	10.00	10.00
ON	5.50	6.00	6.50	7.00	7.50	8.00
OFF	8.00	9.00	10.00	10.00	10.00	10.00
ON	6.67	7.00	7.33	7.67	8.00	8.33
OFF	8.33	9.00	10.00	10.00	10.00	10.00
ON	7.00	7.33	7.67	8.00	8.33	8.67
OFF	10.00	10.00	10.00	10.00	10.00	10.00
ON	8.00	8.33	8.67	9.00	9.33	9.67

ONLY USE DIP SWITCH SETTING COMBINATIONS PUBLISHED IN THE TABLES ABOVE
 SHADED AREA = FACTORY DIP SWITCH SETTINGS
 DIP SWITCH 8 MUST BE ON FOR UNITS FITTED WITH ELECTRIC HEAT
 DIP SWITCH 7 ALWAYS OFF
 Lowest Speed Setting DIP Switch 1 to DIP Switch 4 (LOW)
 Highest Speed Setting DIP Switch 5 & DIP Switch 6 (HIGH)

NOTE: Do NOT connect BOTH 3 speed L/M/H switch and also 0-10V (DC) signal.
 Only ONE control method may be connected at a time.
 If in doubt ask!

With the 3 speed control the Medium (MED) level is always halfway between HIGH and LOW levels.

ISSUE	MODIFICATION	ECN	DATE	APRVD
I	Added option of "OR RED" on electrical filter for white wire and removed "OR RED" option from black wire	I4283	18-11-19	A.S.
H	ALC Version Upgraded to 201-000-092; New DIP Switch Settings	I4059	13-07-18	P.M.C
G	SPEED SETTING 4.55V CORRECTED TO 8V SPEED RANGE 2.55V CORRECTED TO 6V	I4059	15-05-18	A.K.B
F	ECC 1.60 REMOVED MOTOR DRIVER, OR RED ADDED TO FILTER WIRE COLOURS, ALC DIP SWITCH SETTINGS UPDATED	I4013	10-01-18	A.K.B
E	CHANGED EARTHING ARRANGEMENT, REMOVED TERM. FOR REMOTE ON/OFF	---	20-8-15	W.A.S
D	CHANGED WIRING COLOURS TO MATCH STANDARD PRODUCTS	---	20-8-15	W.A.S

ALC	ANALOGUE LEVEL CONTROLLER
IFM	INDOOR FAN MOTOR
FRB	FAULT RELAY BOARD
CLIENT WIRING	---
MODEL	IMD 420Y, 550Y
VOLTAGE IN	V 230/240
ECC MOTOR DRIVER AMPS (MAX)	7.4A/MTR

Title **MD420Y, 550Y**
WIRING SCHEMATIC

Drawn K.L.E
 Date 12-02-15
 Aprvd *PCL*

Revision No. **291-000-103**
 Revision **I**