

Distributed by



Gassero

technology for your comfort



ECO-FRIENDLY

WALL HUNG CONDENSING BOILERS

www.gassero.com

Wall Hung Boilers

Wallcon X-treme



Capacity (kW)							
42	50	67	70	90	115	125	150
●	●	●			●	●	●

Alucon



Capacity (kW)							
42	50	67	70	90	115	125	150
	●		●	●	●	●	●

Wall Hung Boilers

Wallcon X-treme

- 42-150 kW capacity range,
- Stainless Steel Heat Exchanger
- Low NOx values
- Low flue gas temperatures
- Turndown ratio up to 15:100
- Efficiency up to %107,2 according to EN 15502-1+A1
- Suitable with B23, C13, C33, C43, C53, C63, C83 flue types

Alucon

- 50-150 kW capacity range,
- Aluminum heat exchanger
- Low NOx values
- Low flue gas temperatures
- Turndown ratio up to 14:100
- Efficiency up to %108,2 according to EN 15502-1+A1
- Suitable B23, C13, C33, C43, C53, C63, C83 flue types

Premix and Condensation Technology Explained

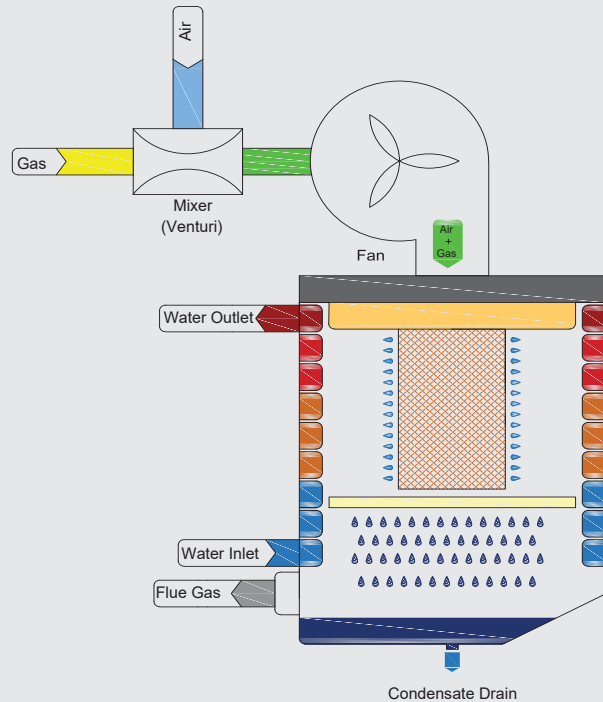

Condensation technology is an effective method for converting natural gas into beneficial energy by combustion. Hidden energy of hot flue gas in water vapor gain into the system and provides energy efficiency.

Condensing boilers are operate with low flue gas temperatures. Miixing of the air and gas used in the energy production to obtain an efficient combustion before get inside the combustion chamber is named as premix.

Premix systems provide lower emissions values (NOx-CO) after combustion.

Wallcon X-treme

Wall Hung Condensing Boiler



- 42-150 kW capacity range
- Stainless steel heat exchanger
- Low NOx values
- Low flue gas temperatures
- Integrated non-return flue valve
- Turndown ratio up to 15:100
- Integrated cascade management up to 16 boilers
- Low noise level
- Efficiency up to %107,2 according to EN 15502-1+A1
- Fires both NG and LPG
- Integrated circulating pump
- Energy class A

Product Specifications



- Efficient and durable heat exchanger
- ErP circulating pump
- Latest technology, low emission premix burner
- High modulating and energy-efficient fan

Safety Features:

- Frost protection
- Overheat protection
- Low and high water pressure safety
- Flue gas temperature and pressure safety
- Pump/valve protection
- Legionella protection for DHW tank
- Condensate blockage safety with siphon sensor
- Fan speed safety

Wallcon X-treme

Technical Specifications

		Wallcon X-treme					
		42	50	67	115	125	150
THERMAL SPECIFICATIONS							
	Unit						
Nominal heat input (min/max)	kW	7,2/39,4	8,4/48,0	11,2/63,0	27,0/108,5	17,0/121,0	21,0/143,0
Nominal heat output (80/60°C) (min/max)	kW	7,0/38,3	8,1/46,3	11,0/61,0	26,1/105,4	16,6/116,2	19,5/138,0
Nominal heat output (50/30°C) (min/max)	kW	7,6/41,3	8,9/50,1	12,0/67,0	29,3/115,5	18,4/126,0	22,7/150,0
Heating efficiency (80/60°C) (min/max)	%	97,0/97,8	96,9/97,6	98,0/98,8	97,3/97,3	95,3/97,1	96,5/97,0
Heating efficiency (50/30°C) (min/max)	%	105,6/104,9	105,8/104,4	107,1/106,4	107,2/106,5	106,1/106,2	106,5/105,3
Partial load efficiency (36/30°C)	%	108,2	108,3	108,1	108,0	108,0	108,3
Turndown ratio		19:100	18:100	18:100	25:100	15:100	15:100
HYDRAULIC SPECIFICATIONS							
Operation water pressure (min/max)	bar	0,8/3,0	0,8/3,0	0,8/4,5	0,8/6,0	0,8/6,0	0,8/6,0
Exchanger water volume	lt	5,05	5,05	5,97	8,2	8,2	9,7
Water flow rate (min/max)	m³/h	0,3/1,7	0,4/2,1	0,5/2,9	1,2/5,1	0,8/5,2	0,9/6,0
Pump head	mWC	6,0	5,5	3,5	7,7	7,2	10,6
Max. operation temp.	°C	80	80	80	80	80	80
Limit shut off temp.	°C	105	105	105	105	105	105
GAS AND COMBUSTION SPECIFICATIONS							
Gas Type		G20/G30	G20/G30	G20/G30	G20/G30	G20/G30	G20/G30
Gas supply pressure (G20/G31)	mbar	20/30	20/30	20/30	20/30	20/30	20/30
Flue gas pressure	Pa	100	140	170	200	190	310
Combustion products flow rate (min/max)	g/sn	3,0/17,0	4,0/21,0	5,0/28,0	12,0/47,0	8,0/49,0	9,0/60,0
CO2 emission (min/max)	%	8,9/9,1	9/9,3	8,6/9,1	9,1/9,1	9,1/9,1	9,4/9,8
Flue gas temp. (80/60°C) (min/max)	°C	63,5/65,3	64,8/66,6	56,9/69,9	58,9/78,3	57,6/80,1	62,9/83,0
Flue gas temp. (50/30°C) (min/max)	°C	40,4/42,1	43,4/46,5	35,1/47,7	33,6/40,6	32,1/42,2	38,1/65,8
NOx class		6	6	6	6	6	6
NOx value	mg/kWh	42	25	24	24	35	41
Gas consumption (min/max)	m³/h	1,0/3,9	0,9/4,8	1,3/6,1	2,7/10,7	1,7/11,4	2,1/14,2
INSTALLATION SPECIFICATIONS							
Boiler water inlet (F) / outlet diameter (E)	DN	25/25	25/25	25/25	32/32	32/32	32/32
Fresh air (A) / flue gas diameter (G) (B23)	mm	80/80	80/80	80/80	110/100	110/100	110/100
Fresh air / waste gas diameter (Hermetic)	mm	125/80	125/80	125/80	150/100	150/100	150/100
Gas supply diameter (S)	DN	20	20	20	25	25	25
ELECTRICAL SPECIFICATIONS							
Power supply	V/Hz	230/50	230/50	230/50	230/50	230/50	230/50
Electrical consumption	W	120	130	190	350	360	460
GENERAL SPECIFICATIONS							
Energy efficiency class		A	A	A	A	A	A
Noise power level	dB(A)	53,5	55,5	63,0	58,5	60,4	61,7
Dimensions (WxDxH)	mm	485x490x610	485x490x610	485x490x610	557x580x865	557x580x865	557x580x865
Boiler weight	kg	41	41	55	86	86	95

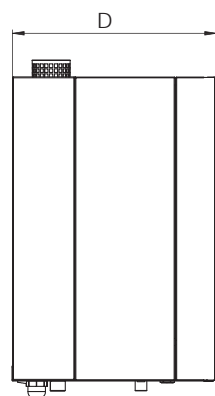
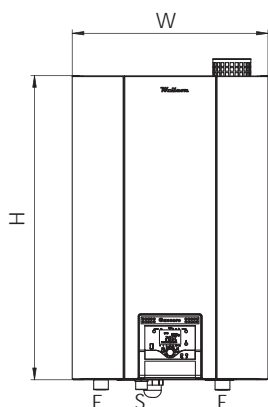

Wallcon X-treme 42 - 50 - 67

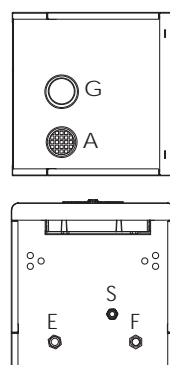

Wallcon X-treme 115 - 125 - 150

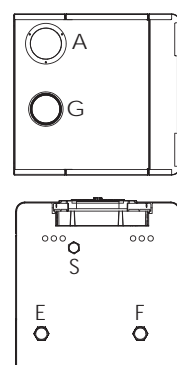



Alucon

Wall Hung Condensing Boiler



- › 50-150 kW capacity range
- › Aluminum heat exchanger
- › Low NOx values
- › Low flue gas temperature
- › Integrated back draught shutter Turndown ratio up to 14:100
- › Cascade operation option up to 16 boilers
- › Low noise level
- › Efficiency up to %108,2 according to EN 15502-1+A1
- › With external circulation pump
- › Energy class A
- › 6 Bar operation pressure



Product Specifications



- › High corrosion and lime resistance
- › Circulation pump suitable with ErP regulation
- › Low emission premix burner
- › High modulating and energy-efficient fan

Safety Features:

- Frost protection
- Overheat protection
- Low and high water pressure safety
- Flue gas temperature and pressure safety
- Pump/valve protection
- Legionella protection for DHW tank
- Condensate blockage safety with siphon sensor
- Fan speed safety

Technical Specifications

		Alucon					
		50	70	90	115	125	150
THERMAL SPECIFICATIONS		Unit					
Nominal heat input (min/max)	kW	7,6/49,2	10,2/65,6	14,9/88,3	14,9/112,3	19,9/123,5	19,9/143,1
Nominal heat output (80/60°C) (min/max)	kW	7,3/47,8	9,9/63,4	14,3/86,3	14,3/109,5	19,2/120,8	19,2/139,8
Nominal heat output (50/30°C) (min/max)	kW	8,4/51,4	11,6/68,5	15,1/91,0	15,1/118,1	22,3/128,0	22,3/149,1
Heating efficiency (80/60°C) (min/max)	%	96,9/97,7	96,7/97,2	96,8/98,4	96,8/98,2	97,0/98,3	97,0/98,2
Heating efficiency (50/30°C) (min/max)	%	108,1/105,9	108,0/103,9	108,2/105,0	108,2/104,8	108,1/104,4	108,1/103,2
Partial load efficiency (36/30°C)	%	108,6	108,4	108,5	108,7	108,5	108,4
Turndown ratio		16:100	16:100	17:100	14:100	17:100	14:100
HYDRAULIC SPECIFICATIONS							
Operation water pressure (min/max)	bar	0,8/6,0	0,8/6,0	0,8/6,0	0,8/6,0	0,8/6,0	0,8/6,0
Exchanger water volume	lt	3,2	3,2	4,6	4,6	6,0	6,0
Water flow rate (min/max)	m³/h	0,4/2,2	0,5/3,0	0,7/3,8	0,7/4,8	1,0/5,4	1,0/6,2
Pump head	mWC	3	3	5	5	5,5	5,5
Max. operation temp.	°C	85	85	85	85	85	85
Limit shut off temp.	°C	95	95	95	95	95	95
GAS AND COMBUSTION SPECIFICATIONS							
Gas Type		G20	G20	G20	G20	G20	G20
Gas supply pressure (G20/G31)	mbar	20	20	20	20	20	20
Flue gas pressure	Pa	100	130	170	200	220	330
Combustion products flow rate (min/max)	g/sn	3,0/22,0	5,0/28,0	6,0/39,0	6,0/49,0	9,0/54,0	9,0/63,0
CO2 emission (min/max)	%	9,32/9,36	9,05/9,61	9,44/9,33	9,44/9,36	9,54/9,49	9,54/9,56
Flue gas temp. (80/60°C) (min/max)	°C	54,7/65,6	55,4/72,1	56,8/61,4	56,8/64,9	56,9/61,8	56,9/70,3
Flue gas temp. (50/30°C) (min/max)	°C	29,5/45,1	30,1/52,3	30,2/448,8	30,2/53,5	30,5/44,9	30,5/47,1
NOx class		6	6	6	6	6	6
NOx value	mg/kWh	37	28	39	43	46	44
Gas consumption (min/max)	m³/h	0,8/5,1	1,1/6,8	1,6/9,2	1,6/11,7	2,1/12,8	2,1/14,9
INSTALLATION SPECIFICATIONS							
Boiler water inlet (F) / outlet diameter (E)	DN	25/25	25/25	25/25	25/25	25/25	25/25
Fresh air (A) / flue gas diameter (G) (B23)	mm	80/100	80/100	110/100	110/100	110/100	110/100
Fresh air / waste gas diameter (Hermetic)	mm	150/100	150/100	150/100	150/100	150/100	150/100
Gas supply diameter (S)	DN	20	20	25	25	25	25
ELECTRICAL SPECIFICATIONS							
Power supply	V/Hz	230/50	230/50	230/50	230/50	230/50	230/50
Electrical consumption	W	52	97	116	203	212	313
GENERAL SPECIFICATIONS							
Energy efficiency class		A	A	A	A	A	A
Noise power level	dB(A)	57,2	66,2	58,8	61,3	66,4	69,3
Dimensions (WxDxH)	mm	510x540x770	510x540x770	510x540x770	510x540x770	600x540x770	600x540x770
Boiler weight	kg	69	69	79	79	91	91

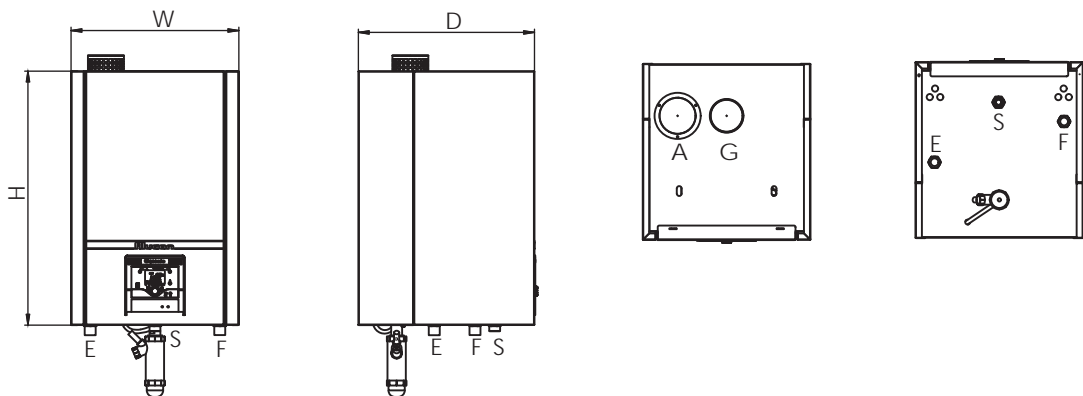

Advantages of The Condensing Boilers

- ▶ Condensation technology approximately %15 more efficient when compared with conventional systems with heat recovery
- ▶ Provides reduced fuel consumption with low flue gas temperatures and efficient combustion technology,
- ▶ Provides high modulation operation and low energy consumption with energy efficient pump,
- ▶ Provides less pollutant emissions with reduced gas consumption.

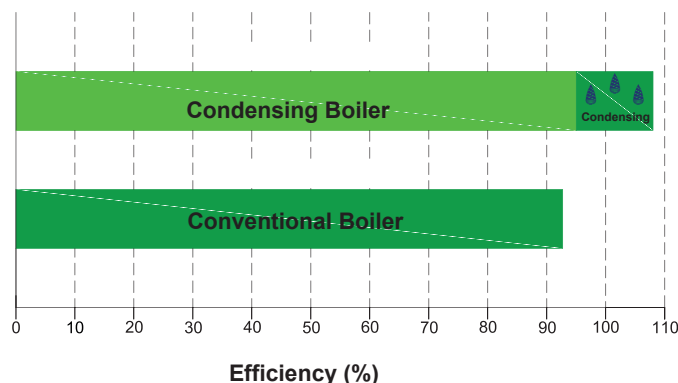

Calculation Example:

Comparison of the natural gas consumption values between conventional and condensing boiler systems for a plant which needs 2.000.000 kcal/h and operating at 80 °C supply, 60 °C return water temperature is examined in the table below.

- Because of the conventional systems' modulation rates are lower, boiler thermal losses increase during pre-purge and post purge periods,
- Because of the conventional systems' modulation rates are lower, number of stop-starts will be more as a result of optimum time at low load decreases. It will cause increase on boiler thermal loss.
- Because of the conventional boilers are operated at higher flue temperatures, their efficiency values are lower.

According to these reasons, conventional boilers' operation time on the same system is higher.

Calculation Example:	Unit	Conventional Boiler	Condensing Boiler
System Capacity	[kcal]	2000000	2000000
Boiler Efficiency (80-60 °C)		0.9	0.98
Natural Gas Calorific Value	[kcal/m ³]	8250.0	8250.0
Hourly Gas Consumption	[m ³ /h]	269.4	247.4
	[h]	5.5	5.0
Daily Working Hours	[m ³]	1481.5	1236.9
Daily Gas Consumption Difference	[m ³]	244.6	
Gas Consumption Difference (150 days)	[m ³]	36693.5	

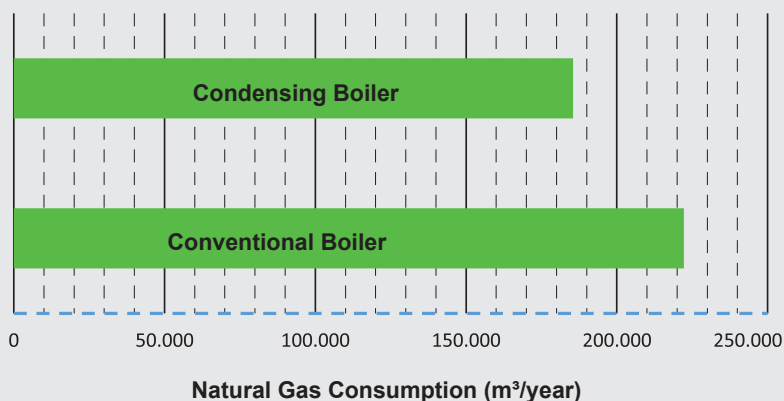

Optional Accessories

Product Image	Product Name	Specifications
	Outside Sensor	Operates between -50 °C and 70 °C. Max. distance 120 m with 1.5 mm ² cable. Tolerance ±1 K
	Clamp Type Temperature Sensor	Operates between -30 °C and 125 ° C. Max. distance 120 m with 1.5 mm ² cable. Tolerance ±0,5 K
	Immersion Type Temperature Sensor	Operates between 0 °C and 95 °C. Tolerance ±0,5 K.
	External Zone Module	Provides 3-way valve control function on temperature based zones. Requires additional relay and sensor connections.
	Room Thermostat	Provides room comfort temperature adjustment and working mode selection.
	Modbus Module	Provides Building Management Systems (BMS) connection.

Optional Accessories

Websserver



- Controlling and displaying possibility of the boiler system from anywhere via internet,
- Time program adjustments (heating circuit, DHW, external zone time program)
- Temperature adjustments of the heating circuits:
Such as DHW, swimming pool, solar energy, accumulation tank,
- Monitoring errors and error times in the system,
- Sending error messages up to 4 users,
- Checking cascade parameters,
- Setting holiday mode for heating circuits,
- Displaying maintenance periods and define the maintenance interval,
- Operating modes adjustment (economy, comfort, holiday and automatic operation)

Flue Lengths

DESCRIPTION	UNIT	WALLCON X-treme					
		42	50	67	115	125	150
B23	m	30	30	30	25	25	25
C13 - C33	m	15	15	15	20	18	17
C43 - C53 - C63 - C83	m	15	15	15	20	18	17

DESCRIPTION	UNIT	ALUCON					
		50	70	90	115	125	150
B23	m	25	25	25	25	22	22
C13 - C33	m	20	20	20	20	17	17
C43 - C53 - C63 - C83	m	20	20	20	20	17	17

NOTE: EFFECT OF 90° ELBOWS ON TOTAL FLUE LENGTH IS 1 METER.

Flue Application Details

Wallcon and Wallcon X-treme Flue Applications

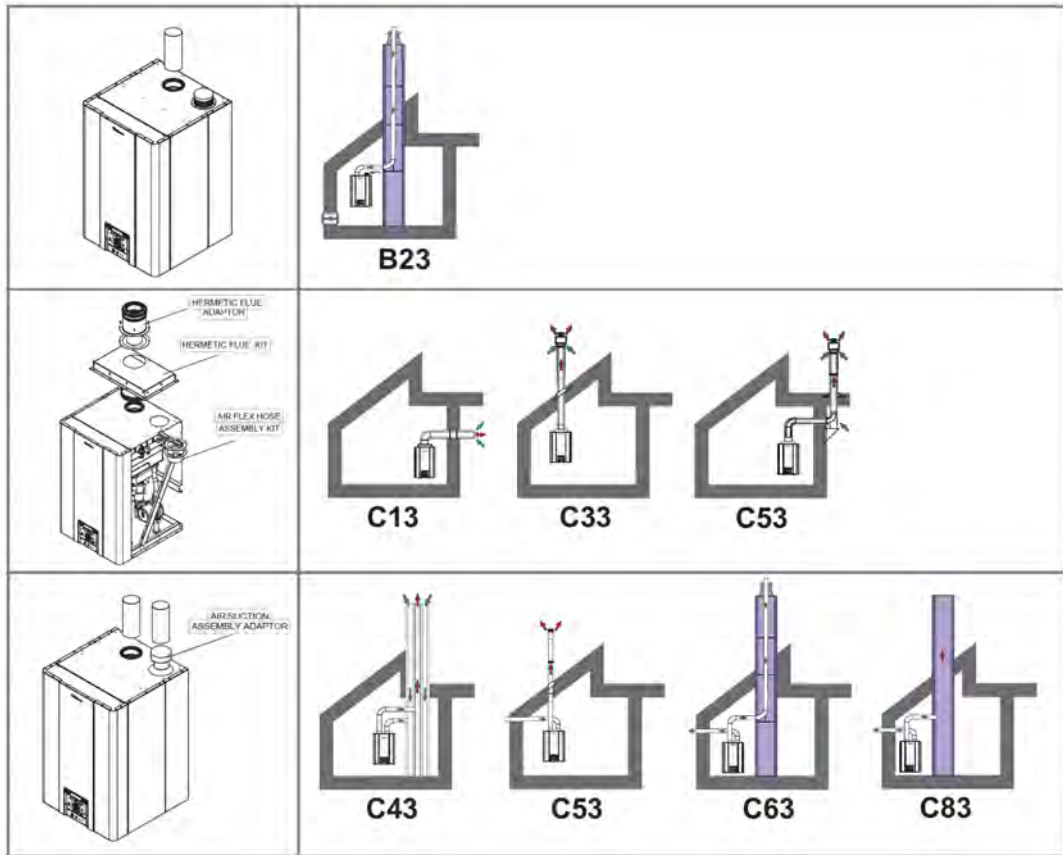

Alucon Flue Applications

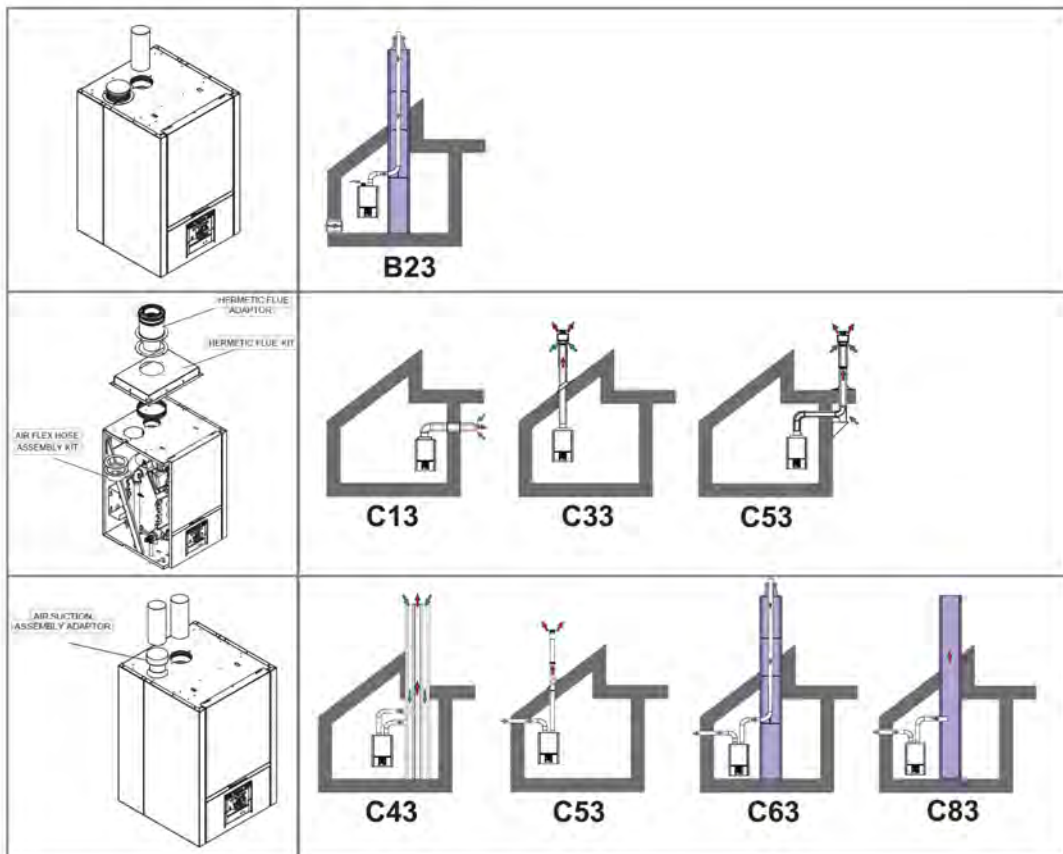

Installation Schemas

DHW + Radiator (Hydraulic Separator)

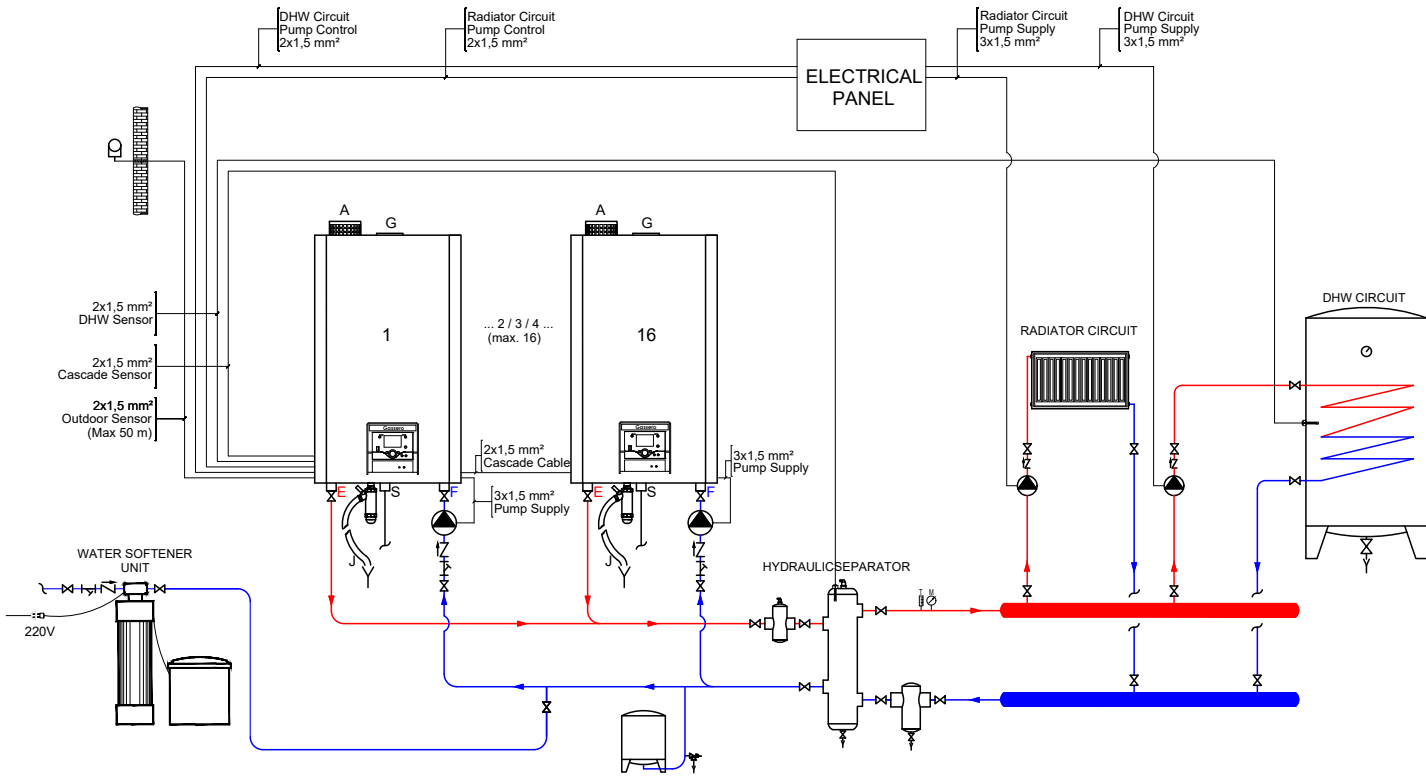

DHW + Radiator (Hydraulic Separator and 3 Way Valve)

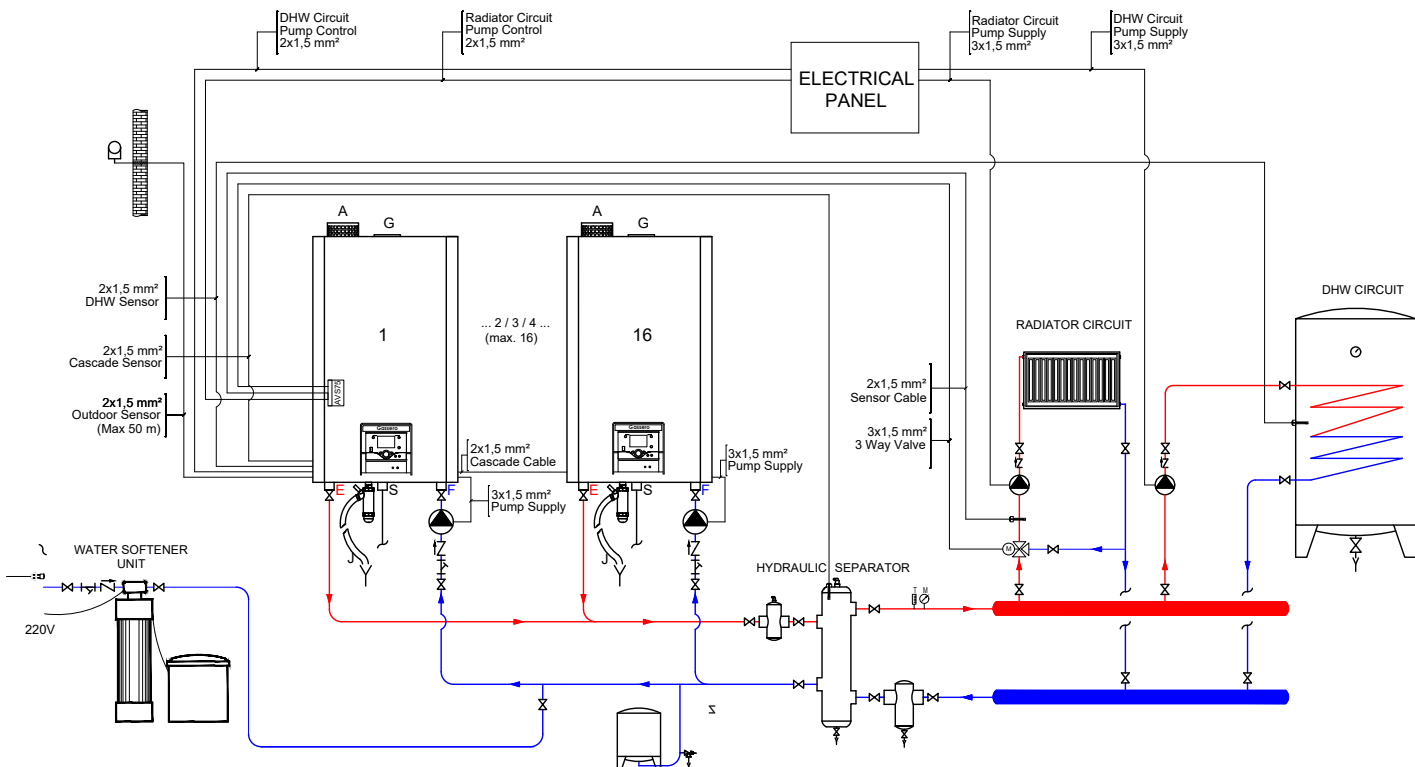

PUMP	VALVE	NON-RETURN VALVE	STRAINER	TEMPERATURE SENSOR	OUTDOOR SENSOR	AIR RELIEF VALVE	THERMOMETER	MANOMETER	SAFETY VALVE	DRAIN	AIR SEPARATOR	DIRT SEPARATOR	EXPANSION VESSEL

Installation Schemas

DHW + Floor Heating (Plate Heat Exchanger and 3 Way Valve)

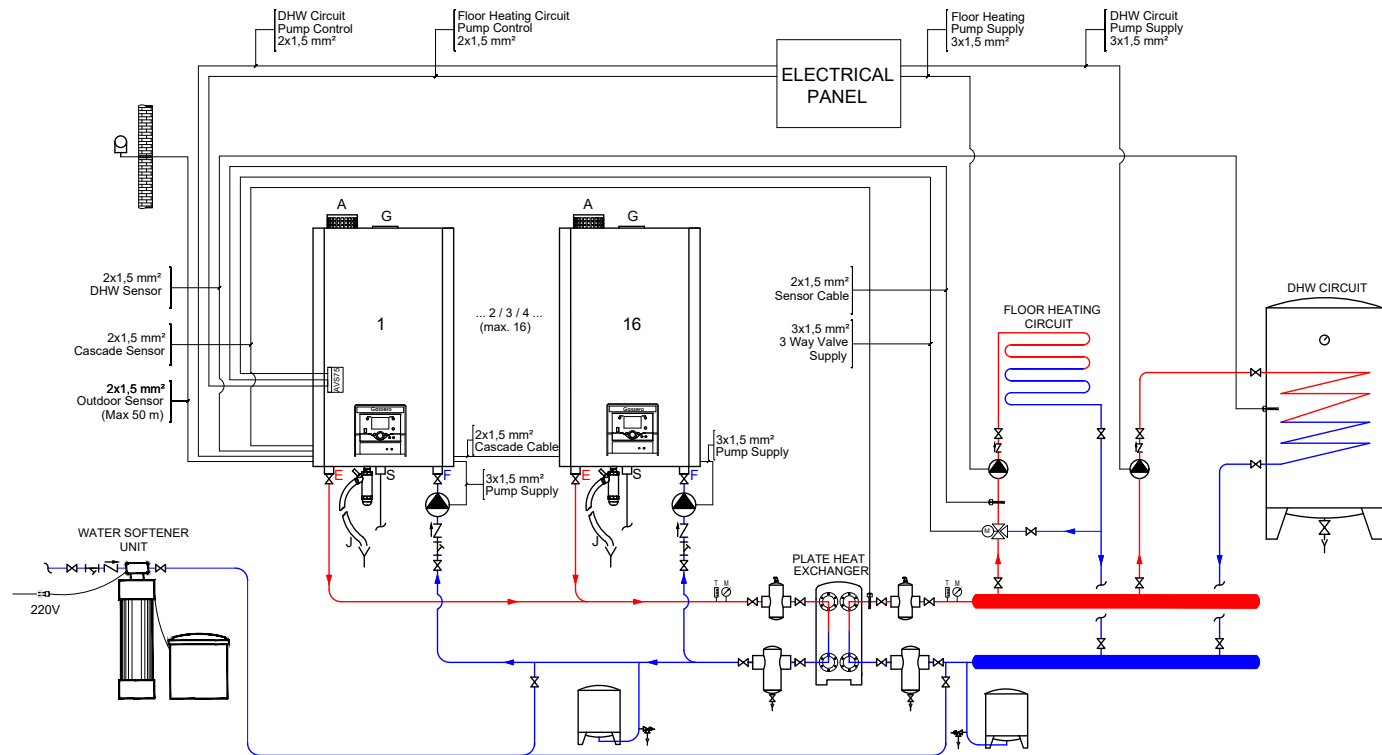

DHW + Floor Heating (Hydraulic Separator, Plate Heat Exchanger and 3 Way Valve)

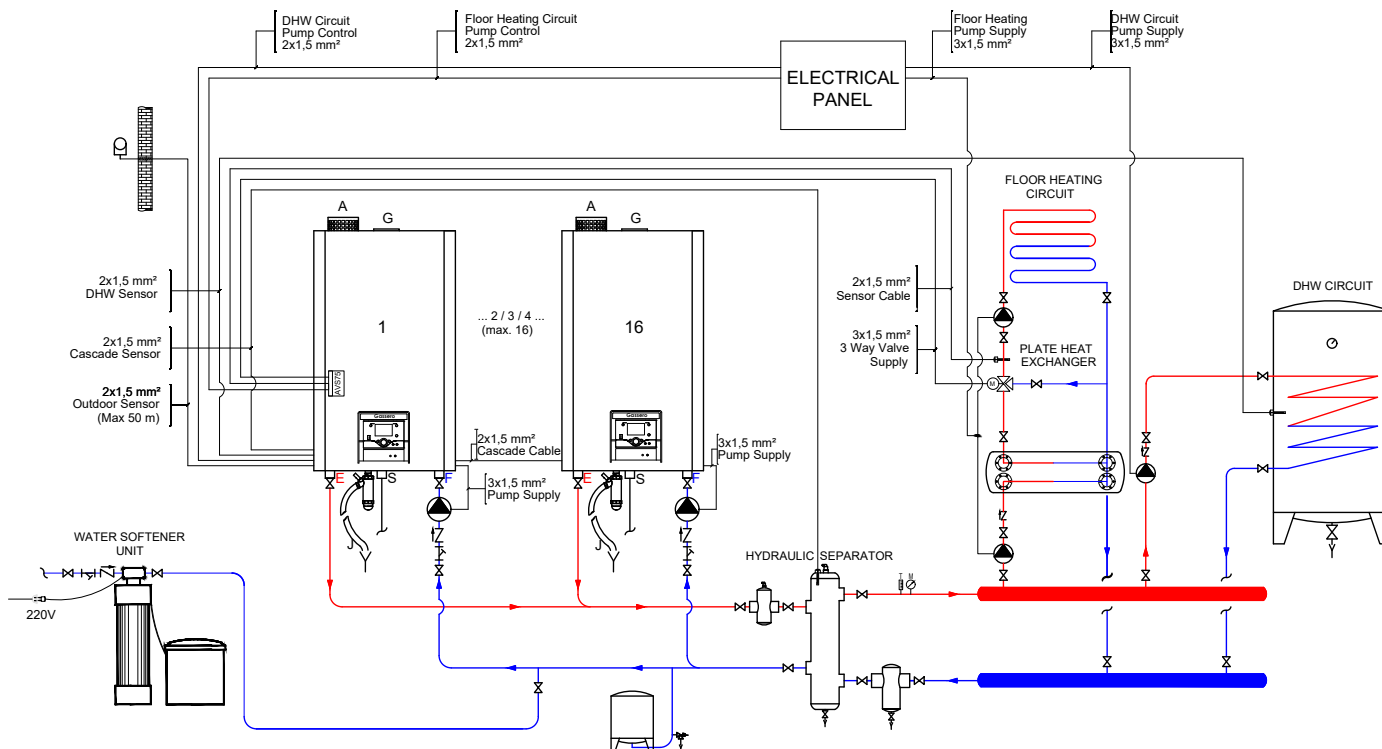

PUMP	VALVE	NON-RETURN VALVE	STRAINER	TEMPERATURE SENSOR	OUTDOOR SENSOR	AIR RELIEF VALVE	THERMOMETER	MANOMETER	SAFETY VALVE	DRAIN	AIR SEPARATOR	DIRT SEPARATOR	EXPANSION VESSEL

Installation Schemas

DHW + High Temperature Circuit + Radiator (Hydraulic Separator and 3 Way Valve)

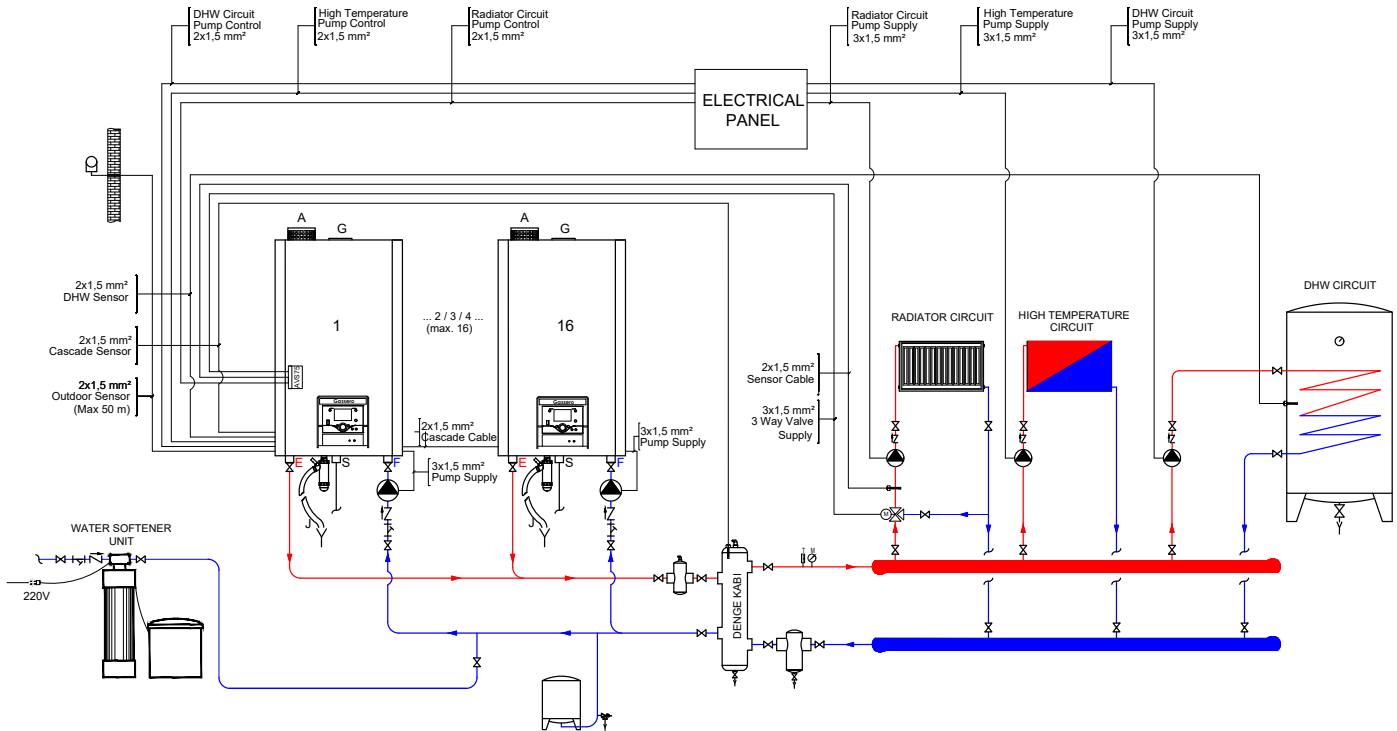

DHW + High Temperature Circuit + Radiator (Plate Heat Exchanger and 3 Way Valve)

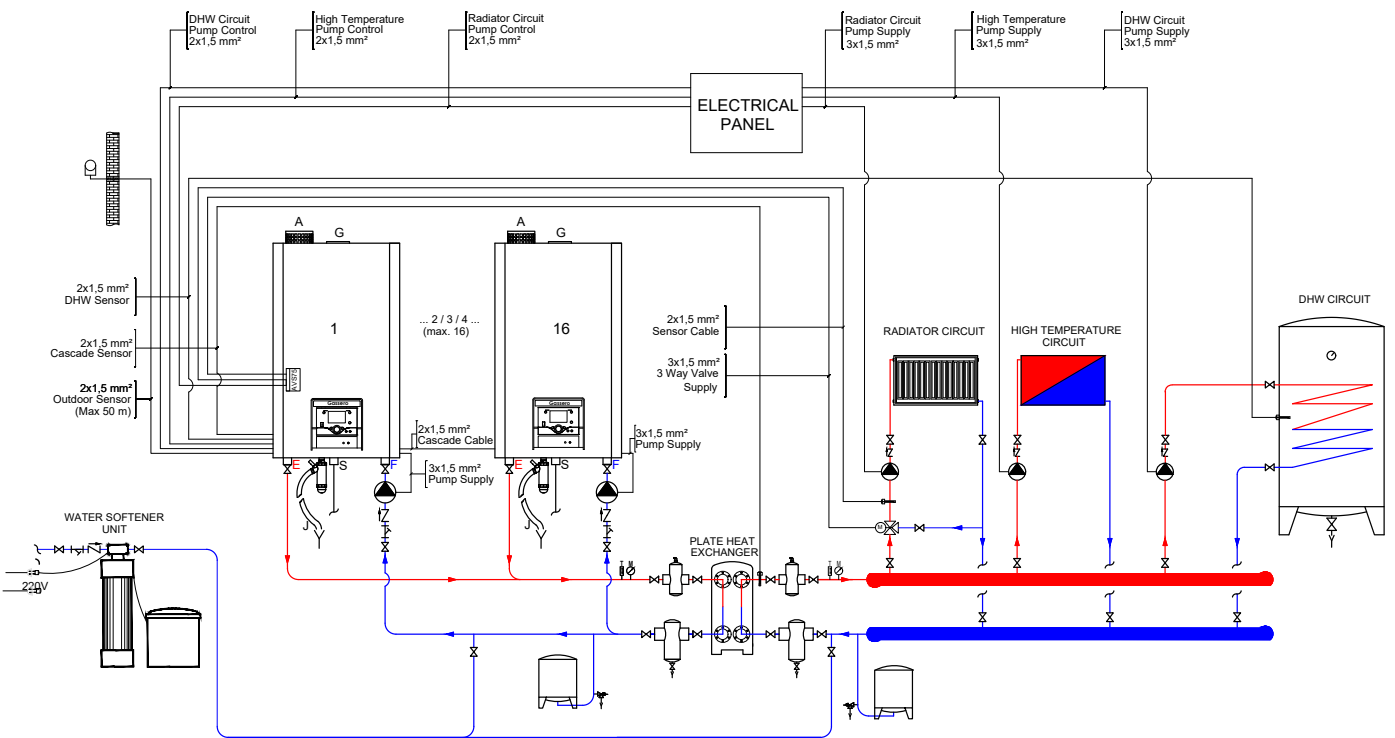

PUMP	VALVE	NON-RETURN VALVE	STRAINER	TEMPERATURE SENSOR	OUTDOOR SENSOR	AIR RELIEF VALVE	THERMOMETER	MANOMETER	SAFETY VALVE	DRAIN	AIR SEPARATOR	DIRT SEPARATOR	EXPANSION VESSEL

BOILER ROOM APPLICATION RECOMMENDATIONS

Gassero is strictly advising to use water softening unit before commissioning process for long term usage. Otherwise, system could harm because of undesirable substances.

It is highly recommended to use plate heat exchanger, if there is floor heating system on the heating line.

The devices that are commissioned outside of the required conditions, could be out of warranty.

Water Condition Range

Total Hardness °d	pH (Aluminium)	pH (Stainless)	Iron (Not Diluted)	Conductivity	Flushing
1	6,5-8,5	7,5-9,5	<10ppm	≤2000µS/cm	It is mandatory to comply with BSRIA 7593 (See: Gassero Flushing Process)

WATER CONDITIONS

Nitrite protection should not be used in boilers with aluminum heat exchangers

As GASSERO, we recommend flushing in the system to prolong the life of system and boilers. No acid-based products should be used during flushing.

The water used in the installation have to be city-water. **Never use well-water**

The boiler have to be serviced annually. All this maintenance should be made by authorized service, water values and the water softening unit (resin, salt etc.) values should be measured and maintained by service

Depending on the water conditions specified in the table, the problems that may occur in the boiler heat exchanger could make out of warranty.

Assembly and installation should made according to Gassero sample schemes.

HYDRAULIC

Boiler (primary) pump have to be selected to in accordance with the required pressure and flow rate.

The boiler (primary) pump have to be in the direction of the installation return line to the boiler.

The system operating pressure should match with the working pressure of boiler. Sales Engineers could give consultancy.

All heat exchanger manufacturers; recommends to use of plate exchanger instead of the hydraulic separator for separate the primary circuit and the secondary circuit.

Domestic waste system could be used for condensate water. In system with a total power of 200 KW and above, a neutralization tank must be used.

Boiler output and input diameters have to be strictly followed, other equipment should be selected according to the this diameters. In order to install other equipment, the diameter of the boiler out should not be reduced.

It is mandatory to use a suitable diameter filter and check valve to the boiler return line pipe at each boiler turn.

Please contact our service department about detail of collector connection in installation of floor type boiler.

Additional zone control modules and sensors have to be requested if there are equipment such as three-way valves and boilers that must be checked on the heating collector. Please contact our Sales Engineer for more information.

Have to be used air separator and dirt separator with hydraulic separator.

In case the plate heat exchanger is used instead of the hydraulic separator as the system separator, expansion tank have to be placed in the primary circuit. If an automatic filling valve is used in the system, a water meter have to be used for following how much water is added to the system.

In cascade systems, the sensor housing must be placed on the hydraulic separator or on the secondary flow line. If the system is separated by a plate heat exchanger, place the sensor housing on the secondary circuit flow line.

ELECTRIC AND FLUE

6A fuses have to be used for the power supply of the boilers. The electrical system must be grounded.

Chimney connections have to be made in accordance with the chimney types and regulations.

The flue gas analysis measuring probe (probe hole) have to be opened by the flue company for each boiler.

Boiler chimneys should be extended by a minimum 1 meter from the boiler flue outlet direction and then connected to the chimney collector without elbows or with elbows.

If the chimney connections passes over the boiler, the connections should be checked properly and water tightening should be provided. Water in the chimney due to leaks may cause the system out of warranty. Adequate ventilation should be provided for the boiler room.

GAS AND OTHER

The operating pressure of the boilers in the natural gas installation is 21 Mbar. Therefore, it is necessary to use a regulator in the gas line. There should be a minimum distance of 1-2 meters between the regulator and the boiler gas flange. There should be discharge line after regulator for discharge of the excess air.

In order to control the gas pressures, the manometer must be fitted before and after the regulator.

Gassero boilers are manufactured for heating and domestic water. Not suitable for commercial or industrial purposes. **GASSERO shall not be held responsible for any problems arising out of the design purpose.**

Distributed by



Hamilton

30 Gallagher Drive, Melville,
Hamilton 3026
Ph: 07 839 2705
E: tzhamilton@temperzone.com

Auckland

38 Tidal Rd, Mangere South,
Auckland 2022
Ph: 09 279 5250
E: nzsales@temperzone.com

Wellington

6 Union Street, Petone,
Lower Hutt 5012
Ph: 04 569 3262
E: wgtn@temperzone.com

Christchurch

40 Cass Street, Sydenham,
Christchurch 8023
Ph: 03 379 3216
E: chch@temperzone.com

www.gassero.com

Gassero
technology for your comfort

Gassero Isı Teknolojileri San. Ltd.

İstanbul Endüstri ve Ticaret Serbest Bölgesi (Free Zone)
4.Sokak No:8 34957 Tuzla / İstanbul
T: +90 (216) 394 09 85



Rev. 00 / 18.11.2019