

Product Highlights

2019

 IMI PNEUMATEX

 IMI TA

 IMI HEIMEIER



ENJOY MORE OF YOUR FREE TIME
THANKS TO OUR...

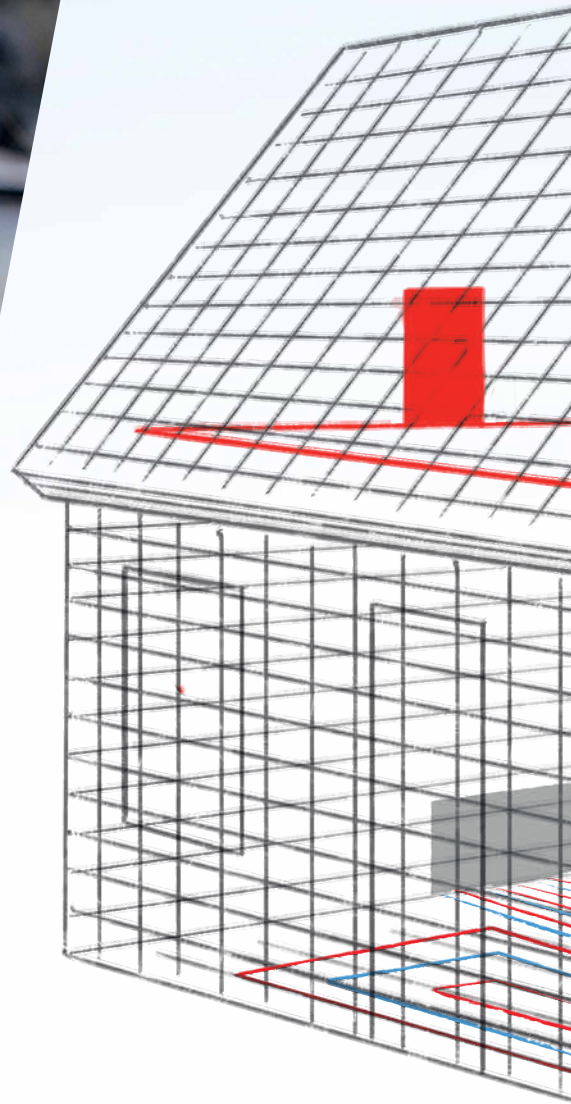

...SOLUTIONS FOR RESIDENTIAL PROPERTIES.

Halo Design Radiator Head

- Compact, chic and performant
- Ideal for hygienically sensitive installations
- Easy to fit and configure



Page 6

Zeparo Cyclone

- Cyclonic technology up to 9x more efficient in dirt removal than standard separators
- Protects critical equipment
- Available with magnets inside the insulation for high performance magnetite removal
- Horizontal and vertical mounting



Page 5

Simply Compresso

- Compact and reliable pressure maintenance system
- Plug & play installation
- Remote troubleshooting
- Easy maintenance



Page 4

Eclipse Technology for radiators & underfloor heating

- Optimally balanced system regardless of conditions
- Easy Flow Rate setting directly at the valve
- Automatic balancing with Automatic Flow Control (AFC) technology

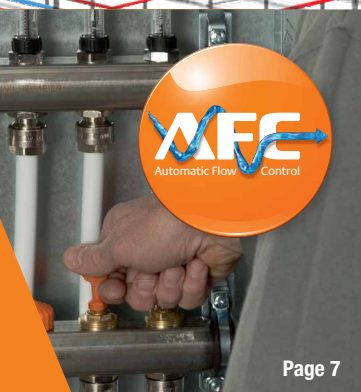



Page 7

EASE AND PERFORMANCE SIMPLY DELIVERED THANKS TO SIMPLY COMPRESSO

Simply Compresso is a tailored and cost effective solution for mid-size installations up to 400kW in heating capacity. It combines the greatest benefits from both static vessel and compressor pressurisation systems whilst delivering performance, space efficiency and easy installation.

- **80L vessel with pre-assembled compressor***
- **Plug & Play installation**
- **Remote troubleshooting via internet connection**
- **Easy maintenance**
- **No customer call-backs**

Ease & Simplicity

- One size fits all simplifies sizing selection and suits a wide range of applications 
- Plug & Play commissioning in 3-easy steps thanks to the BrainCube pre-configured system settings 
- The most compact and light solution available in the market 
- Simple 1-person installation by non-specialized installer

Peace of Mind

- Low maintenance & cost effective solution thanks to no yearly pre-pressure inspections needed
- Equipped with air-proof butyl bag 
- Vessel holds a 5 year warranty

Ultimate Performance

- BrainCube Connectivity for remote operation and troubleshooting via internet connection 
- *Supplementary 80L vessel can be integrated to expand system sizing to 160L
- The most silent compressor system in the market



38% SMALLER and LIGHTER than a static vessel



3-step Installation & Commissioning

Thanks to factory pre commissioning of the unit the process is very simple.

Installation

-  Connect unit to the heating system through a one-pipe connection
-  Plug in to a power supply
-  Start the BrainCube and follow instructions

Commissioning

-  Select the language
-  Confirm the BrainCube preconfigured system settings (standard for systems with a 3 bar safety valve). Manual adjustments for individual parameters are possible
-  Confirm the date & time of installation

Technical Data

	Simply Compresso
Application type	Buildings from 3 to 7 floor e.g. residential houses, supermarkets, kindergartens
Expansion volume	80L with supplementary vessel up to 160L
Application power	For heating systems up to 400 kW and cooling systems up to 600 kW
Space Saving	Yes
Max Pressure	3 bar
Accuracy	±0.1 bar
Remote control	Yes

HIGHER HVAC SYSTEM RELIABILITY FOR YOUR CUSTOMER, FULL INSTALLATION FLEXIBILITY FOR YOU **THANKS TO ZEPARO CYCLONE**

The Zeparo Cyclone removes dirt and magnetite in heating and cooling systems much more quickly, easily and efficiently than ever before.

The new standard for dirt separation is based on cyclonic technology, which revolutionises the HVAC system maintenance due to its highly superior capacity for dirt removal.

Capable of being fitted both horizontally and vertically



Insulation with built-in magnets



Higher Performance

- Up to 9x higher efficiency dirt separation than standard separators
- Insulation with high performance magnet, improves removal of magnetite dirt particles up to 50%
- Can be flushed whilst in operation (unlike filters)

HVAC system protection helps save unnecessary costs

- Protects critical equipment (boilers, pumps, valves) from the harmful effects of dirt
- Lowers energy costs by removing dirt which affects circulation and heat transfer e.g. in radiators
- Reduces maintenance costs and equipment failure

Available in dimensions DN20 to DN50



ZCD
DN 20

ZCD
DN 25

ZCD
DN 32

ZCD
DN 40

ZCD
DN 50

ZCHM
DN 20 - 50

Technical data

High efficiency due to Cyclonic technology

Performs well at high temperatures up to 110°C due to special inner part compound (PPS)

High efficiency independent of dimension, positioning or high-flow rates

Inline construction for easy installation and maintenance

PN10 Pressure rating

3/4" version can be directly connected to copper pipes (15, 18 and 22mm) with a compression coupling

Unique magnet and insulation combination accessory can be easily mounted on existing cyclone installations

SMART LOOKS FOR YOUR CUSTOMER – SIMPLICITY AND PEACE OF MIND FOR YOU **THANKS TO HALO**

The Halo TRV Sensor continues our long tradition of superbly-designed and engineered products that are easy to fit, simple to configure and energy efficient.

Your style-conscious customers get what they want - the elegance today's interiors demand - and you can fit it, set it and forget it, confident in the knowledge that you're providing long-term performance and customer satisfaction.



*Available in cool white
and stylish chrome finish*

Excellent looks and performance

- Halo's enclosed design with no steps or gaps prevents dust build-up and is ideal for bathrooms, kitchens or any other hygienically sensitive installations
- Renowned IMI HEIMEIER technology ensures long-term performance
- Liquid-filled thermostat delivers minimal hysteresis and stable temperature control
- Lockable controls help ensure optimal settings are maintained for greater energy efficiency
- Perfect for newly commissioned installations and ideal for renovation projects

Sophisticated style and technology

- Smaller than the average TRV Sensor but packed with innovative design features
- Easy to fit and configure; satisfying your customers' aesthetic demands has never been easier
- Guaranteed performance and peace of mind to reduce customer call backs and protect your valuable time
- Energy-efficient thermostatic control has never looked so good

Easy installation

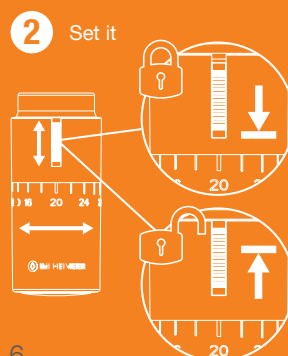
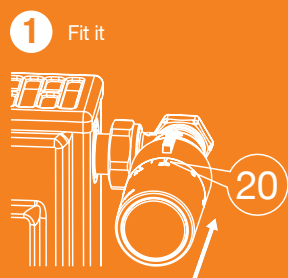

Technical Data

	Halo
Applications	Radiator heating system – particularly suitable for decorative and hygienic environments
Control behaviour	Proportional controller without auxiliary energy. Liquid-filled sensor. Stable control even in small p-band variation (<1K)
Nominal temperature range	0°C – 28°C 6°C – 28°C
Connection	Designed for all IMI HEIMEIER thermostatic valve bodies and radiators with integrated valves incorporating M30x1.5 thermostatic inserts

PROVIDE GREATER COMFORT FOR YOUR CUSTOMERS AND TAKE THE TROUBLE OUT OF YOUR INSTALLATIONS **THANKS TO ECLIPSE AFC TECHNOLOGY**

Achieving peak performance through hydronic balancing can be both time consuming and complex. With Eclipse Automatic Flow Control (AFC) technology that complexity has been eliminated. Hassle-free installation is now available for both radiator solutions and underfloor heating systems.

Our Eclipse range of products provides a quick and efficient route to a perfectly balanced and highly energy efficient system. And the automatic flow control prevents overflows and ensures your customer comfort.

Bringing simplicity to your installations

- No complex calculations necessary
- Quick and easy to install, just 10 seconds to set the flow
- It is set with a simple turn of a key
- Time and cost-saving commissioning solution

Comfort for your customers

- Ensures an automatically balanced system, regardless of load changes
- Flow rates easily adapted to given heating loads



Eclipse
Thermostatic radiator valves & valve inserts



Dynacon Eclipse
Underfloor heating manifold & inserts



Automatic hydraulic balancing



Perfect for renovation



Time-saving installation and hydronic balancing



Flow rate setting directly at the valve

Automatic Flow Control (AFC) technology: How it works

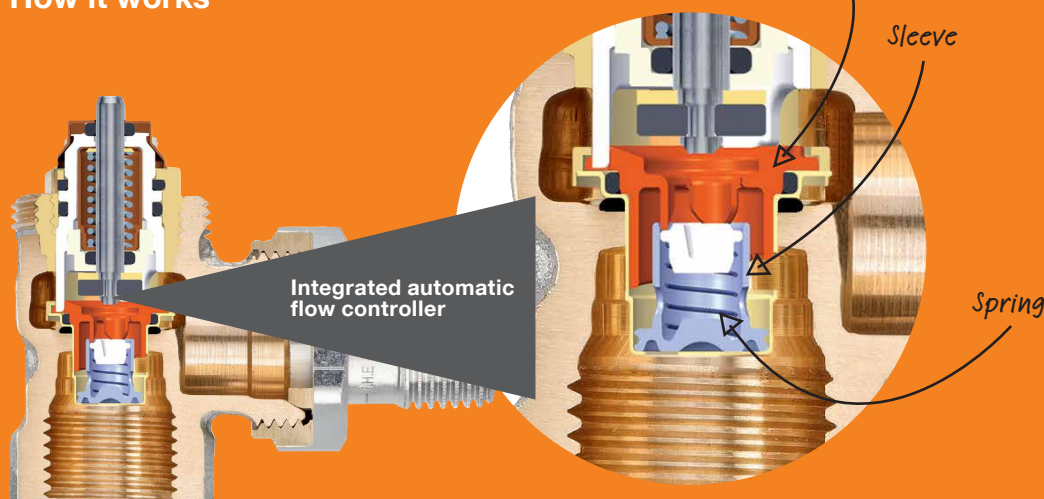

- The lift of the control cone is set to the calculated flow rate by using the setting key to adjust on the valve itself.
- Increased flow rate leads to a corresponding pressure increase causing the sleeve to move. The maximal flow is always limited, the flow to the set value and can never be exceeded.
- If the flow rate drops below the set maximum value, the spring presses the sleeve back into its initial position.



Connected, flexible and efficient

LIKE ME.

SOLUTIONS FOR COMMERCIAL PROPERTIES

Innovative and connected products for smart building control, which help you to more easily and flexibly design, install and maintain your installations

Zeparo G-Force

- High performance dirt separator for larger applications
- Unique horizontal or vertical installation
- Protects & extends the lifetime of your HVAC system
- Reduces maintenance costs & risk of equipment failure

Page 11

TA-Slider & TA-Modulator

- Accurate and flexible controls solution (linear actuator + PIBCV)
- Versions for analogue or BUS communication systems
- Efficient digital configuration that can help you save up to 50% of commissioning time

Page 12

Brain Cube Connect

- Convenient remote control 24/7 of the pressure maintenance equipment
- Troubleshooting & commissioning support
- Communication with the BMS

Page 10

Changeover solution

- Flexible and performant solution for 4-pipe combined heating & cooling systems
- The "click and connect" feature of the TA-Slider 160 CO enables effortless integration with the rotary actuator of the TA-6-way valve
- Digital configuration for easy balancing, commissioning, troubleshooting & diagnostics

Page 13

STAY IN CONTROL ANY TIME, FROM ANYWHERE, WITH BRAINCUBE CONNECT



Connected interface

The BrainCube technology allows total visibility and remote access to system information via any connected device or via the Building Management System (BMS).

Seamless integration

The BrainCube integrates with the BMS (Modbus and IMI Pneumatex protocol) KNX or BACnet networks through standardised Ethernet, RS485 adapters or direct connection via USB.

E.g. If a system fault is detected, an alert will be sent directly to your smartphone. You can access the system settings, make adjustments and even troubleshoot it before the problem gets worse.

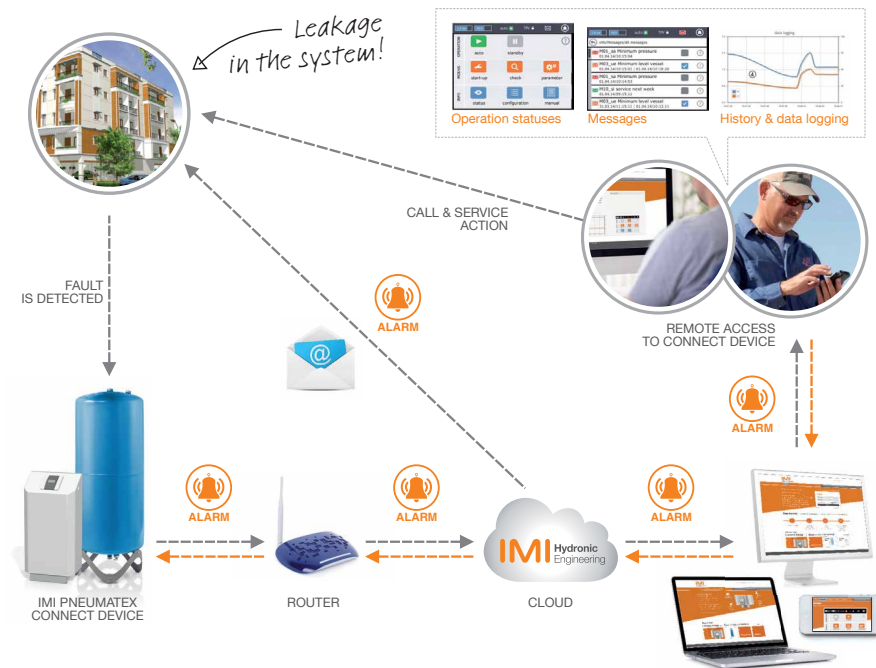

Product range

The unique BrainCube technology is integrated as standard into a wide range of our products. So, whether your project is a commercial building or a skyscraper, IMI Pneumatex has a high-performing and connected pressure maintenance solution for you.

	Pressurisation Solutions				Ancillary products	
System type	Dynamic air cushion systems - with compressors		Dynamic air cushion systems - with pumps		Pressure control and water make-up	Vacuum degasser
	For medium to large-sized applications (up to 20Mw) . Optimal pressure is maintained by a compressor and overflow valve.		For medium to large-sized applications (up to 160Mw) . Optimal pressure is maintained by a pump and overflow valve.		The «fillsafe» electronically monitors and controls the water make-up and ensures maximum safety	Highly efficient cyclonic vacuum degassing, including of the make-up water.
Products	Compresso Connect F	Compresso Connect	Transfero TV Connect	Transfero TVI Connect	Pleno	Vento Connect
Product Features						
Volume	from 140L to 800L	from 200L to 5000L	from 200L to 5000L	from 140L to 5000L	Up to 1.4m ³ /h flow output (for 9bar)	Up to 1000L/h flow capacity
Pressure Class	5.5 bar	9 bar	10 bar	20 bar	Up to 10bar	Up to 20.5bar

CLEAN YOUR SYSTEM UP TO 9X MORE EFFICIENTLY BEFORE DIRT DEPOSITS IN CRITICAL HVAC EQUIPMENT WITH ZEPARO G-FORCE

Zeparo G-Force is a dirt and magnetite separator suitable for larger applications (DN65 to DN300). Thanks to its unique separation method using **cyclonic technology** it is up to 9x more efficient* helping to clean your system in fewer cycles, protecting its components and ensuring their longevity.

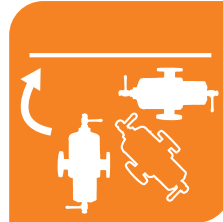

Why is dirt separation so important?



Dirt build-up from construction or generated due to oxygen ingress will travel through the system and ultimately accumulate in system components resulting in higher energy consumption, malfunctions and expensive repairs on equipment such as boilers, pumps and valves. Therefore, it is critical to remove dirt as quickly as possible.

How does the Zeparo G-Force dirt separator work?

- The cyclonic effect generates centrifugal forces that push even the smallest dirt particles towards the Zeparo's outer walls.
- The dirt particles with deposit in the chamber so they can easily be flushed out – even whilst the system is still running.
- Unlike other dirt separators on the market, the Zeparo G-Force's efficiency increases with the water velocity; **offering exceptional protection even in systems with higher flows.**

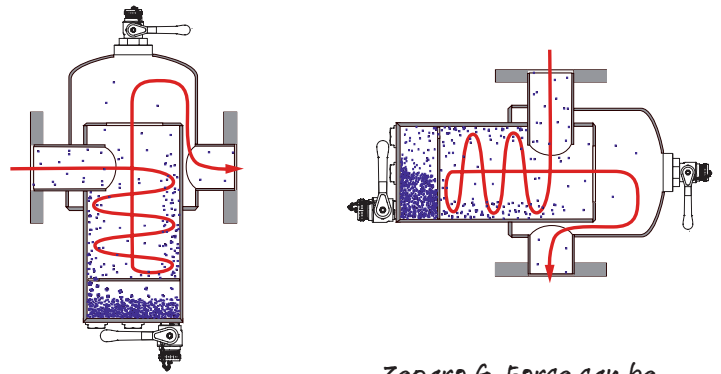

Zeparo G-Force can be mounted either horizontally or vertically in any position

Speed of Dirt Removal vs. Dirt Accumulation

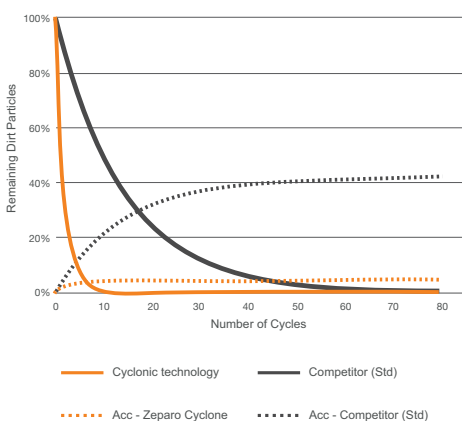

Measured Separation Efficiency against Competitors*

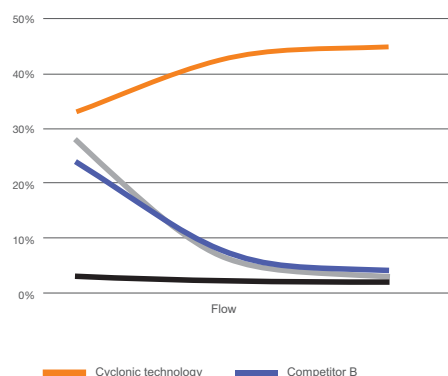

* Performance measured by Institut für Umwelt- und Verfahrenstechnik UMTEC, Rapperswil, Switzerland

SMART DIGITAL CONTROL WITH TA-SLIDER & TA-MODULATOR



TA-Slider

Linear actuator that gives you greater flexibility in design, control and installation.

Complete range available with versions for analogue or BUS communication systems.



Together, TA-Slider & TA-Modulator, enable up to 6x higher operating stroke for outstanding control accuracy, even for small flows

TA-Modulator

Highly precise pressure independent balancing & control valve (PIBCV) for proportional or 3-point control

Save Time



Efficient digital configuration via a smartphone, or through the BMS, helps you save up to 50% of commissioning time.



10 times more setting parameters for better on-site adaptability to real system conditions.

Save Energy



Accurate modulating control reduces temperature oscillations and pumping costs helping to reach up to 18% annual energy savings.



Accurate control ensures only the necessary amount of energy is delivered to reach the desired room temperature.

Typical Applications

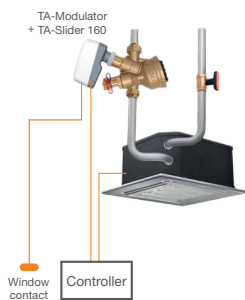

Fan-coils

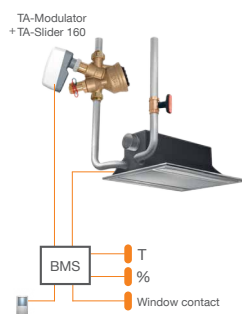

Chilled beams

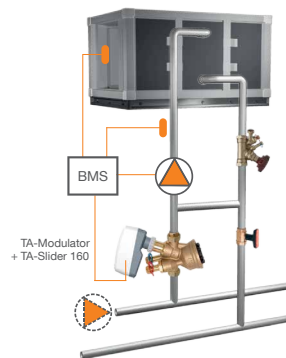

Air handling units

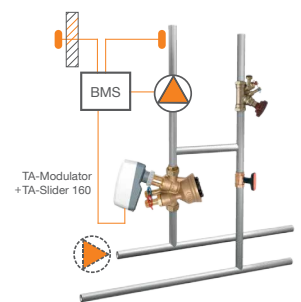

Pressure independent mixing circuits

Product Compatibility

TA-Slider 160 + TA-Modulator DN15-32



TA-Slider 500 + TA-Modulator DN40-50



TA-Slider 750 + TA-Modulator DN65-80



HIGHLY PRECISE & FLEXIBLE CONTROL EASILY INSTALLED AND CONFIGURED WITH OUR CHANGEOVER SOLUTION



Especially adapted package for 4-pipe combined heating & cooling systems

TA-Slider 160 CO is specifically designed for changeover systems with a «click & connect» feature for effortless electrical connection to the **TA-M106 CO** actuator controlling the **TA-6-Way valve**.

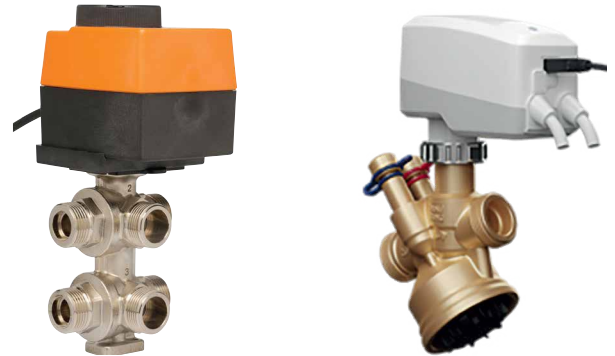

Digital Configuration via Smartphone

Digital configuration enables quick and easy set-up of the control parameters for precise modulating control between the cooling and heating network.

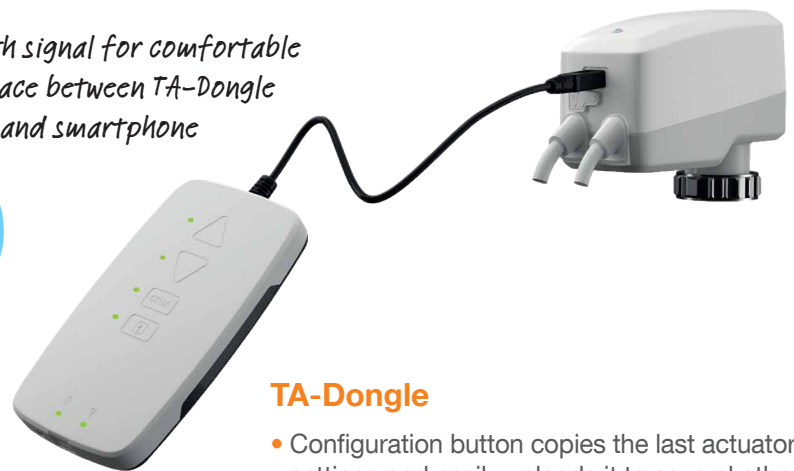
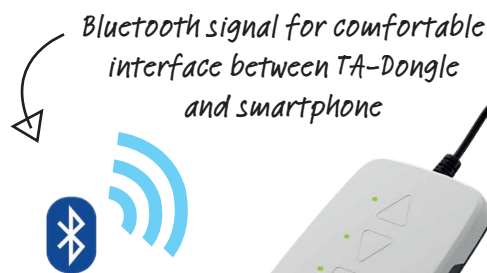

TA-Dongle

- Configuration button copies the last actuator settings and easily uploads it to several other actuators – helping to save up to 50% of commissioning time
- Internal battery allows setup of actuator in all circumstances, even without power supply

HyTune App

- Intuitive and easy to use
- Enables comfortable set-up of TA-Slider even on hard to reach or poorly lit environments

Typical Applications

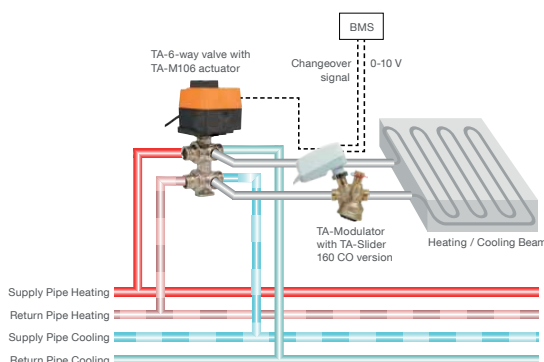

Changeover solution with two control signals and Beam Terminal Unit

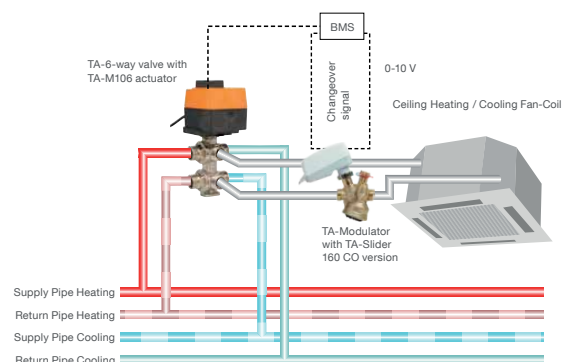

Changeover solution with three control signals and Fan-coil Terminal Unit



SOFTWARE AND APPS

A range of Planning & Calculation Tools that put you in control

Whether you are designing a system from scratch or looking to improve the performance of existing installations, we have the application and software to help you.

HySelect

Everything you need to design, optimise and control a hydronic system in one software.



HySelect helps you create and control your hydronic system from the design stage right through to commissioning; simply input pipe lengths, terminal unit design flow and differential pressure to create an optimal system design.

The software communicates with the TA-SCOPE balancing instrument to help you quickly and easily confirm that system commissioning matches the original design and delivers the required performance. It couldn't be easier to upload or download system information to and from the TA-SCOPE and speed up the balancing and monitoring process.



You can download the HySelect software on our website 



HyTools

All-in-one app for hydronic calculations

HyTools is packed with expert hydronic data to simplify complex calculations such as product and pipe sizing, unit conversion, flow, Dp, Power and valve setting calculations.

Achieving ideal system balancing, optimal pressurisation and energy-efficient thermostatic control is just a few clicks away with your smartphone.

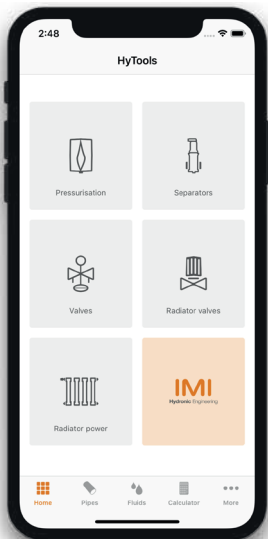

HyTools is available from the Apple App Store or Google Play

Downloadable Plugins

Exportable BIM models for:

- Datanorm
- MagiCAD
- MagiCAD Cloud
- VDI Datensatz
- Revit (via Plugin)

Available on our website or on the MagiCloud website

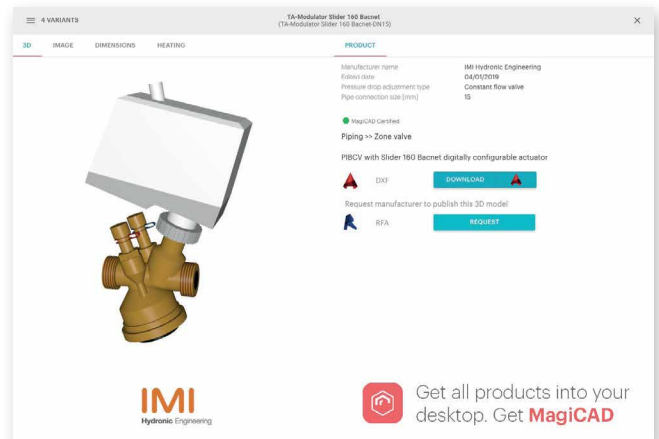

Distributed by



Hamilton

30 Gallagher Drive, Melville,
Hamilton 3026
Ph: 07 839 2705
E: tzhamilton@temperzone.com

Auckland

38 Tidal Rd, Mangere South,
Auckland 2022
Ph: 09 279 5250
E: nzsales@temperzone.com

Wellington

6 Union Street, Petone,
Lower Hutt 5012
Ph: 04 569 3262
E: wgtn@temperzone.com

Christchurch

40 Cass Street, Sydenham,
Christchurch 8023
Ph: 03 379 3216
E: chch@temperzone.com

**IMI Hydronic Engineering
International SA**

Route de Crassier 19
1262 Eysins, Switzerland
www.imi-hydronic.com

IMI

Hydronic Engineering