



User Guide

Babel Buster 2

Model BB2-7010
BACnet Modbus Gateway
Rev. 1.3 – Oct. 2015

© 2015 Control Solutions, Inc.

BB2-7010 User Guide Contents

- [1 Introduction](#)
 - 1.1 How to Use This Guide
 - 1.2 Overview of Gateway Devices
 - 1.3 Important Safety Notice
 - 1.4 Warranty
- [2 Connecting BB2-7010 for the First Time](#)
- [3 Minimum BB2-7010 Gateway Setup](#)
- [4 Using the BB2-7010 as a BACnet Server](#)
- [5 Configuring BB2-7010 as a Modbus RTU Master](#)
 - 5.1 Modbus RTU Device Configuration
 - 5.2 Modbus RTU Master Read Maps
 - 5.3 Modbus RTU Master Write Maps
 - 5.4 Modbus RTU Master Data Displayed Per Slave
 - 5.5 Modbus RTU Errors
- [6 Configuring BB2-7010 as a Modbus TCP Client](#)
 - 6.1 Modbus TCP Device Configuration
 - 6.2 Modbus TCP Client Read Maps
 - 6.3 Modbus TCP Client Write Maps
 - 6.4 Modbus TCP Errors
- [7 Using the BB2-7010 as a BACnet Client](#)
 - 7.1 BACnet Device Configuration
 - 7.2 BACnet Client Read Maps
 - 7.3 BACnet Client Write Maps
 - 7.4 BACnet Errors
- [8 Modbus RTU Slave Configuration](#)
 - 8.1 Modbus RTU Device Configuration
 - 8.2 Modbus RTU Slave Register Mapping
- [9 Modbus TCP Server Configuration](#)
 - 9.1 Modbus TCP Device Configuration
 - 9.2 Modbus TCP Register Mapping
 - 9.3 Modbus Virtual Device Register Mapping
- [10 SNMP Server Configuration](#)
 - 10.1 Local SNMP MIB
 - 10.2 Trap Thresholds
 - 10.3 SNMP Trap Destinations
- [11 SNMP Client Configuration](#)
 - 11.1 SNMP Device Configuration
 - 11.2 SNMP Client Read Maps
 - 11.3 SNMP Client Write Maps
 - 11.4 SNMP Errors
- [12 HTTP Client](#)
- [13 BBMD Setup](#)
- [14 Object Properties](#)
 - 14.1 Data Object Properties (Analog, Binary, Multi-state)
 - 14.2 Device Object Properties
- [15 Trouble Shooting](#)
- [16 WiFi Sensor Setup - PointSix, AirTest](#)
 - 16.1 Sensor Network Settings

- 16.2 Configuration
- 16.3 Sensor Data Page

17 WiFi Sensor Setup - Veris Industries

- 17.1 Sensor Network Settings
- 17.2 Configuration
- 17.3 Sensor Data Page

18 WiFi Sensor Setup - Functional Devices RIB

- 18.1 Sensor Network Settings
- 18.2 Configuration
- 18.3 Sensor Data Page
- 18.4 Sensor Diagnostic Page

Appendix A Hardware Details

- A.1 Wiring
- A.2 Front Panel LED Indicators
- A.3 RS-485 Line Termination and Bias



1. Introduction

1.1 How to Use This Guide

The first few sections of this user guide provide background information on how the gateway works, and an overview of the configuration process. The next several sections are guides for each of the tabs found in the web interface in the gateway which is accessed by opening a web browser and browsing to the IP address of the device.

You should at least read the overview sections to gain an understanding of how the gateway functions. You can use the remaining sections as reference material to look up as needed. There is a "Quick Help" section at the bottom of each web page in the gateway which is generally sufficient for quick reference in setting up the gateway.

1.2 Overview of Gateway Devices

The Babel Buster BB2-7010 is a BACnet to Modbus gateway. It may be used as BACnet IP client and server, Modbus TCP client and server, and Modbus RTU master or slave. The BB2-7010-02 may also be used as SNMP client and server. The BB2-7010-06, -07, and -08 models add gateway capability for specific types of WiFi sensors (see section 16, 17, 18).

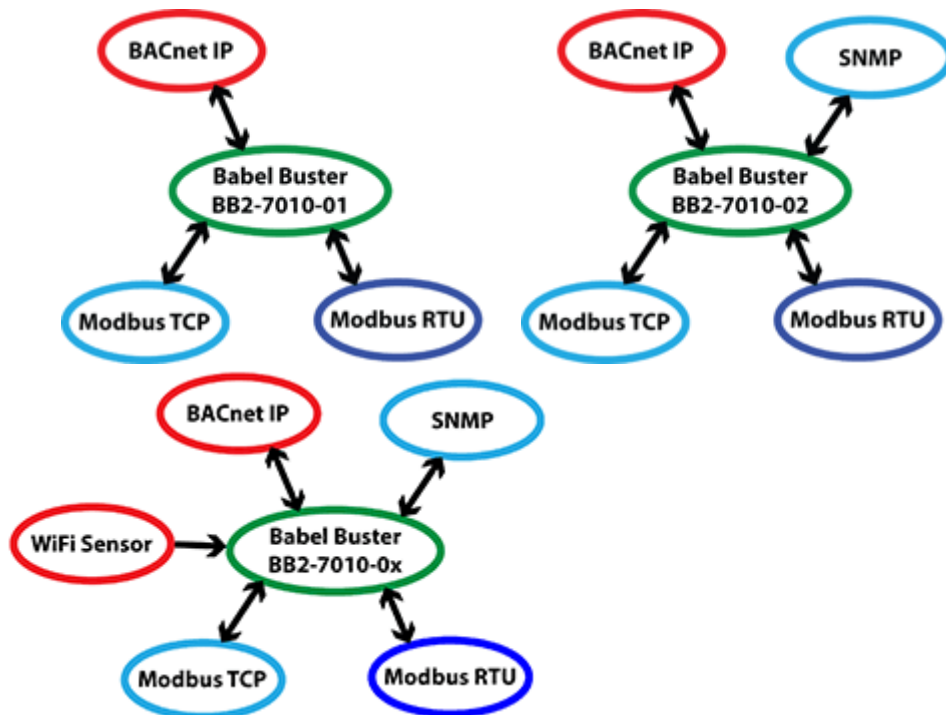

The most common application for the BB2-7010 is interfacing a Modbus RTU device to a BACnet IP network. The BB2-7010 will automatically poll the Modbus RTU device, and store the content if its

registers in BACnet objects you assign. The BACnet system may then use standard BACnet services such as Read Property to access the content of the Modbus registers. The BB2-7010 will also accept COV subscriptions such that other devices will receive a COV notification when the content of a Modbus register changes.

The BB2-7010 can be also configured as a Modbus RTU slave. This is useful when a PLC wants to write data to the BB2-7010, thereby making the PLC's data available as BACnet object properties.

The BB2-7010 can be configured as a BACnet IP client. This means the BB2-7010 will be reading and writing properties in other BACnet devices, storing copies of their object's Present Value in the BB2-7010. The stored values may later be accessed by Modbus or SNMP.

1.3 Important Safety Notice

Proper system design is required for reliable and safe operation of distributed control systems incorporating any Control Solutions product. It is extremely important for the user and system designer to consider the effects of loss of power, loss of communications, and failure of components in the design of any monitoring or control application. This is especially important where the potential for property damage, personal injury, or loss of life may exist. By using ANY Control Solutions, Inc., product, the user has agreed to assume all risk and responsibility for proper system design as well as any consequence for improper system design.

1.4 Warranty

This software and documentation is provided "as is," without warranty of any kind, either expressed or implied, including, but not limited to, the implied warranties of fitness or merchantability for a particular purpose. Control Solutions may make improvements and/or changes in this documentation or in the product(s) and/or the program(s) described in this documentation at any time. This product could include software bugs, technical inaccuracies, typographical errors, and the like. Changes are periodically made to the information herein; these changes may be incorporated in new editions of the software.



2. Connecting the BB2-7010 for the First Time

Follow these steps to make the initial connection to the BB2-7010.

(a) Connect power. Apply +12 to +24VDC or 24VAC to the terminal marked "POWER", and common or ground the the terminal marked "GND".

(b) Connect a CAT5 cable between the RJ-45 jack on the top and your network switch or hub. You cannot connect directly to your PC unless you use a "crossover" cable.

(c) Apply power. A blue LED inside the case should light indicating power is present. If the yellow LED on the RJ45 jack is not on, check your Ethernet cable connections. Both green and yellow LEDs on the RJ45 jack will be on solid for a time during boot-up. The entire bootup process will take 1-2 minutes, during which time you will not be able to connect with a browser.

(d) The default IP address as shipped is 10.0.0.101. If your PC is not already on the 10.0.0.0 domain, you will need to add a route on your PC. Do this by opening a command prompt. First type "ipconfig" and note the IP address listed. This is your PC's IP address. Now type the command

```
route add 10.0.0.0 mask 255.255.255.0 1.2.3.4
```

but substitute your PC's IP address for 1.2.3.4.

This generally works, but if this fails, you will need to temporarily change your computer's IP address to a fixed address that starts with 10.0.0. and ends with anything but 101.



[BACnet Object Property Summary](#)

[Hardware Guide](#)

[System Capacity Summary](#)

[Modbus Slave Register Mapping](#)

[Trouble Shooting](#)

[Modbus Notes](#)

Model BB2-7010-01
v2.34.5

Quick Help

Click any tab above to log in. If you are not already logged in, you will be asked for your user name and password. You will need these in order to log in.

To log out, simply close your browser. IMPORTANT: If you have made configuration changes that you want to save permanently, go to the System->Setup->Config File page and click "save". Changes made by clicking "update" are only temporary until you save changes permanently in your configuration file.

(e) Open your browser, and enter "http://10.0.0.101/" in the address window. You should see a page with the "Babel Buster BB2-7010" header shown above. From this point, you will find help on each page in the web site contained within the product.

(f) When you click on any of the page tabs such as System Setup, you will be asked for a user name and password. The default login is user name "system" with password "admin". You can also log in as "root" using password "buster". You should log in as "root" if you will be changing the IP address.

Babel Buster 2
BACNET-MODBUS
NETWORK GATEWAY
MODEL BB2-7010-01

CONTROL SOLUTIONS, INC.
MINNESOTA

Data Objects | Modbus | BACnet | **System Setup**

Setup | HTTP Client

Config File | **BACnet IP Port** | BBMD | Local Host | User

This page allows you to change this device's IP address, and select whether double registers are swapped when returned to a remote client accessing this server.

IP Address	<input type="text" value="192.168.1.64"/>	192.168.1.64	<input type="button" value="Review IP"/>
Subnet Mask	<input type="text" value="255.255.255.0"/>	255.255.255.0	<input type="button" value="Change IP"/>
Gateway	<input type="text" value="192.168.1.1"/>	192.168.1.1	

(g) To can change the IP address of the BB2-7010, go to the Local Host page under System :: Setup. The following page should appear. Change the IP address, and subnet mask and gateway if applicable. Click Change IP to save the changes. The process of programming this into Flash takes around half a minute. The new IP address only takes effect following the next system restart or power cycle.

Babel Buster 2
BACNET-MODBUS
NETWORK GATEWAY
MODEL BB2-7010-01

CONTROL SOLUTIONS, INC.
MINNESOTA

Data Objects | Modbus | BACnet | **System Setup**

Setup | HTTP Client

Config File | **BACnet IP Port** | BBMD | Local Host | User

This page allows you to manage configuration files.

Store configuration to Flash file selected from directory, or to new file if checked.

Local file directory

Create new file

Boot configuration Confirm

Upload Configuration File

(h) Most changes are stored in an XML configuration file in the device's Flash file system. Only a few are stored differently, and the IP address is one of those. Normally, clicking Update on any configuration page only stores that configuration information to a temporary RAM copy of the configuration file. To make your changes other than IP address permanent, you must click Save on the Config File page (System :: Setup :: Config File).



3. Minimum BB2-7010 Gateway Setup

The BB2-7010 requires only minimal configuration to be useful in its simplest form. First, you must assign a device instance to the BB2-7010, and you do this via the BACnet IP Port page. You may leave all other settings at their default. You could leave the device instance at its default as well. The only real requirement is that you do not duplicate device instances.

This page displays BACnet IP port settings.

[Refresh](#)

BACnet IP Settings: [Local Network Settings](#)

Device Instance [Save](#)

Port (default 0xBAC0 = 47808)

Device Description

Device Location

APDU Timeout APDU Retries

APDU Segment Timeout Database Revision

Object Count Limits	Input Objects	Output Objects	Value Objects
Analog	<input type="text" value="150"/> [150]	<input type="text" value="10"/> [10]	<input type="text" value="10"/> [10]
Binary	<input type="text" value="30"/> [30]	<input type="text" value="10"/> [10]	<input type="text" value="10"/> [10]
Multi-State	<input type="text" value="30"/> [30]	<input type="text" value="10"/> [10]	<input type="text" value="10"/> [10]

Allow fault self-reset without Ack. Enable BBMD

The number of each type of available object is indicated here. Initially, there will be only 10 AI's and 1 each of the other object types. There is a pool of objects that may be shared among the different object types. The number of objects available is displayed at the "System Capacities" link on the home page of

the device. The number will range from 300 to 1000 depending on model.

The number displayed next to the input window is the object count that has been requested and will take effect upon the next restart. To request a different number, enter that number and click Save. Restart (or power cycle) the device to make the new object allocations take effect.

The check box for "allow fault self-reset without ack" means object reliability code and fault status will return to normal automatically after recovery from a communication fault such as "no response" (reply timed out). If this box is not checked, a BACnet client must read the reliability code to acknowledge the problem before the status will be reset. If the box is checked, fault indications will simply go away when the fault goes away.

The check box for "enable BBMD" is used to enable the BBMD feature of the device. When enabled, additional configuration on the BBMD tab should also be set up.



4. Using the BB2-7010 as a BACnet Server

The BB2-7010 contains a set of BACnet objects whose only purpose is to store copies of data obtained from other devices. This copy of data may then be queried by different devices, or written to different devices by the BB2-7010 client functions.

The collection of objects includes Analog, Binary, and Multi-State types of objects, and includes Input, (commandable) Output, and (writeable) Value types of each of those objects. The BB2-7010 also contains a Device object which is shared with router functions. All of the remaining objects noted here are not used by routing functions.

Data may be placed in the local objects by other devices writing to the BB2-7010, or by the BB2-7010 querying other devices. When the BB2-7010 is configured to query other devices, these operations are defined by "read maps" and "write maps" associated with the respective client function (e.g. BACnet client, Modbus TCP client, SNMP client).

The following pages illustrate the Analog Input object pages and the Binary Output object pages. The remaining object pages found in the BB2-7010 are virtually identical, and are not replicated here.

Each object page initially comes up as a table of object data. Click on the object number in the left-hand column to expand the view of that object and access the windows that let you locally force values, assign units or names, etc.

This page displays data as presently found in the local objects maintained by this device.

Analog Input Objects Showing objects from

Object	Object Name	Out of Service	Present Value	Reliability	Status	Units
1	Volts	N	121.298	0	0,0,0,0	no_units
2	Amps	N	2.19448	0	0,0,0,0	no_units
3	Hertz	N	60.0112	0	0,0,0,0	no_units
4	Watts	N	263.053	0	0,0,0,0	no_units
5	Temperature	N	76.7660	0	0,0,0,0	no_units
6	Humidity	N	80.8409	0	0,0,0,0	no_units
7	Rack Temp	N	98.8300	0	0,0,0,0	no_units
8	Analog Input 8	N	0.00000	0	0,0,0,0	no_units
9	Analog Input 9	N	0.00000	0	0,0,0,0	no_units
10	Analog Input 10	N	0.00000	0	0,0,0,0	no_units
11	Analog Input 11	N	0.00000	0	0,0,0,0	no_units
12	Analog Input 12	N	0.00000	0	0,0,0,0	no_units
13	Analog Input 13	N	0.00000	0	0,0,0,0	no_units
14	Analog Input 14	N	0.00000	0	0,0,0,0	no_units
15	Analog Input 15	N	0.00000	0	0,0,0,0	no_units

The object name, units, value, and status are shown for a list of objects starting with the number entered at the top of the page. Click Prev/Next to scroll through the list. Click on the object number in the first column to change name, units, COV, and out-of-service state.

The source of data for an Analog Input object will be reading the remote Modbus register via the map indicated by the Device Link. The Modbus device will be polled at the rate specified by the Read Map.

Out of Service means polling of the Modbus register will stop. While out of service, the present value may be written by the BACnet client. Data may be forced via this web page at any time, but will be overwritten by the next Modbus poll unless the object is out of service.

Reliability codes may be any of the following (7010-01):

- 64: Modbus client, no response
- 65: Modbus client, crc error
- 66: Modbus exception, illegal function code
- 67: Modbus exception, illegal data address
- 68: Modbus exception, illegal data value
- 69-79: Modbus exception, code+65, rarely used
- 80: Local device, configuration property fault
- 81: Faulty Modbus packet
- 82: BACnet IP client, device timeout
- 83: BACnet IP client, error returned by server

Reliability codes may be any of the following (7010-02):

- 80: Local device, configuration property fault
- 81: Faulty packet
- 82: BACnet IP client, device timeout
- 83: BACnet IP client, error returned by server
- 84: SNMP client, no response from agent
- 85: SNMP client, unable to parse data
- 86: SNMP client, reply does not match request

Status flags A,B,C,D indicate the following, 0 meaning not true, 1 meaning true:

- A = in alarm
- B = fault
- C = overridden
- D = out of service

Device link will indicate BAC or TCP, followed by R for read or W for write, and a number which is the rule number in the table of read or write rules for mapping external devices or objects to this BACnet object. The designation R means read from external device, and W means write to external device.

Click on the AI map number to get to the expanded view of the AI object as illustrated below.

Babel Buster 2
BACNET-MODBUS
NETWORK GATEWAY
MODEL BB2-7010-01

CONTROL SOLUTIONS, INC.
MINNESOTA

Data Objects | Modbus | BACnet | System Setup

Analog | Binary | Multi-State

Input Objects | Output Objects | Value Objects

This page displays data as presently found in the local registers maintained by this device.

Analog Input #

Name: Volts Reliability: 0 Status: 0,0,0,0 Device Link: [RTU R1](#) Out of Service:

Object name: Force Present Value:

COV increment: Units:

The object name, units, value, and status are shown for the object number entered at the top of the page. Click Prev/Next to scroll through the list. Click Refresh to update the page, or Update to accept changes.

The object name may be changed here. BACnet units may be selected. Initial COV increment may be entered. When any of these are changed, be sure to save the updated configuration by clicking Save on the Config File page under System Setup.

The object may be set Out of Service by checking that box and clicking Update. The present value may be changed by entering a value, checking Force, and clicking Update.

The source of data for an Analog Input object will be reading the remote Modbus register via the map indicated by the Device Link. The Modbus device will be polled at the rate specified by the Read Map.

Out of Service means polling of the Modbus register will stop. While out of service, the present value may be written by the BACnet client. Data may be forced via this web page at any time, but will be overwritten by the next Modbus poll unless the object is out of service.

The Binary Output Object page is illustrated below.

Object	Object Name	Out of Service	Present Value	Reliability	Status	Text
<u>1</u>	Relay 1 Out	N	Active	0	0,0,0,0	Contact Closed
<u>2</u>	Binary Output 2	N	Inactive	0	0,0,0,0	
<u>3</u>	Binary Output 3	N	Inactive	0	0,0,0,0	
<u>4</u>	Binary Output 4	N	Inactive	0	0,0,0,0	
<u>5</u>	Binary Output 5	N	Inactive	0	0,0,0,0	
<u>6</u>	Binary Output 6	N	Inactive	0	0,0,0,0	
<u>7</u>	Binary Output 7	N	Inactive	0	0,0,0,0	
<u>8</u>	Binary Output 8	N	Inactive	0	0,0,0,0	
<u>9</u>	Binary Output 9	N	Inactive	0	0,0,0,0	
<u>10</u>	Binary Output 10	N	Inactive	0	0,0,0,0	

The object name, value, and status are shown for a list of objects starting with the number entered at the top of the page. Click Prev/Next to scroll through the list. Click on the object number in the first column to change name or out-of-service state.

The destination of data for a Binary Output object will be writing the remote Modbus register via the map indicated by the Device Link. The Modbus device will be updated upon change of source data and/or periodically as defined by the Write Map.

The Binary Output object is commandable, meaning the BACnet client must write both a value and a priority level for that value. The highest level value will be the one written to the Modbus register. If all values are relinquished, the relinquish default value will be written to the Modbus register.

Out of service means the Modbus register will not be written. Values written by the BACnet client will be retained, but only applied when this object is placed back in service. At that time, the highest priority value will be written to the Modbus register.

Click on the object number in the left-hand column to get to the expanded view of the Binary Output object:

Babel Buster 2
BACNET-MODBUS
NETWORK GATEWAY
MODEL BB2-7010-01

CONTROL SOLUTIONS, INC.
MINNESOTA

Data Objects | Modbus | BACnet | System Setup

Analog | Binary | Multi-State

Input Objects | Output Objects | Value Objects

This page displays data as presently found in the local objects maintained by this device.

Binary Output #

Name: Relay 1 Out Reliability: 0 Status: 0,0,0,0 Device Link: [TCP W1](#) Out of Service:

Object name: Force Present Value:

Active Text: Inctive Text:

Relinquish Default:

Quick Help

The object name, units, value, and status are shown for the object number entered at the top of the page. Click Refresh to update the page, or Update to accept changes.

The object name may be changed here. State text may be entered. When any of these are changed, configuration by clicking Save on the Config File page under System Setup.

The destination of data for a Binary Output object will be writing the remote Modbus register via the map indicated by the Device Link. The Modbus device will be updated upon change of source data and/or periodically as defined by the Write Map.

The Binary Output object is commandable, meaning the BACnet client must write both a value and a priority level for that value. The highest level value will be the one written to the Modbus register. If all values are relinquished, the relinquish default value will be written to the Modbus register.

The object name, units, value, and status are shown for the object number entered at the top of the page. Click Prev/Next to scroll through the list. Click Refresh to update the page, or Update to accept changes.

The object name may be changed here. State text may be entered. When any of these are changed, be sure to save the updated configuration by clicking Save on the Config File page under System Setup.

The destination of data for a Binary Output object will be writing the remote Modbus register via the map indicated by the Device Link. The Modbus device will be updated upon change of source data and/or periodically as defined by the Write Map.

The Binary Output object is commandable, meaning the BACnet client must write both a value and a priority level for that value. The highest level value will be the one written to the Modbus register. If all values are relinquished, the relinquish default value will be written to the Modbus register.

To set an output object manually from this page, check the Force box, enter a value in the Present Value window, and select a priority level to assign to your forced value. Then click Update. To return a given priority level to NULL, simply type the word NULL in the Present Value window, check Force, and click Update.

Out of service means the Modbus register will not be written. Values written by the BACnet client will be

retained, but only applied when this object is placed back in service. At that time, the highest priority value will be written to the Modbus register.



5. Configuring BB2-7010 as a Modbus RTU Master

The BB2-7010 can be a Modbus RTU master or slave. As a master you can read Modbus data from, or write Modbus data to, other Modbus slaves. The BB2-7010 will periodically poll the other Modbus devices according to register maps you set up. To read from a remote Modbus device, configure a Read Map. To write to a remote Modbus device, configure Write Map.

Data read from a remote device is stored in a local register when received. Data written to a remote device is taken from a local register when sent. The local registers are the same collection of registers that are accessible to other masters when operating as slave, and accessible to other Modbus TCP devices as a collection of holding registers.

5.1 Modbus RTU Device Configuration

Modbus device configuration for RTU really consists of port configuration, and includes setting the slave address if the BB2-7010 is functioning as Modbus slave.

This page displays configuration parameters for the Modbus RTU serial port.

Baud Rate: 19200 Parity: None, 1 Stop Bit Update

I am the Master I am a Slave

Parameters for RTU Master:

Default Poll Rate: 5.000 Seconds

Timeout: 1.000 Seconds

Use FC 5/6 instead of 15/16 for unit numbers (slave addresses) starting at 0

Parameters for RTU Slave:

My Address or Unit #: 0

Double registers are swapped

Select baud rate and parity from the drop down list. Click either Master or Slave buttons to select type of operation. Enter timing parameters or address as applicable. Click update to register your changes.

IMPORTANT: Set timeout to something long enough for the device. If too short, the gateway will not wait long enough for a response from the Modbus slave device, and the result will be a lot of "no response" errors from the device even though the device is perfectly functional.

If your slave/server device only supports function codes 5 and 6 for writing, check the Use FC 5/6 box. The default function codes are 15 and 16, which are most widely used. If you check the box, you should also enter a "starting at" unit # or slave address. This allows supporting both types of devices at the same time provided you assign slave addresses in two non-overlapping groups. (These settings do not apply if the BB2-7010 is the slave.)

The double register swap on this page only applies when the local device (the gateway you are configuring here) is functioning as a Modbus RTU slave.

The term "swapped" only applies to double or float formats. Modbus registers are, by definition, 16 bits of data per register. Access to 32-bit data, either 32-bit integer ("double"), or IEEE 754 floating point ("float"), is supported by the use of two consecutive registers. Modbus protocol is inherently "big endian", therefore, Modbus by the Module defaults to having the high order register first for double and float. If the low order register comes first on the device being accessed, check the "swapped" box.

If you have "swapped" turned around, you will quickly recognize it. If floating point data is reversed, a 1.0 becomes 2.2779508e-41, which simply rounds to zero. The pattern is not as predictable as the 1.0 example would suggest. A floating point 1.1 becomes negative 107609184. If 32-bit integer data is reversed, 1 becomes 65536.

5.2 Modbus RTU Master Read Maps

Read remote registers into local registers. This page creates a map entry that reads data from one or more remote Modbus RTU serial devices for processing here. Click on map number to see more detail and insert/delete rules.

Showing 1 to 5 of 5 Update < Prev Next >

Map #	Remote Type	Remote Register Format	Remote Register #	Remote Unit #	Scale	Local Object #	Name
1	Holding Register	Float	1019	2	0.00000	AI1	Volts
2	Holding Register	Float	1163	2	0.00000	AI2	Amps
3	Holding Register	Float	1033	2	0.00000	AI3	Hertz
4	Holding Register	Float	1011	2	0.00000	AI4	Watts
5	None	Integer	0	0	0.00000	0	—

Rule number simply tells you where you're at on the list of register maps. Click "next" and "prev" to scroll through the list. To advance directly to a specific map, enter the desired number in the "Showing" box, then click Update.

Rules entered on this page only read data from remote devices. Go to the RTU Write Map to write data to those devices. The full parameter set is different for read versus write.

An abbreviated version of a list of rules is shown on this page. Any of the parameters shown may be changed here and registered by clicking the Update button. To view and/or modify the complete set of parameters, click on the map number in the left most column.

For each remote register to be read, enter the register type, format, number, and remote unit (slave address).

When the remote register is read, the data will be multiplied by the scale factor and written to the local register number given. The name is optional and used only for display purposes.

Selecting "none" for remote type effectively deletes the rule even though it will still appear in the list until deleted. Unused rules at the end of the list will always show none as the type.

Local register numbers are 1-999 for integer values, and 1001-1999 accessed as register pairs for floating point. If you try to enter an even number above 1001, you will get an error message. All floating point register pairs start on odd boundaries. All local registers are accessed via Modbus as holding registers.

Click on the map number in the left column of the tabular read map page (above) to get the expanded view of one read map at a time (below).

Babel Buster 2
BACNET-MODBUS
NETWORK GATEWAY
MODEL BB2-7010-01

CONTROL SOLUTIONS, INC.
MINNESOTA

Data Objects **Modbus** BACnet System Setup

Modbus RTU Data **Modbus RTU Setup** Modbus TCP Data Modbus TCP Setup

Local Device **RTU Read Map** RTU Write Map

This page creates a map entry that reads data from a remote Modbus RTU serial device for processing here.

Map #

Read as from register # at Unit # with doubles swapped

Apply bit mask if applicable: then apply scale: and offset:

Save in local object # named Repeat this process every seconds.

Apply this default value: after read failure(s).

COV increment: Units:

RTU Read Maps Enabled:

Rule number simply tells you where you're at on the list of register maps. Click "next" and "prev" to scroll through the list. To advance directly to a specific map, enter the desired number in the "Map #" box, then click Update.

For each remote register to be read, enter the register type, format, number, and remote unit (slave address).

When the remote register is read, data may be manipulated before being written to the local register. If a bit mask is entered (in hexadecimal), and the remote register type is signed or unsigned (16-bit data), the mask will be bit-wise logical AND-ed with the data, and the retained bits will be right justified in the result. The result will then be multiplied by the scale factor. The offset is then added and this final result is written to the local register number given. The name is optional and used only for display purposes.

The periodic poll time determines how often the remote register will be read. This number, if nonzero, will override the default poll time given in the Devices page for the remote device being read.

The default value will be stored into the local register after the given number of read failures if the fail count is non-zero. Setting the count to zero will disable the default, and the object will retain the most recent value obtained.

Delete will remove the rule number shown in the "Map #" box. Insert will insert a new rule before the rule number shown, and is used for placing rules between existing rules. It is not necessary to use Insert to add rules to the bottom of the list or to define any rule presently having zero for a source object or "none" for remote type.

Selecting "none" for remote type effectively deletes the rule even though it will still appear in the list until deleted. Unused rules at the end of the list will always show none as the type. If you wish to prevent these from being displayed, reduce the number of rules enabled.

The number of rules enabled simply limits the scope of rule review so that you do not have to review a lot of unused rules. If the displayed rules are used up and you need more, increase the enabled number.

5.3 Modbus RTU Master Write Maps

Write local registers out to remote registers. This page creates a map entry that writes data to one or more remote Modbus RTU serial devices from data contained here. Click on map number to see more detail and insert/delete rules.

Showing 1 to 2 of 2

Map #	Local Object #	Scale	Remote Type	Remote Register Format	Remote Register #	Remote Unit #	Name
1	AV1	0.00000	Holding Register	Integer	19	7	Analog Value 1
2	0	0.00000	None	Integer	0	0	—

Rule number simply tells you where you're at on the list of register maps. Click "next" and "prev" to scroll through the list. To advance directly to a specific map, enter the desired number in the "Showing" box, then click Update.

Rules entered on this page only write data to remote devices. Go to the Client Read Map to read data from those devices. The full parameter set is different for read versus write.

An abbreviated version of a list of rules is shown on this page. Any of the parameters shown may be changed here and registered by clicking the Update button. To view and/or modify the complete set of parameters, click on the map number in the left most column.

Data from the local register given will be multiplied by the scale factor before being written. For each remote register to be written, enter the register type, format, number, and remote unit (slave address).

Selecting "none" for remote type effectively deletes the rule even though it will still appear in the list until deleted. Unused rules at the end of the list will always show none as the type.

Local register numbers are 1-999 for integer values, and 1001-1999 accessed as register pairs for floating point. If you try to enter an even number above 1001, you will get an error message. All floating point register pairs start on odd boundaries. All local registers are accessed via Modbus as holding registers.

Click on the map number in the left column of the tabular write map page (above) to get the expanded view of one write map at a time (below).

Babel Buster 2
BACNET-MODBUS
NETWORK GATEWAY
MODEL BB2-7010-01

CONTROL SOLUTIONS, INC.
MINNESOTA

Data Objects | **Modbus** | BACnet | System Setup

Modbus RTU Data | **Modbus RTU Setup** | Modbus TCP Data | Modbus TCP Setup

Local Device | **RTU Read Map** | RTU Write Map

This page creates a map entry that writes data to a remote Modbus RTU serial device from data contained here.

Map #

Read local object # named

Apply default value of at power-up and/or when seconds have elapsed with no host update.

Write remote register any time local object has changed by or when seconds have elapsed with no change.

Otherwise write remote register unconditionally. In any event, when writing remote register, apply local object data as follows:

Apply scale: and offset: Then if applicable, apply bit mask: and bit fill:

Write as to register # at Unit # with doubles swapped

Repeat this process at least no more than every seconds.

Relinquish Default: COV increment: Units:

Client Write Maps Enabled:

Rule number simply tells you where you're at on the list of register maps. Click "next" and "prev" to scroll through the list. To advance directly to a specific map, enter the desired number in the "Map #" box, then click Update.

The local register data may be written periodically, or when it changes, or both. To send upon change (send on delta), check the first box and enter the amount by which the local register must change before being written to the remote device. To guarantee that the remote register will be written at least

occasionally even if the data does not change, check the second box and enter some amount of time. This time period will be referred to as the "maximum quiet time".

Data from the local register may be manipulated before being written to the remote register. The local data is first multiplied by the scale factor. The offset is then added to it. If a bit mask is entered, and the remote register type is signed or unsigned (16-bit data), the mask will be bit-wise logical AND-ed with the data. The mask is right justified, then AND-ed with the data. The result is then left shifted back to the original position of the mask. In other words, the least significant bits of the original data will be stuffed at the position marked by the mask.

After the scaling and masking, the bit fill will be logically OR-ed into the result, but only if the mask was nonzero and was used. Both mask and fill are entered in hexadecimal.

Multiple local registers may be packed into a single remote register. To accomplish this, define two or more rules in sequence with the same remote destination. If the destination is the same, data types are 16-bit (integer or unsigned), bit masks are nonzero, and the rules are sequential, the results of all qualifying rules will be OR-ed together before being sent to the remote destination.

For the remote register to be written, enter the register type, format, number, and remote unit (slave address).

The repeat time may determine how often the remote register will be written. If send on delta and maximum quiet time are not checked above, clicking the "at least" button will establish a periodic update time. If send on delta is used and you wish to limit the network traffic in the event changes are frequent, click the "no more than" button and enter the minimum time that should elapse before another write to the remote device.

Delete will remove the rule number shown in the "Map #" box. Insert will insert a new rule before the rule number shown, and is used for placing rules between existing rules. It is not necessary to use Insert to add rules to the bottom of the list or to define any rule presently having zero for a source register or "none" for remote type.

Selecting "none" for remote type effectively deletes the rule even though it will still appear in the list until deleted. Unused rules at the end of the list will always show none as the type. If you wish to prevent these from being displayed, reduce the number of rules enabled.

The number of rules enabled simply limits the scope of rule review so that you do not have to review a lot of unused rules. If the displayed rules are used up and you need more, increase the enabled number.

5.4 Modbus RTU Master Data Displayed Per Slave

Babel Buster 2
BACNET-MODBUS
NETWORK GATEWAY
MODEL BB2-7010-01

CONTROL SOLUTIONS, INC.
MINNESOTA

Data Objects | **Modbus** | BACnet | System Setup

Modbus RTU Data | Modbus RTU Setup | Modbus TCP Data | Modbus TCP Setup

RTU Registers | Error Codes

This page displays data to and from registers in devices accessed via the Modbus RTU serial port.

RTU Unit # 2 Showing 1 to 4 of 4 Update < Prev Next >

Dir.	Reg. Type	Remote Reg. #	Register Name	Local Object #	Hex	Update	Register Data	Time since Last update
From	Holding Reg	01019	Volts	AI 1	<input type="checkbox"/>	<input type="checkbox"/>	121.484	3.180
From	Holding Reg	01163	Amps	AI 2	<input type="checkbox"/>	<input type="checkbox"/>	2.21056	3.100
From	Holding Reg	01033	Hertz	AI 3	<input type="checkbox"/>	<input type="checkbox"/>	60.0112	3.070
From	Holding Reg	01011	Watts	AI 4	<input type="checkbox"/>	<input type="checkbox"/>	265.243	3.090

RTU Unit # 2 + Unit - Unit

The values of Modbus registers that have been read from remote RTU serial devices is displayed here. One remote unit at a time is displayed. To display a different unit, change the RTU Unit #.

Simply click the Update button to view the most recent data. Enter a new value and check the Update box if the value should be changed when you click the Update button. Check the Hex box if you wish to view or enter values in hexadecimal (not recommended for floating point).

Click Update to view the most recent data values. Click "Prev" or "Next" to scroll through the list of registers. You may also enter a number in the "Showing" box to jump directly to a given register when Update is clicked.

5.5 Modbus RTU Errors

Babel Buster 2
BACNET-MODBUS
NETWORK GATEWAY
MODEL BB2-7010-01

CONTROL SOLUTIONS, INC.
MINNESOTA

Data Objects | **Modbus** | BACnet | System Setup

Modbus RTU Data | **Modbus RTU Setup** | Modbus TCP Data | Modbus TCP Setup

RTU Registers | **Error Codes**

This page displays error codes encountered in processing reads and writes via the Modbus RTU serial port.

Showing devices from

Unit #	Reset -->	Read Error	Offending Read Map #	Reset -->	Write Error	Offending Write Map #	Reset -->	Total Messages	No Responses	CRC Errors	Exceptions
1	<input type="checkbox"/>	0/0	0	<input type="checkbox"/>	0/0	0	<input type="checkbox"/>	0	0	0	0
2	<input type="checkbox"/>	0/0	0	<input type="checkbox"/>	0/0	0	<input type="checkbox"/>	3744	0	0	0
3	<input type="checkbox"/>	0/0	0	<input type="checkbox"/>	0/0	0	<input type="checkbox"/>	0	0	0	0
4	<input type="checkbox"/>	0/0	0	<input type="checkbox"/>	0/0	0	<input type="checkbox"/>	0	0	0	0
5	<input type="checkbox"/>	0/0	0	<input type="checkbox"/>	0/0	0	<input type="checkbox"/>	0	0	0	0
6	<input type="checkbox"/>	0/0	0	<input type="checkbox"/>	0/0	0	<input type="checkbox"/>	0	0	0	0
7	<input type="checkbox"/>	0/0	0	<input type="checkbox"/>	5/0	1	<input type="checkbox"/>	32	32	0	0
8	<input type="checkbox"/>	0/0	0	<input type="checkbox"/>	0/0	0	<input type="checkbox"/>	0	0	0	0

The first occurrence of read and write errors are shown along with the map number that was being processed when the error occurred. Check the reset box and click update to clear it and possibly show the next error if there are more than one active error conditions.

A total count of all errors is also shown. This total is the sum of errors for all maps for this device. Check the reset box and click update to reset the counts. Click Update to view the most recent data values.

Error code indications of A/B indicate the following errors with the first number:

- 1 = Transaction ID out of sync
- 2 = Exception code returned by remote device
- 3 = Function code mismatch (bad packet)
- 4 = Insufficient data (bad packet)
- 5 = No response from remote device, timed out
- 6 = CRC error in received packet

When A is code 2 indicating an exception code was returned, B indicates the exception as follows:

- 1 = Illegal function code
- 2 = Illegal data address (the requested register does not exist in the device)
- 3 = Illegal data value



6. Configuring BB2-7010 as a Modbus TCP Client

The BB2-7010 can be a Modbus client or server. As a client (master) you can read Modbus data from, or write Modbus data to, other Modbus servers (slaves). The BB2-7010 will periodically poll the other Modbus devices according to register maps you set up. The Modbus server (slave) devices that you will read/write are defined on the Devices page. To read from a remote Modbus device, configure a Read Map. To write to a remote Modbus device, configure Write Map.

Data read from a remote device is stored in a local data object when received. Data written to a remote device is taken from a local data object when sent. The local data objects are the same collection of objects that are accessible to other clients via the server map, and accessible to other BACnet devices via MS/TP or BACnet IP.

6.1 Modbus TCP Device Configuration

This page sets up the network address and optional device parameters for a remote Modbus/TCP device that will be linked to for remote input and/or output (via the client read and client write maps). The local device acts as a Modbus master to the remote devices listed below.

Device #

IP Address Port Local Name:

Unit (optional) Use FC 5/6 instead of 15/16

Swap Double Registers Connection Status

Default Poll Period Seconds

The Modbus Devices page is illustrated above. Device number simply shows you where you are on the device list. Click "next" and "prev" to scroll through the list.

Remote Modbus/TCP devices to be accessed by this device are specified here. Enter the IP address of the remote device, a name to reference in other pages, a unit number, poll rate, and check "swapped" if appropriate. Then click "update".

If your slave/server device only supports function codes 5 and 6 for writing, check the Use FC 5/6 box. The default function codes are 15 and 16, which are most widely used.

The term "swapped" only applies to double or float formats. Modbus registers are, by definition, 16 bits of data per register. Access to 32-bit data, either 32-bit integer ("double"), or IEEE 754 floating point ("float"), is supported by the use of two consecutive registers. Modbus protocol is inherently "big endian", therefore, Modbus by the Module defaults to having the high order register first for double and float. If the low order register comes first on the device being accessed, check the "swapped" box.

If you have "swapped" turned around, you will quickly recognize it. If floating point data is reversed, a 1.0 becomes 2.2779508e-41, which simply rounds to zero. The pattern is not as predictable as the 1.0 example would suggest. A floating point 1.1 becomes negative 107609184. If 32-bit integer data is reversed, 1 becomes 65536.

Connection status will show a non-zero error code if there is a socket error. Possible errors include:

- 5 = Connection failed, unable to bind (usually means remote device not connected or not reachable)
- 81 = Connection in progress (means unsuccessful connect attempt, still trying)
- 95 = Network is unreachable
- 97 = Connection aborted
- 98 = Connection reset by peer
- 103 = Connection timed out
- 104 = Connection refused
- 107 = Host is unreachable

6.2 Modbus TCP Client Read Maps

Read remote registers into local objects. This page creates a map entry that reads data from one or more remote Modbus/TCP servers for processing here. Click on map number to see more detail and insert/delete rules.

Showing 1 to 2 of 2 Update < Prev Next >

Map #	Remote Type	Remote Register Format	Remote Register #	Remote Device	Scale	Local Object #	Name
1	Holding Register	Float	1001	Rack Monitor	0.00000	AI 7	Rack Temp
2	None	Integer	0	None	0.00000	0	—

Rule number simply tells you where you're at on the list of register maps. Click "next" and "prev" to scroll through the list. To advance directly to a specific map, enter the desired number in the "Showing" box, then click Update.

Rules entered on this page only read data from remote devices. Go to the Client Write Map to write data to those devices. The full parameter set is different for read versus write.

An abbreviated version of a list of rules is shown on this page. Any of the parameters shown may be changed here and registered by clicking the Update button. To view and/or modify the complete set of parameters, click on the map number in the left most column.

For each remote register to be read, enter the register type, format, number, and location (device). The names in the device list are defined in the Devices page.

When the remote register is read, the data will be multiplied by the scale factor and written to the local object number given. The name is optional and used only for display purposes.

Selecting "none" for remote type effectively deletes the rule even though it will still appear in the list until deleted. Unused rules at the end of the list will always show none as the type.

Local Object is internally a coded number consisting of BACnet object type multiplied by 1000, then added to the object number starting from #1. These are translated into abbreviations that are easy to interpret on the web page as follows:

AI n = Analog Input #n
 AO n = Analog Output #n
 AV n = Analog Value #n
 BI n = Binary Input #n
 BO n = Binary Output #n
 BV n = Binary Value #n
 MI n = Multi-state Input #n
 MO n = Multi-state Output #n
 MV n = Multi-state Value #n

Object numbers start at #1. The maximum available number varies by object type, and these limits may be found on the System Capacities link from the home/index page (click graphic at top).

Babel Buster 2
 BACNET-MODBUS
 NETWORK GATEWAY
 MODEL BB2-7010-01

CONTROL SOLUTIONS, INC.
 MINNESOTA

Data Objects | **Modbus** | BACnet | System Setup

Modbus RTU Data | Modbus RTU Setup | Modbus TCP Data | Modbus TCP Setup

Devices | Client Read Map | Client Write Map | Server Map

This page creates a map entry that reads data from a remote Modbus/TCP server for processing here.

Map #

Read as from register # at

Apply bit mask if applicable: then apply scale: and offset:

Save in local object # named Repeat this process every seconds.

Apply this default value: after read failure(s).

Initial COV increment: Units:

Client Read Maps Enabled:

Rule number simply tells you where you're at on the list of register maps. Click "next" and "prev" to scroll through the list. To advance directly to a specific map, enter the desired number in the "Map #" box, then click Update.

For each remote register to be read, enter the register type, format, number, and location (device). The names in the device list are defined in the Devices page.

When the remote register is read, data may be manipulated before being written to the local object. If a bit mask is entered (in hexadecimal), and the remote register type is signed or unsigned (16-bit data), the mask will be bit-wise logical AND-ed with the data, and the retained bits will be right justified in the result. The result will then be multiplied by the scale factor. The offset is then added and this final result is written to the local object number given. The name is optional and used only for display purposes.

The periodic poll time determines how often the remote register will be read. This number, if nonzero, will override the default poll time given in the Devices page for the remote device being read.

The default value will be stored into the local object after the given number of read failures if the fail count is non-zero. Setting the count to zero will disable the default, and the object will retain the most recent value obtained.

Delete will remove the rule number shown in the "Map #" box. Insert will insert a new rule before the rule number shown, and is used for placing rules between existing rules. It is not necessary to use Insert to add rules to the bottom of the list or to define any rule presently having zero for a source object or "none" for remote type.

Selecting "none" for remote type effectively deletes the rule even though it will still appear in the list until deleted. Unused rules at the end of the list will always show none as the type. If you wish to prevent these from being displayed, reduce the number of rules enabled.

Initial COV increment and period will only apply if a BACnet client subscribes to COV notification from the BACnet object assigned to this Modbus map. These properties may be overwritten by the BACnet client(s) at any time. The values shown here are initial values, not necessarily the current values. (Note: COV increment only applies to Analog objects, all changes are reported for Binary or Multistate objects.)

Units default to no_units, but you may select any of the available BACnetEngineeringUnits values. This value will simply be read by the BACnet client when the units property is requested from the object this Modbus register maps to. The units have no bearing on calculations performed. You must select appropriate scale and offset values to make any required translation between Modbus units and BACnet units. Units are only valid for Analog objects.

The number of rules enabled simply limits the scope of rule review so that you do not have to review a lot of unused rules. If the displayed rules are used up and you need more, increase the enabled number.

6.3 Modbus TCP Client Write Maps

Map #	Local Object #	Scale	Remote Type	Remote Register Format	Remote Register #	Remote Device	Name
1	BO 1	0.00000	Holding Register	Integer	15	Rack Monitor	Relay 1 Out
2	0	0.00000	None	Integer	0	None	—

Rule number simply tells you where you're at on the list of register maps. Click "next" and "prev" to scroll through the list. To advance directly to a specific map, enter the desired number in the "Showing" box, then click Update.

Rules entered on this page only write data to remote devices. Go to the Client Read Map to read data from those devices. The full parameter set is different for read versus write.

An abbreviated version of a list of rules is shown on this page. Any of the parameters shown may be changed here and registered by clicking the Update button. To view and/or modify the complete set of parameters, click on the map number in the left most column.

Data from the local object given will be multiplied by the scale factor before being written. For each remote register to be written, enter the register type, format, number, and location (device). The names in the device list are defined in the Devices page. The name is optional and used only for display purposes.

Selecting "none" for remote type effectively deletes the rule even though it will still appear in the list until deleted. Unused rules at the end of the list will always show none as the type.

Local Object is internally a coded number consisting of BACnet object type multiplied by 1000, then added to the object number starting from #1. These are translated into abbreviations that are easy to interpret on the web page as follows:

AI n = Analog Input #n
 AO n = Analog Output #n
 AV n = Analog Value #n
 BI n = Binary Input #n
 BO n = Binary Output #n
 BV n = Binary Value #n
 MI n = Multi-state Input #n
 MO n = Multi-state Output #n
 MV n = Multi-state Value #n

Object numbers start at #1. The maximum available number varies by object type, and these limits may be found on the System Capacities link from the home/index page (click graphic at top).

Babel Buster 2
BACNET-MODBUS
NETWORK GATEWAY
MODEL BB2-7010-01

CONTROL SOLUTIONS, INC.
MINNESOTA

Data Objects | **Modbus** | BACnet | System Setup

Modbus RTU Data | Modbus RTU Setup | Modbus TCP Data | **Modbus TCP Setup**

Devices | Client Read Map | Client Write Map | Server Map

This page creates a map entry that writes data to one or more remote Modbus/TCP servers from data contained here.

Map #

Read local object # named

Apply default value of at power-up and/or when seconds have elapsed with no host update.

Write remote register any time local object has changed by or when seconds have elapsed with no change.

Otherwise write remote register unconditionally. In any event, when writing remote register, apply local object data as follows:

Apply scale: and offset: Then if applicable, apply bit mask: and bit fill:

Write as to register # at

Repeat this process at least no more than every seconds.

Relinquish Default: COV increment: Units:

Client Write Maps Enabled:

Rule number simply tells you where you're at on the list of register maps. Click "next" and "prev" to scroll through the list. To advance directly to a specific map, enter the desired number in the "Map #" box, then click Update.

The local object data may be written periodically, or when it changes, or both. To send upon change (send on delta), check the first box and enter the amount by which the local object must change before being written to the remote device. To guarantee that the remote register will be written at least occasionally even if the data does not change, check the second box and enter some amount of time. This time period will be referred to as the "maximum quiet time".

Data from the local object may be manipulated before being written to the remote register. The local data is first multiplied by the scale factor. The offset is then added to it. If a bit mask is entered, and the remote register type is signed or unsigned (16-bit data), the mask will be bit-wise logical AND-ed with the data. The mask is right justified, then AND-ed with the data. The result is then left shifted back to the original position of the mask. In other words, the least significant bits of the original data will be stuffed at the position marked by the mask.

After the scaling and masking, the bit fill will be logically OR-ed into the result, but only if the mask was nonzero and was used. Both mask and fill are entered in hexadecimal.

Multiple local objects may be packed into a single remote register. To accomplish this, define two or more rules in sequence with the same remote destination. If the destination is the same, data types are 16-bit (integer or unsigned), bit masks are nonzero, and the rules are sequential, the results of all qualifying rules will be OR-ed together before being sent to the remote destination.

For the remote register to be written, enter the register type, format, number, and location (device). The names in the device list are defined in the Devices page.

The repeat time may determine how often the remote register will be written. If send on delta and maximum quiet time are not checked above, clicking the "at least" button will establish a periodic update time. If send on delta is used and you wish to limit the network traffic in the event changes are frequent, click the "no more than" button and enter the minimum time that should elapse before another write to the remote device.

Delete will remove the rule number shown in the "Map #" box. Insert will insert a new rule before the rule number shown, and is used for placing rules between existing rules. It is not necessary to use Insert to add rules to the bottom of the list or to define any rule presently having zero for a source register or "none" for remote type.

Selecting "none" for remote type effectively deletes the rule even though it will still appear in the list until deleted. Unused rules at the end of the list will always show none as the type. If you wish to prevent these from being displayed, reduce the number of rules enabled.

Initial COV increment and period will only apply if a BACnet client subscribes to COV notification from the BACnet object assigned to this Modbus map. These properties may be overwritten by the BACnet client(s) at any time. The values shown here are initial values, not necessarily the current values. (Note: COV increment only applies to Analog objects, all changes are reported for Binary or Multistate objects.)

Units default to no_units, but you may select any of the available BACnetEngineeringUnits values. This value will simply be read by the BACnet client when the units property is requested from the object this Modbus register maps to. The units have no bearing on calculations performed. You must select appropriate scale and offset values to make any required translation between Modbus units and BACnet units. Units are only valid for Analog objects.

Initial Relinquish Default may be set here, but may be overwritten by the BACnet client at any time. This window reflects the initial value, not the current value. (Note: Relinquish Default only applies to commandable Output objects, and does not apply to Input or Value objects.)

The number of rules enabled simply limits the scope of rule review so that you do not have to review a lot of unused rules. If the displayed rules are used up and you need more, increase the enabled number.

6.4 Modbus TCP Errors

This page displays error codes encountered in processing Modbus Client reads and writes via the Modbus TCP connection(s).

Device	Reset -->	Read Error	Offending Read Map #	Reset -->	Write Error	Offending Write Map #	Reset -->	Total Messages	No Responses	Exceptions
1	<input type="checkbox"/>	0/0	0	<input type="checkbox"/>	0/0	0	<input type="checkbox"/>	56952	0	0
2	<input type="checkbox"/>	0/0	0	<input type="checkbox"/>	0/0	0	<input type="checkbox"/>	0	0	0
3	<input type="checkbox"/>	0/0	0	<input type="checkbox"/>	0/0	0	<input type="checkbox"/>	0	0	0
4	<input type="checkbox"/>	0/0	0	<input type="checkbox"/>	0/0	0	<input type="checkbox"/>	0	0	0
5	<input type="checkbox"/>	0/0	0	<input type="checkbox"/>	0/0	0	<input type="checkbox"/>	0	0	0
6	<input type="checkbox"/>	0/0	0	<input type="checkbox"/>	0/0	0	<input type="checkbox"/>	0	0	0
7	<input type="checkbox"/>	0/0	0	<input type="checkbox"/>	0/0	0	<input type="checkbox"/>	0	0	0
8	<input type="checkbox"/>	0/0	0	<input type="checkbox"/>	0/0	0	<input type="checkbox"/>	0	0	0

The first occurrence of read and write errors are shown along with the map number that was being processed when the error occurred. Check the reset box and click update to clear it and possibly show the next error if there are more than one active error conditions.

A total count of all errors is also shown. This total is the sum of errors for all maps for this device. Check the reset box and click update to reset the counts. Click Update to view the most recent data values.

Error code indications of A/B indicate the following errors with the first number:

- 1 = Transaction ID out of sync
- 2 = Exception code returned by remote device
- 3 = Function code mismatch (bad packet)
- 4 = Insufficient data (bad packet)
- 5 = No response from remote device, timed out
- 6 = CRC error in received packet

When A is code 2 indicating an exception code was returned, B indicates the exception as follows:

- 1 = Illegal function code
- 2 = Illegal data address (the requested register does not exist in the device)
- 3 = Illegal data value



7. Using the BB2-7010 as a BACnet Client

The BACnet client is used to query other BACnet devices, obtain their Present Value data, and store a copy of that data in the BB2-7030's own local objects. From there, the data may be accessed by Modbus TCP or SNMP devices, or other BACnet devices when application specific reasons make this approach more preferred than direct routing.

7.1. BACnet Device Configuration

Setting up the BACnet client consists of identifying one or more BACnet devices, then listing the objects that should be queried (whether read or written). The client configuration pages are illustrated below.

This page sets up the device list for remote BACnet IP devices that will be accessed for remote input and/or output (via the client read and client write maps). The local device acts as a BACnet client to the remote servers listed below.

Device #

Device Instance: Local Name:

Default Poll Period: Seconds Default Write Priority:

Reply Timeout: Seconds Timeouts:

Address Binding: Dynamic (Who-Is) Static

Device IP Address:

Device number simply shows you where you are on the device list. Click "next" and "prev" to scroll through the list.

Remote BACnet devices to be accessed by this device are specified here. Enter the Device Instance of the remote device, a name to reference in other pages, a poll rate, default reply timeout, and default write priority. Enter static address if applicable. Then click "update".

The gateway broadcasts a "who-is" looking for this device when a read or write map wants to use this device. When (if) it responds, its IP address or MS/TP mac address is listed here simply as a diagnostic. Timeouts resulting from inability to reach this device are tabulated on this page as well, and may be cleared by clicking the Clear button. To cause the who-is process to be repeated, click Clear Cache.

BACnet IP or MS/TP slave devices that do not support Who-Is/I-Am can still be supported here. When this is the case, enter the slave device's Mac address in the Static Mac window and check the 'No Who-Is' box. If located on a remote network via a router, enter the network number as DNet. This static entry effectively replies to the implied Who-Is.

To use a fixed static address, enter a single number for MS/TP MAC address. or an IP address optionally including port number. An example of IP address with port number would be 192.168.1.99:47808. The 47808 is the port number, and is separated from the IP address by a colon. Note that 47808 is the default 0xBAC0 port number. If no port number is given, the port configured on the BACnet IP Port page will be used (the BB2-7010's own port).

7.2. BACnet Client Read Maps

The client read maps tell the BB2-7010 which objects to read, from which BACnet devices. Click on the map number to view the full details of the read map.

Read remote object data into local objects. This page creates a map entry that reads data from one or more remote BACnet IP servers for processing here. Click on map number to see more detail and insert/delete maps.

Showing 1 to 3 of 3

Map #	Remote Type	Remote Object #	Remote Device	Scale	Local Object #	Name
<u>1</u>	Analog Input	1	BB2-7010-02	0.00000	AI 5	Temperature
<u>2</u>	Analog Input	2	BB2-7010-02	0.00000	AI 6	Humidity
<u>3</u>	None	0	None	0.00000	0	—

Map number simply tells you where you're at on the list of register maps. Click "next" and "prev" to scroll through the list. To advance directly to a specific map, enter the desired number in the "Showing" box, then click Update.

Maps entered on this page only read data from remote devices. Go to the Client Write Map to write data to those devices. The full parameter set is different for read versus write.

An abbreviated version of a list of maps is shown on this page. Any of the parameters shown may be changed here and registered by clicking the Update button. To view and/or modify the complete set of parameters, click on the map number in the left most column.

For each remote object to be read, enter the object instance and type, and location (device). The names in

the device list are defined in the Devices page.

When the remote object is read, data may be manipulated before being written to the local object. The value will be multiplied by the scale factor. The final result is written to the local object number given. The name is optional and used only for display purposes.

Selecting "none" for remote type effectively deletes the map even though it will still appear in the list until deleted. Unused maps at the end of the list will always show none as the type.

Local Object is internally a coded number consisting of BACnet object type multiplied by 1000, then added to the object number starting from #1. These are translated into abbreviations that are easy to interpret on the web page as follows:

AI n = Analog Input #n
 AO n = Analog Output #n
 AV n = Analog Value #n
 BI n = Binary Input #n
 BO n = Binary Output #n
 BV n = Binary Value #n
 MI n = Multi-state Input #n
 MO n = Multi-state Output #n
 MV n = Multi-state Value #n

Object numbers start at #1. The maximum available number varies by object type, and these limits may be found on the System Capacities link from the home/index page (click graphic at top).

Babel Buster 2
 BACNET-MODBUS
 NETWORK GATEWAY
 MODEL BB2-7010-01

CONTROL SOLUTIONS, INC.
 MINNESOTA

Data Objects Modbus **BACnet** System Setup

BACnet IP Client Diagnostics

Devices Client Read Map Client Write Map

This page creates a map entry that reads data from a remote BACnet IP server for processing here.

Map #

Read property instance # of object type

Read from device using index

Then apply scale: and offset:

Save in local object named Repeat this process every seconds.

Apply this default value: after read failure(s).

Client Read Maps Enabled:

Rule number simply tells you where you're at on the list of object maps. Click "next" and "prev" to scroll through the list. To advance directly to a specific map, enter the desired number in the "Map #" box, then click Update.

For each remote object to be read, enter the object instance and type, and location (device). The names in the device list are defined in the Devices page. Use index value of 0 if no index.

When the remote object is read, data may be manipulated before being written to the local object. The value will be multiplied by the scale factor, then the offset is added. The final result is written to the local object number given. The name is optional and used only for display purposes.

The periodic poll time determines how often the remote object will be read. This number, if nonzero, will override the default poll time given in the Devices page for the remote device being read.

The default value will be stored into the local object after the given number of read failures if the fail count is non-zero. Setting the count to zero will disable the default, and the object will retain the most recent value obtained.

Delete will remove the rule number shown in the "Map #" box. Insert will insert a new map before the map number shown, and is used for placing maps between existing maps. It is not necessary to use Insert to add maps to the bottom of the list or to define any map presently having zero for a source object or "none" for remote type.

Selecting "none" for remote type effectively deletes the map even though it will still appear in the list until deleted. Unused maps at the end of the list will always show none as the type. If you wish to prevent these from being displayed, reduce the number of maps enabled.

The number of maps enabled simply limits the scope of map review so that you do not have to review a lot of unused maps. If the displayed maps are used up and you need more, increase the enabled number.

7.3. BACnet Client Write Maps

The client read maps tell the BB2-7010 which objects to write, on which BACnet devices. Click on the map number to view the full details of the write map.



Babel Buster 2
BACNET-MODBUS
NETWORK GATEWAY
MODEL BB2-7010-01

CONTROL SOLUTIONS, INC.
MINNESOTA

Data Objects | Modbus | **BACnet** | System Setup

BACnet IP Client | Diagnostics

Devices | Client Read Map | **Client Write Map**

Write local object data out to remote objects. This page creates a map entry that writes data to one or more remote BACnet IP servers from data contained here. Click on map number to see more detail and insert/delete rules.

Showing 1 to 2 of 2 Update < Prev Next >

Map #	Local Object #	Scale	Remote Type	Remote Object #	Remote Device	Name
1	BO 2	0.00000	Binary Output	3	BB2-7010-02	Relay 2
2	0	0.00000	None	0	None	—

Map number simply tells you where you're at on the list of register maps. Click "next" and "prev" to scroll through the list. To advance directly to a specific map, enter the desired number in the "Showing" box, then click Update.

Maps entered on this page only write data to remote devices. Go to the Client Read Map to read data from those devices. The full parameter set is different for read versus write.

An abbreviated version of a list of maps is shown on this page. Any of the parameters shown may be changed here and registered by clicking the Update button. To view and/or modify the complete set of parameters, click on the map number in the left most column.

Data from the local object given will be multiplied by the scale factor before being written. For each remote object to be written, enter the object instance and type, and location (device). The names in the device list are defined in the Devices page. The name is optional and used only for display purposes.

Selecting "none" for remote type effectively deletes the map even though it will still appear in the list until deleted. Unused maps at the end of the list will always show none as the type.

Local Object is internally a coded number consisting of BACnet object type multiplied by 1000, then added to the object number starting from #1. These are translated into abbreviations that are easy to interpret on the web page as follows:

AI n = Analog Input #n
AO n = Analog Output #n
AV n = Analog Value #n
BI n = Binary Input #n
BO n = Binary Output #n
BV n = Binary Value #n
MI n = Multi-state Input #n
MO n = Multi-state Output #n
MV n = Multi-state Value #n

Object numbers start at #1. The maximum available number varies by object type, and these limits may be found on the System Capacities link from the home/index page (click graphic at top).

Babel Buster 2
BACNET-MODBUS
NETWORK GATEWAY
MODEL BB2-7010-01

CONTROL SOLUTIONS, INC.
MINNESOTA

Data Objects Modbus **BACnet** System Setup

BACnet IP Client Diagnostics

Devices Client Read Map Client Write Map

This page creates a map entry that writes data to one or more remote BACnet IP servers from data contained here.

Map #

Read local object named

Apply default value of at power-up and/or when seconds have elapsed with no host update.

Write remote register any time local object has changed by or when seconds have elapsed with no change.

Otherwise write remote register unconditionally. In any event, when writing remote register, apply local object data as follows:

Apply scale: and offset: Then, using index and priority proceed to

Write property encoded as data type

Write to instance # of object type at device

Repeat this process at least no more than every seconds.

Client Write Maps Enabled:

Rule number simply tells you where you're at on the list of object maps. Click "next" and "prev" to scroll through the list. To advance directly to a specific map, enter the desired number in the "Map #" box, then click Update.

The local object data may be written periodically, or when it changes, or both. To send upon change (send on delta), check the first box and enter the amount by which the local object must change before being written to the remote device. To guarantee that the remote object will be written at least occasionally even if the data does not change, check the second box and enter some amount of time. This time period will be referred to as the "maximum quiet time".

Data from the local object may be manipulated before being written to the remote register. The local data is first multiplied by the scale factor. The offset is then added to it.

For the remote object to be written, enter the object instance and type, index if applicable (leave at 0 if not), and priority to use of the object being written is commandable. The names in the device list are defined in the Devices page.

The repeat time may determine how often the remote object will be written. If send on delta and maximum quiet time are not checked above, clicking the "at least" button will establish a periodic update time. If send on delta is used and you wish to limit the network traffic in the event changes are frequent, click the "no more than" button and enter the minimum time that should elapse before another write to the remote device.

Delete will remove the rule number shown in the "Map #" box. Insert will insert a new map before the

map number shown, and is used for placing maps between existing maps. It is not necessary to use Insert to add maps to the bottom of the list or to define any map presently having zero for a source object or "none" for remote type.

Selecting "none" for remote type effectively deletes the map even though it will still appear in the list until deleted. Unused maps at the end of the list will always show none as the type. If you wish to prevent these from being displayed, reduce the number of maps enabled.

The number of maps enabled simply limits the scope of map review so that you do not have to review a lot of unused maps. If the displayed maps are used up and you need more, increase the enabled number.

7.4. BACnet Errors

If errors are detected in the course of reading or writing other BACnet objects via the client's maps, they will be indicated on the errors pages.

Babel Buster 2
BACNET-MODBUS
NETWORK GATEWAY
MODEL BB2-7010-01

CONTROL SOLUTIONS, INC.
MINNESOTA

Data Objects | Modbus | **BACnet** | System Setup

BACnet IP Client | Diagnostics

Errors: Read Maps | Errors: Write Maps

This page displays errors, if any, reported by the remote server upon attempts to read from that device.

<< Top | Next >

Map #	Remote Type	Remote Object #	Remote Device	Name	Error Class	Error Code
--	---	0	---	---	0	0

Reset Errors

Errors for BACnet IP client read maps are shown on this page. Only those maps with errors to report are listed. Refer to the code and class lists below for interpretation.

Proprietary class 82, code 0, is generated locally indicating a timeout, no response received from remote server. All other codes listed below are returned by the remote server.

0 = ERROR_CLASS_DEVICE
 1 = ERROR_CLASS_OBJECT
 2 = ERROR_CLASS_PROPERTY
 3 = ERROR_CLASS_RESOURCES
 4 = ERROR_CLASS_SECURITY
 5 = ERROR_CLASS_SERVICES

/* valid for all classes */
 0 = ERROR_CODE_OTHER

/* Error Class - Device */

```
2 = ERROR_CODE_CONFIGURATION_IN_PROGRESS
3 = ERROR_CODE_DEVICE_BUSY
25 = ERROR_CODE_OPERATIONAL_PROBLEM
```

```
/* Error Class - Object */
```

```
4 = ERROR_CODE_DYNAMIC_CREATION_NOT_SUPPORTED
17 = ERROR_CODE_NO_OBJECTS_OF_SPECIFIED_TYPE
23 = ERROR_CODE_OBJECT_DELETION_NOT_PERMITTED
24 = ERROR_CODE_OBJECT_IDENTIFIER_ALREADY_EXISTS
27 = ERROR_CODE_READ_ACCESS_DENIED
31 = ERROR_CODE_UNKNOWN_OBJECT
36 = ERROR_CODE_UNSUPPORTED_OBJECT_TYPE
```

```
/* Error Class - Property */
```

```
8 = ERROR_CODE_INCONSISTENT_SELECTION_CRITERION
9 = ERROR_CODE_INVALID_DATA_TYPE
32 = ERROR_CODE_UNKNOWN_PROPERTY
37 = ERROR_CODE_VALUE_OUT_OF_RANGE
40 = ERROR_CODE_WRITE_ACCESS_DENIED
41 = ERROR_CODE_CHARACTER_SET_NOT_SUPPORTED
42 = ERROR_CODE_INVALID_ARRAY_INDEX
44 = ERROR_CODE_NOT_COV_PROPERTY
45 = ERROR_CODE_OPTIONAL_FUNCTIONALITY_NOT_SUPPORTED
47 = ERROR_CODE_DATATYPE_NOT_SUPPORTED
50 = ERROR_CODE_PROPERTY_IS_NOT_AN_ARRAY
```

```
/* Error Class - Resources */
```

```
18 = ERROR_CODE_NO_SPACE_FOR_OBJECT
19 = ERROR_CODE_NO_SPACE_TO_ADD_LIST_ELEMENT
20 = ERROR_CODE_NO_SPACE_TO_WRITE_PROPERTY
```

```
/* Error Class - Security */
```

```
1 = ERROR_CODE_AUTHENTICATION_FAILED
6 = ERROR_CODE_INCOMPATIBLE_SECURITY_LEVELS
12 = ERROR_CODE_INVALID_OPERATOR_NAME
15 = ERROR_CODE_KEY_GENERATION_ERROR
26 = ERROR_CODE_PASSWORD_FAILURE
28 = ERROR_CODE_SECURITY_NOT_SUPPORTED
30 = ERROR_CODE_TIMEOUT
```

```
/* Error Class - Services */
```

```
5 = ERROR_CODE_FILE_ACCESS_DENIED
7 = ERROR_CODE_INCONSISTENT_PARAMETERS
10 = ERROR_CODE_INVALID_FILE_ACCESS_METHOD
11 = ERROR_CODE_ERROR_CODE_INVALID_FILE_START_POSITION
13 = ERROR_CODE_INVALID_PARAMETER_DATA_TYPE
14 = ERROR_CODE_INVALID_TIME_STAMP
16 = ERROR_CODE_MISSING_REQUIRED_PARAMETER
22 = ERROR_CODE_PROPERTY_IS_NOT_A_LIST
29 = ERROR_CODE_SERVICE_REQUEST_DENIED
43 = ERROR_CODE_COV_SUBSCRIPTION_FAILED
46 = ERROR_CODE_INVALID_CONFIGURATION_DATA
48 = ERROR_CODE_DUPLICATE_NAME
49 = ERROR_CODE_DUPLICATE_OBJECT_ID
```



8. Configuring BB2-7010 as a Modbus RTU Slave

The BB2-7010 can be a Modbus RTU master or slave. As slave, the BB2-7010 will respond to another Modbus master and return data requested. The various objects in the BB2-7010 are accessed as holding registers, with register numbers calculated and based on object type and instance.

8.1 Modbus RTU Device Configuration

Modbus device configuration for RTU really consists of port configuration, and includes setting the slave address if the BB2-7010 is functioning as Modbus slave.

This page displays configuration parameters for the Modbus RTU serial port.

Baud Rate: 19200 Parity: None, 1 Stop Bit Update

I am the Master
 Parameters for RTU Master:
 Default Poll Rate: 5.000 Seconds
 Timeout: 1.000 Seconds
 Use FC 5/6 instead of 15/16 for unit numbers (slave addresses) starting at: 0

I am a Slave
 Parameters for RTU Slave:
 My Address or Unit #: 5
 Double registers are swapped

Select baud rate and parity from the drop down list. Click either Master or Slave buttons to select type of operation. Enter timing parameters or address as applicable. Click update to register your changes.

The double register swap on this page only applies when the local device (the gateway you are configuring here) is functioning as a Modbus RTU slave. If the Modbus master expects least significant data to be in the first (lowest numbered) register, then check the "swap" box.

The term "swapped" only applies to double or float formats. Modbus registers are, by definition, 16 bits of data per register. Access to 32-bit data, either 32-bit integer ("double"), or IEEE 754 floating

point ("float"), is supported by the use of two consecutive registers. Modbus protocol is inherently "big endian", therefore, Modbus by the Module defaults to having the high order register first for double and float. If the low order register comes first on the device being accessed, check the "swapped" box.

If you have "swapped" turned around, you will quickly recognize it. If floating point data is reversed, a 1.0 becomes 2.2779508e-41, which simply rounds to zero. The pattern is not as predictable as the 1.0 example would suggest. A floating point 1.1 becomes negative 107609184. If 32-bit integer data is reversed, 1 becomes 65536.

8.2 Modbus RTU Slave Register Mapping

The mappings shown below are used when the BB2-7010 is treated as a Modbus RTU Slave. All objects are accessed as holding registers. Analog registers MUST be read as a register pair, and will return IEEE754 floating point.

Analog Input Object

Must be read/written as Floating Point (IEEE 754) register pair, most significant register first.

ANALOG INPUT	
Object	Modbus Registers
AI #1	1 (read 1,2 as pair)
AI #2	3 (read 3,4 as pair)
AI #3	5 (read 5,6 as pair)
AI #300	599 (read 599,600 as pair)

Analog Output Object

Must be read/written as Floating Point (IEEE 754) register pair, most significant register first.

ANALOG OUTPUT	
Object	Modbus Registers
AO #1	1001 (read 1001,1002 as pair)
AO #2	1003 (read 1003,1004 as pair)
AO #3	1005 (read 1005,1006 as pair)
AO #100	1199 (read 1199,1200 as pair)

Analog Value Object

Must be read/written as Floating Point (IEEE 754) register pair, most significant register first.

ANALOG VALUE	
Object	Modbus Registers
AV #1	2001 (read 2001,2002 as pair)
AV #2	2003 (read 2003,2004 as pair)
AV #3	2005 (read 2005,2006 as pair)
AV #100	2199 (read 2199,2200 as pair)

Binary Input Object

Read/written as a single holding register, any non-zero value written will result in bit set.

BINARY INPUT	
Object	Modbus Registers
BI #1	3001
BI #2	3002
BI #3	3003
BI #300	3300

Binary Output Object

Read/written as a single holding register, any non-zero value written will result in bit

BINARY OUTPUT	
Object	Modbus Registers
BO #1	4001
BO #2	4002

set.

BO #3	4003
BO #100	4100

Binary Value Object

Read/written as a single holding register, any non-zero value written will result in bit set.

BINARY VALUE	
Object	Modbus Registers
BV #1	5001
BV #2	5002
BV #3	5003
BV #100	5100

Multi-state Input Object

Read/written as single holding register, treated as unsigned 16-bit integer.

MULTI-STATE INPUT	
Object	Modbus Registers
MI #1	13001
MI #2	13002
MI #3	13003
MI #300	13300

Multi-state Output Object

Read/written as single holding register, treated as unsigned 16-bit integer.

MULTI-STATE OUTPUT	
Object	Modbus Registers
MO #1	14001
MO #2	14002
MO #3	14003
MO #100	14100

Multi-state Value Object

Read/written as single holding register, treated as unsigned 16-bit integer.

MULTI-STATE VALUE	
Object	Modbus Registers
MV #1	19001
MV #2	19002
MV #3	19003
MV #100	19100



9. Configuring BB2-7010 as a Modbus TCP Slave

The term “server” is often used to describe the Modbus TCP version of a Modbus slave. A server will provide data when a client asks for it. The concept of master/slave is less significant in Modbus TCP because any TCP device can be both master and slave at the same time, and there can be multiple “masters” on the network. That is in contrast with Modbus RTU where there can be only one master and multiple slaves, and each device must be one or the other.

The Modbus TCP server is simply a collection of registers that may contain data. The source of that data in the case of Babel Buster BB2-7010 can be any of several possible sources. It may be read from another Modbus device. Another Modbus device could have put it there by writing to the BB2-7010. The data could have been received by the BACnet client or BACnet server.

9.1 Modbus TCP Device Configuration

Babel Buster 2
BACNET-MODBUS
NETWORK GATEWAY
MODEL BB2-7010-01

CONTROL SOLUTIONS, INC.
MINNESOTA

Data Objects | Modbus | BACnet | **System Setup**

Setup | HTTP Client

Config File | BACnet IP Port | BBMD | Local Host | User

This page allows you to change this device's IP address, and select whether double registers are swapped when returned to a remote client accessing this server.

IP Address	<input type="text" value="192.168.1.64"/>	192.168.1.64	<input type="button" value="Review IP"/>
Subnet Mask	<input type="text" value="255.255.255.0"/>	255.255.255.0	<input type="button" value="Change IP"/>
Gateway	<input type="text" value="192.168.1.1"/>	192.168.1.1	

HTTP Port	<input type="text" value="80"/>	(default 80)	<input type="checkbox"/> Disallow HTTP Query	<input type="button" value="Set Ports"/>
Modbus Port	<input type="text" value="502"/>	(default 502)		
Telnet Port	<input type="text" value="23"/>	(default 23)		

The only local device configuration required for Modbus TCP is to set the IP address of the local device. The standard port for Modbus TCP is 502. This can be changed if necessary.

9.2 Modbus TCP Slave Register Mapping

The mappings shown below are used when the BB2-7010 is treated as a Modbus RTU Slave. All objects are accessed as holding registers. These mappings are also used when the BB2-7010 is treated as a Modbus TCP Server (slave). The local register numbers may be accessed as holding registers. In addition, if the Modicon mapping option is turned on (TCP only), binary points can be accessed as coils.

Analog Input Object

Must be read/written as Floating Point (IEEE 754) register pair, most significant register first.

ANALOG INPUT	
Object	Modbus Registers
AI #1	1 (read 1,2 as pair)
AI #2	3 (read 3,4 as pair)
AI #3	5 (read 5,6 as pair)
AI #300	599 (read 599,600 as pair)

Analog Output Object

Must be read/written as Floating Point (IEEE 754) register pair, most significant register first.

ANALOG OUTPUT	
Object	Modbus Registers
AO #1	1001 (read 1001,1002 as pair)
AO #2	1003 (read 1003,1004 as pair)
AO #3	1005 (read 1005,1006 as pair)
AO #100	1199 (read 1199,1200 as pair)

Analog Value Object

Must be read/written as Floating Point (IEEE 754) register pair, most significant register first.

ANALOG VALUE	
Object	Modbus Registers
AV #1	2001 (read 2001,2002 as pair)
AV #2	2003 (read 2003,2004 as pair)
AV #3	2005 (read 2005,2006 as pair)
AV #100	2199 (read 2199,2200 as pair)

Binary Input Object

Read/written as a single holding register, any non-zero value written will result in bit set.

BINARY INPUT	
Object	Modbus Registers
BI #1	3001
BI #2	3002
BI #3	3003
BI #300	3300

Binary Output Object

Read/written as a single holding register, any non-zero value written will result in bit set.

BINARY OUTPUT	
Object	Modbus Registers
BO #1	4001
BO #2	4002
BO #3	4003
BO #100	4100

Binary Value Object

Read/written as a single holding register, any non-zero

BINARY VALUE	
Object	Modbus Registers
BV #1	5001

value written will result in bit set.

BV #2	5002
BV #3	5003
BV #100	5100

Multi-state Input Object

Read/written as single holding register, treated as unsigned 16-bit integer.

MULTI-STATE INPUT	
Object	Modbus Registers
MI #1	13001
MI #2	13002
MI #3	13003
MI #300	13300

Multi-state Output Object

Read/written as single holding register, treated as unsigned 16-bit integer.

MULTI-STATE OUTPUT	
Object	Modbus Registers
MO #1	14001
MO #2	14002
MO #3	14003
MO #100	14100

Multi-state Value Object

Read/written as single holding register, treated as unsigned 16-bit integer.

MULTI-STATE VALUE	
Object	Modbus Registers
MV #1	19001
MV #2	19002
MV #3	19003
MV #100	19100



10. Using the BB2-7010-02 as an SNMP Server (Agent)

The BB2-7010-02 can act as an SNMP agent or server. You select which BACnet objects are to show up in the MIB, and the MIB is created dynamically as you fill out the list of objects. Once the MIB is created, any standard v1 or v2 SNMP manager can access the data. Integer data is most universally recognized by SNMP. Floating point support is available in the BB2-7010; however, floating point is not standardized and you should test compatibility.



Data Objects Modbus BACnet SNMP System

SNMP Client Diagnostics SNMP Agent

Local MIB Traps Send Traps To

This device can function as an SNMP Agent (or server) providing local data to a remote SNMP Client when it sends a Get request. The remote SNMP Client can also write data using a Set. Note that this functionality is the opposite of the SNMP Client.

Showing to 6 of 6 Update < Prev Next >

Map #	Local SNMP OID	Local Object #	Scale Factor	Local Value	Local Name
1	1.3.6.1.4.1.3815.1.3.1.1.1.2.1	<input type="text" value="AI 1"/>	<input type="text" value="x1"/> <input type="button" value="v"/>	80.7400	Analog Input 1
2	1.3.6.1.4.1.3815.1.3.1.1.1.2.2	<input type="text" value="AI 2"/>	<input type="text" value="x1"/> <input type="button" value="v"/>	0.01208	Analog Input 2
3	1.3.6.1.4.1.3815.1.3.1.1.1.2.3	<input type="text" value="AI 3"/>	<input type="text" value="x1"/> <input type="button" value="v"/>	0.00000	Analog Input 3
4	1.3.6.1.4.1.3815.1.3.1.1.1.2.4	<input type="text" value="AI 4"/>	<input type="text" value="x1"/> <input type="button" value="v"/>	0.00000	Analog Input 4
5	1.3.6.1.4.1.3815.1.3.1.1.1.2.5	<input type="text" value="AI 5"/>	<input type="text" value="x1"/> <input type="button" value="v"/>	0.00000	Analog Input 5
6	1.3.6.1.4.1.3815.1.3.1.1.1.2.6	<input type="text" value="0"/>	<input type="text" value="x1"/> <input type="button" value="v"/>	0.00000	---

Map #

IMPORTANT: The definition of Input versus Output object is from the perspective of the BACnet network. Therefore your SNMP client should Write to Input objects to provide input to BACnet, and Read from Output objects to receive output from BACnet. Attempting to write a BACnet Output object from SNMP will not work properly. You must think of your SNMP manager as the physical I/O being accessed from BACnet. If you want to make your SNMP manager write to an Output object on another BACnet device, use the BACnet client mapping to translate a local Input to remote Output on the BACnet side.

Rule number simply tells you where you're at on the list of the local SNMP Agent's OID maps. Click "next" and "prev" to scroll through the list. To advance directly to a specific map, enter the desired number in the "Showing" box, then click Update.

This page enables SNMP Get/Set to objects indicated on the above map list. The available local OID's are assigned automatically. You may select which local BACnet objects are mapped to these OID's. The only data type supported via the internal SNMP Agent is signed integer, therefore you must use scaling to provide real data as integers. This is an inherent limitation of SNMP which does not have any universally accepted method of transmitting floating point data.

Internal data is multiplied by the scale factor when read by your remote SNMP manager (client). Data written by your SNMP client is divided by the scale factor before being stored internally.

For each local object to be accessed by the remote SNMP Client, enter the local object number and scale factor. The local data and object name will be shown for reference. The data returned to the remote SNMP client will be the indicated local value multiplied by the scale factor, then truncated to integer. Enter an object number, then click Update to add the mapping to the list.

Objects are not immediately available when entered in the list above. When you have finished making changes, click the Reload SNMP button to clear and reload the MIB. The MIB is also automatically reloaded every time you restart this device.

Entering zero (none) for local object effectively deletes the rule even though it will still appear in the list until deleted. Unused rules at the end of the list will always show none as the type.

Local Object is internally a coded number consisting of BACnet object type multiplied by 1000, then added to the object number starting from #1. These are translated into abbreviations that are easy to interpret on the web page as follows:

AI n = Analog Input #n
AO n = Analog Output #n
AV n = Analog Value #n
BI n = Binary Input #n
BO n = Binary Output #n
BV n = Binary Value #n
MI n = Multi-state Input #n
MO n = Multi-state Output #n
MV n = Multi-state Value #n

Object numbers start at #1. The maximum available number varies by object type, and these limits may be found on the System Capacities link from the home/index page (click graphic at top).

Babel Buster 2
BACNET-MODBUS
NETWORK GATEWAY
MODEL BB2-7010-02

CONTROL SOLUTIONS, INC.
MINNESOTA

Data Objects Modbus BACnet **SNMP** System

SNMP Client Diagnostics SNMP Agent

Local MIB Traps Send Traps To

Each variable in the local MIB can have an optional trap associated with it. If a trap is enabled, it is generated according to the following rule for the given local object.

OID # Rule presently tests FALSE

Read local object **AI 1** named **Analog Input 1**

Event is TRUE if the value is this value:

Qualified by this hysteresis value: this minimum On Time: this minimum Off Time:

Trap on True Trap on False Repeat Count: Repeat Time:

OID number simply tells you where you're at on the list of the local SNMP Agent's OID maps. Click "next" and "prev" to scroll through the list. To advance directly to a specific map, enter the desired number in the "Showing" box, then click Update. You cannot proceed to a trap rule for an OID that has not been defined on the Local MIB page.

Select a comparison or test, and click the button for your choice of what the local register should be compared to. Then enter either the fixed value for threshold.

Qualifications are optional, and enabled only when values are nonzero. How hysteresis is applied depends on the comparison. For a test that becomes true if greater than, the test will not return to false until the local register is less than the test value by a margin of at least this hysteresis value. If a test becomes true if less than, it will not return to false until the local register is greater than the test value by a margin of at least this hysteresis value.

On time and off time, if specified, determine how long the condition must be true (on time) or false (off time) before the true or false response is actually taken. Times are given in HH:MM:SS format (hours, minutes, seconds).

The repeat count is the number of times the same trap will be sent when triggered. This number of traps will be sent at approximately 100 millisecond intervals. The repeat time is the delay period between re-transmissions of the trap, or series of traps as determined by the repeat count. Repeat time is in seconds. Example: If repeat count is set to 3, and repeat time is set to 60 seconds, then three trap messages will be sent in a burst and this burst will be repeated once every minute.

Babel Buster 2
BACNET-MODBUS
NETWORK GATEWAY
MODEL BB2-7010-02

CONTROL SOLUTIONS, INC.
MINNESOTA

Data Objects Modbus BACnet **SNMP** System

SNMP Client Diagnostics SNMP Agent

Local MIB Traps Send Traps To

Traps are sent to the devices selected via this page. Identification of the local device as provided to remote SNMP clients is also entered on this page.

Device # Update < Prev Next >

IP Address

System Name Update

System Location

System Contact

Local Community

Traps generated by this device will be sent to port 162 on each IP address listed above. The name, location, and contact listed above may be retrieved by the remote SNMP client. The local community is the name that must be used by the remote SNMP client to write to this device. The name "public" is accepted for reading.



11. Using the BB2-7010-02 as an SNMP Client (Manager)

The BB2-7010-02 has the ability to be an SNMP client. In “master/slave” terms, this would be the master. Configuring the SNMP client starts with defining one or more SNMP devices that will be queried. Then, like the other possible client functions in the BB2-7010-02, you set up read and write maps. A “read map” will use SNMP Get to query the device, and a “write map” will use SNMP Set to write to the device.

The SNMP Client configuration pages are illustrated below along with a summary of how to use them.

This page sets up the network address for a remote SNMP device that will be linked to local objects via the client read and client write maps. The local device acts as an SNMP client (manager) to the remote agents listed below.

Device #

IP Address Local Name:

SNMP Version v1 v2c

SNMP Community

Default Poll Period Seconds

Device Status

Device number simply shows you where you are on the device list. Click “next” and “prev” to scroll through the list.

Remote SNMP devices to be accessed by this device are specified here. Enter the IP address of the remote device, a name to reference in other pages, and a default poll rate. Then click “update”.

This gateway expects to access SNMP devices via the standard port 161.

Connection status will show a non-zero error code if there is a socket error. Possible errors include:

- 5 = Connection failed, unable to bind (usually means remote device not connected or not reachable)
- 81 = Connection in progress (means unsuccessful connect attempt, still trying)
- 95 = Network is unreachable
- 97 = Connection aborted
- 98 = Connection reset by peer
- 103 = Connection timed out
- 104 = Connection refused
- 107 = Host is unreachable

Map #	Remote SNMP OID	Remote Device	Local Object #	Local Object Name
1	1.3.6.1.4.1.3815.1.2.2.1.1.2.1.1.2.1	AddMe Jr. ▾	AI 1	Analog Input 1
2	1.3.6.1.4.1.3815.1.2.2.1.1.2.1.1.2.2	AddMe Jr. ▾	AI 2	Analog Input 2
3	1.3.6.1.4.1.3815.1.2.2.1.1.2.1.1.2.3	AddMe Jr. ▾	AI 3	Analog Input 3
4		None ▾	0	—

Rule number simply tells you where you're at on the list of OID maps. Click "next" and "prev" to scroll through the list. To advance directly to a specific map, enter the desired number in the "Showing" box, then click Update.

Rules entered on this page only read data from remote devices. Go to the Client Write Map to write data to those devices. The full parameter set is different for read versus write.

An abbreviated version of a list of rules is shown on this page. Any of the parameters shown may be changed here and registered by clicking the Update button. To view and/or modify the complete set of parameters, click on the map number in the left most column.

For each remote OID to be read, enter the full SNMP OID and location (device). The names in the device list are defined in the Devices page.

The object name is optional and used only for display purposes, but is also returned as the object name to the remote BACnet client.

Entering zero (none) for local object effectively deletes the rule even though it will still appear in the list until deleted. Unused rules at the end of the list will always show none as the type.

Local Object is internally a coded number consisting of BACnet object type multiplied by 1000, then added to the object number starting from #1. These are translated into abbreviations that are easy to interpret on the web page as follows:

AI n = Analog Input #n
 AO n = Analog Output #n
 AV n = Analog Value #n
 BI n = Binary Input #n
 BO n = Binary Output #n
 BV n = Binary Value #n
 MI n = Multi-state Input #n
 MO n = Multi-state Output #n
 MV n = Multi-state Value #n

Object numbers start at #1. The maximum available number varies by object type, and these limits may be found on the System Capacities link from the home/index page (click graphic at top).

This page creates a map entry that reads data from a remote SNMP agent for processing here.

Map #

Read OID: from

Then apply scale: and offset:

Save in local object # named Repeat this process every seconds.

Apply this default value: after read failure(s).

Initial COV increment: Initial COV Period: (sec.) Units:

Client Read Maps Enabled:

Rule number simply tells you where you're at on the list of OID maps. Click "next" and "prev" to scroll through the list. To advance directly to a specific map, enter the desired number in the "Map #" box, then click Update.

For each remote OID to be read, enter the full OID and location (device). The names in the device list are defined in the Devices page.

When the remote OID is read, data may be manipulated before being written to the local object. The result will be multiplied by the scale factor if any non-zero scale factor is given. The offset is then added and this final result is written to the local object number given. The name is optional and used only for display purposes (but will also be returned as the object name to the BACnet client).

The periodic poll time determines how often the remote OID will be read. This number, if nonzero, will override the default poll time given in the Devices page for the remote device being read.

The default value will be stored into the local object after the given number of read failures if the fail count

is non-zero. Setting the count to zero will disable the default, and the object will retain the most recent value obtained.

Delete will remove the rule number shown in the "Map #" box. Insert will insert a new rule before the rule number shown, and is used for placing rules between existing rules. It is not necessary to use Insert to add rules to the bottom of the list or to define any rule presently having zero for a source object or "none" for remote type.

Entering zero (for none) for local object effectively deletes the rule even though it will still appear in the list until deleted. Unused rules at the end of the list will always show none as the type. If you wish to prevent these from being displayed, reduce the number of rules enabled.

Initial COV increment and period will only apply if a BACnet client subscribes to COV notification from the BACnet object assigned to this SNMP client map. These properties may be overwritten by the BACnet client(s) at any time. The values shown here are initial values, not necessarily the current values. (Note: COV increment only applies to Analog objects, all changes are reported for Binary or Multistate objects.)

Units default to no_units, but you may select any of the available BACnetEngineeringUnits values. This value will simply be read by the BACnet client when the units property is requested from the object this OID maps to. The units have no bearing on calculations performed. You must select appropriate scale and offset values to make any required translation between SNMP units and BACnet units. Units are only valid for Analog objects.

The number of rules enabled simply limits the scope of rule review so that you do not have to review a lot of unused rules. If the displayed rules are used up and you need more, increase the enabled number.

Write local objects out to remote SNMP OIDs. This page creates a map entry that writes data remote SNMP agents from data contained here. Click on map number to see more detail and insert/delete rules.

Showing to 2 of 2

Map #	Local Object #	Remote SNMP OID	Remote Data Type	Remote Device	Local Object Name
1	BO1	1.3.6.1.4.1.3815.1.2.2.1.1.2.1.2.1	Unsigned	AddMe Jr.	Binary Output 1
2	0		Undefined	None	—

Rule number simply tells you where you're at on the list of OID maps. Click "next" and "prev" to scroll through the list. To advance directly to a specific map, enter the desired number in the "Showing" box, then click Update.

Rules entered on this page only write data to remote devices. Go to the Client Read Map to read data from those devices. The full parameter set is different for read versus write.

An abbreviated version of a list of rules is shown on this page. Any of the parameters shown may be

changed here and registered by clicking the Update button. To view and/or modify the complete set of parameters, click on the map number in the left most column.

Data from the local object given will be multiplied by the scale factor before being written. For each remote OID to be written, enter the register type, format, number, and location (device). The names in the device list are defined in the Devices page. The name is optional and used only for display purposes.

Important note about data type: SNMP does not have a universally accepted representation for floating point. The most commonly used means of representing real data is scaled integers, and this method is supported by BB2-7010. IEEE 754 is not recognized as an SNMP standard and is not used. X.690 defines an encoding for real data, but it is inefficient and little used. A common recommendation is to use ASCII string representation of floating point data, and this method is supported by BB2-7010 (Octet String Num). Another known but application specific implementation is the ASN OPAQUE FLOAT used in netsnmp applications. This method is also supported by BB2-7010 but should be tested to confirm compatibility.

Selecting "none" for remote type effectively deletes the rule even though it will still appear in the list until deleted. Unused rules at the end of the list will always show none as the type.

Local Object is internally a coded number consisting of BACnet object type multiplied by 1000, then added to the object number starting from #1. These are translated into abbreviations that are easy to interpret on the web page as follows:

AI n = Analog Input #n
AO n = Analog Output #n
AV n = Analog Value #n
BI n = Binary Input #n
BO n = Binary Output #n
BV n = Binary Value #n
MI n = Multi-state Input #n
MO n = Multi-state Output #n
MV n = Multi-state Value #n

Object numbers start at #1. The maximum available number varies by object type, and these limits may be found on the System Capacities link from the home/index page (click graphic at top).

Babel Buster 2
BACNET-MODBUS
NETWORK GATEWAY
MODEL BB2-7010-02

CONTROL SOLUTIONS, INC.
MINNESOTA

Data Objects Modbus BACnet **SNMP** System

SNMP Client Diagnostics SNMP Agent

Devices Client Read Map Client Write Map

This page creates a map entry that writes data to remote SNMP agents from data contained here.

Map #

Read local object # named

Apply default value of at power-up and/or when seconds have elapsed with no host update.

Write remote OID any time local object has changed by or when seconds have elapsed with no change.

Otherwise write remote OID unconditionally. In any event, when writing remote OID, apply local object data as follows:

Apply scale: and offset:

Write OID as at

Repeat this process at least no more than every seconds.

Initial COV increment: Initial COV Period: (sec.) Units:

Initial Relinquish Default:

Client Write Maps Enabled:

Rule number simply tells you where you're at on the list of OID maps. Click "next" and "prev" to scroll through the list. To advance directly to a specific map, enter the desired number in the "Map #" box, then click Update.

The local object data may be written periodically, or when it changes, or both. To send upon change (send on delta), check the first box and enter the amount by which the local object must change before being written to the remote device. To guarantee that the remote OID will be written at least occasionally even if the data does not change, check the second box and enter some amount of time. This time period will be referred to as the "maximum quiet time".

Data from the local object may be manipulated before being written to the remote OID. The local data is first multiplied by the scale factor. The offset is then added to it. The data is then sent to the remote SNMP agent. Enter the full OID to be written, the SNMP ASN data type to be written (select from list), and the location (device). The names in the device list are defined in the Devices page.

Important note about data type: SNMP does not have a universally accepted representation for floating point. The most commonly used means of representing real data is scaled integers, and this method is supported by BB2-7010. IEEE 754 is not recognized as an SNMP standard and is not used. X.690 defines an encoding for real data, but it is inefficient and little used. A common recommendation is to use ASCII string representation of floating point data, and this method is supported by BB2-7010 (Octet String Num). Another known but application specific implementation is the ASN OPAQUE FLOAT used in netsnmp applications. This method is also supported by BB2-7010 but should be tested to confirm compatibility.

The repeat time may determine how often the remote OID will be written. If send on delta and maximum quiet time are not checked above, clicking the "at least" button will establish a periodic update time. If send on delta is used and you wish to limit the network traffic in the event changes are frequent, click the "no more than" button and enter the minimum time that should elapse before another write to the remote device.

Delete will remove the rule number shown in the "Map #" box. Insert will insert a new rule before the rule number shown, and is used for placing rules between existing rules. It is not necessary to use Insert to add rules to the bottom of the list or to define any rule presently having zero/none for a source object.

Selecting "none" for remote type effectively deletes the rule even though it will still appear in the list until deleted. Unused rules at the end of the list will always show none as the type. If you wish to prevent these from being displayed, reduce the number of rules enabled.

Initial COV increment and period will only apply if a BACnet client subscribes to COV notification from the BACnet object assigned to this Modbus map. These properties may be overwritten by the BACnet client(s) at any time. The values shown here are initial values, not necessarily the current values. (Note: COV increment only applies to Analog objects, all changes are reported for Binary or Multistate objects.)

Units default to no_units, but you may select any of the available BACnetEngineeringUnits values. This value will simply be read by the BACnet client when the units property is requested from the object this OID maps to. The units have no bearing on calculations performed. You must select appropriate scale and offset values to make any required translation between SNMP units and BACnet units. Units are only valid for Analog objects.

Initial Relinquish Default may be set here, but may be overwritten by the BACnet client at any time. This window reflects the initial value, not the current value. (Note: Relinquish Default only applies to commandable Output objects, and does not apply to Input or Value objects.)

The number of rules enabled simply limits the scope of rule review so that you do not have to review a lot of unused rules. If the displayed rules are used up and you need more, increase the enabled number.

Babel Buster 2
BACNET-MODBUS
NETWORK GATEWAY
MODEL BB2-7010-02

CONTROL SOLUTIONS, INC.
MINNESOTA

Data Objects Modbus BACnet **SNMP** System

SNMP Client Diagnostics SNMP Agent

Errors: Read Maps Errors: Write Maps

This page displays errors, if any, reported by the remote server upon attempts to read from that device.

<< Top Next >

Map #	Remote OID	Remote Device	Local Name	Error Code
--	---	---	---	0

Reset Errors

Errors for SNMP client read maps are shown on this page. Only those maps with errors to report are listed. Refer to the code and class lists below for interpretation.

Common error codes for the SNMP client are as follows:

9 = No response from remote Agent (server)

10 = Unable to interpret data

11 = Reply does not match request

Other error codes are possible but improbable. Codes in the 80-120 range indicate socket errors; however, because SNMP uses UDP/IP, which is "connectionless", socket errors would indicate something internal is seriously broken.



12. HTTP Client

The Babel Buster BB2-7010-01 can function as an HTTP Client to push data to a specially programmed remote server such as the web portal you find at www.logmydata.com. You may develop your own web server for this purpose. Contact Control Solutions via support ticket for guidance on developing such a web server application.

Once you have access to a web server application ready to receive data, you simply list the objects you wish to send to the server in the list illustrated below.

The screenshot shows the Babel Buster 2 web interface. The top navigation bar includes tabs for Data Objects, Modbus, BACnet, and System Setup. The System Setup tab is active, and the HTTP Client sub-tab is selected. Below the navigation, there is a section titled 'Data Points' with a description: 'This page displays a list of points being logged via the HTTP Client.' A control bar shows 'Showing points from' followed by a text input field containing '1', and buttons for 'Update', '< Prev', and 'Next >'. Below this is a table with the following data:

Point #	Local Object	Object Name
1	AI 1	Volts
2	AI 2	Amps
3	AI 3	Hertz
4	AI 4	Watts
5	0	---

There are additional settings that need to be configured on the Local Network page if the HTTP Client is used. This is the only time these settings need to be configured. You will need to provide the IP address(es) of your DNS Server(s). You will need to provide the URL of the web server that is to receive data, and the web page that the data is to be submitted to. The Client ID uniquely identifies this device when you have more than one reporting to the same web portal. The minimum additional settings are illustrated below.



Data Objects	Modbus	BACnet	System Setup	
	Setup	HTTP Client		
Config File	BACnet IP Port	BBMD	Local Host	User

This page allows you to change this device's IP address, and select whether double registers are swapped when returned to a remote client accessing this server.

IP Address	<input type="text" value="192.168.1.64"/>	192.168.1.64	<input type="button" value="Review IP"/>
Subnet Mask	<input type="text" value="255.255.255.0"/>	255.255.255.0	<input type="button" value="Change IP"/>
Gateway	<input type="text" value="192.168.1.1"/>	192.168.1.1	
Static DNS1	<input type="text" value="68.87.77.130"/>	68.87.77.130	<input type="button" value="Set DNS"/>
Static DNS2	<input type="text" value="68.87.72.130"/>	68.87.72.130	
Proxy Server	<input type="text"/>		<input type="button" value="Set Proxy"/>
Proxy Port	<input type="text" value="0"/>		
HTTP Port	<input type="text" value="80"/> (default 80)	<input type="checkbox"/> Disallow HTTP Query	<input type="button" value="Set Ports"/>
Modbus Port	<input type="text" value="502"/> (default 502)		
Telnet Port	<input type="text" value="23"/> (default 23)		
Client Update Host	<input type="text" value="logmydata.net"/>	<input checked="" type="checkbox"/> Enable	<input type="button" value="Update"/>
Log Page	<input type="text" value="/ireport.php"/>		
Log Parameters	<input type="text"/>	(optional)	
Configuration Page	<input type="text"/>		
Update Timeout	<input type="text" value="60"/>	Client ID <input type="text" value="900064"/>	HTTP Port <input type="text" value="80"/>
Uptime 1,02:29:30			



13. BBMD Configuration

BBMD stands for BACnet Broadcast Management Device. Messages such as "Who-Is" and "I-Am" are broadcast. Most routers, however, do not pass broadcast messages along. The BBMD solves this problem by explicitly directing broadcast messages to a specific IP address.

A Broadcast Distribution Table (BDT) defines a list of IP addresses that the BBMD should send broadcast messages to. It is important to note that a BBMD only forwards broadcast messages. It does not do full routing. If you are attempting to connect two networks across a NAT router, you must get a full BACnet Router to accomplish this. For this reason, the BDT has limited usefulness when only BBMD is present. The BB2-7010 only includes BBMD, not full routing. Use the BB2-7030 if you need full routing.

If you have a remote BB2-7010 that needs to connect via router, including NAT router, to a local network, use Foreign Device Registration. There will typically be a master device, such as operator station or other front end, that includes BBMD. The IP address of this device is the one that should be given as the BBMD address for foreign device registration.

Broadcast distribution will result in device discover, but you will not be able to read/write properties in the remote device without full routing. Foreign device registration does result in being able to fully communicate with the foreign device from the local network.

The screen shot below shows a BB2-7010 that has successfully registered with a BBMD at the IP address shown.



[Data Objects](#)
[Modbus](#)
[BACnet](#)
[System Setup](#)

[Setup](#)
[HTTP Client](#)

[Config File](#)
[BACnet IP Port](#)
[BBMD](#)
[Local Host](#)
[User](#)

This page displays BACnet IP port settings.

Broadcast Distribution Table

[Edit](#)

[Refresh](#)

Broadcast Address:Port	Broadcast Mask
192.168.1.191:47808	FFFFFF00

Foreign Device Table

[Refresh](#)

Local Device's Registration as a Foreign Device at Remote Location

BBMD Time To Live (seconds) (Zero disables foreign registration)

[Save](#)

BBMD IP Address, Port **BBMD is registered.**

Foreign Devices Registered Locally	Time to Live
---	---



14. Object Properties

14.1 Data Object Properties (Analog, Binary, Multi-state)

The following properties are found in the Analog, Binary, and Multi-state types of Input, Output, and Value objects. Some properties apply only to certain object types as noted where applicable.

Property	Encoding
Object_Identifier (75)	BACnetObjectIdentifier
Object_Name (77) (W)	CharacterString "Analog Input <i>n</i> "
Object_Type (79)	BACnetObjectType ENUMERATED: analog-input (0) analog-output (1) analog-value (2) binary-input (3) binary-output (4) binary-value (5) device (8) multi-state-input (13) multi-state-output (14) multi-state-value (19)
Present_Value (85) (W)	REAL (analog objects) ENUMERATED (binary objects) Unsigned (multi-state objects) (no index) (priority required when writing commandable objects) (input objects writeable only when out of service)
Status_Flags (111)	BACnetStatusFlags BIT STRING: fault(1), out-of-service(3)
Event_State (36)	BACnetEventState ENUMERATED: normal(0), fault(1)
Reliability (103)	BACnetReliability ENUMERATED: normal(0) <i>Vendor specific:</i> no response (64) crc error (65) exception, illegal function code (66) exception, illegal data address (67) exception, illegal data value (68)

	exception, code+65, rarely used (69..79) configuration property fault (80) exception, code not recognized (81) BACnet client read/write timeout (82) BACnet client received error response from slave (83) SNMP client received no response from agent (84) SNMP client unable to parse data (85) SNMP client reply does not match request (86)
Out_Of_Service (81) (W)	BOOLEAN
COV_Increment (22) (W)	REAL (analog objects only)
Priority_Array (87)	BACnetPriorityArray (commandable objects only) SEQUENCE SIZE (16) OF BACnetPriorityValue REAL (each element, analog output objects) ENUMERATED (each element, binary output objects) Unsigned (each element, multi-state output objects)
Relinquish_Default (104) (W)	REAL (analog objects) ENUMERATED (binary objects) Unsigned (multi-state objects)
Polarity (84)	BACnetPolarity (binary objects only) ENUMERATED: normal(0)
Number_Of_States (74)	Unsigned (multi-state objects only)
Units (117)	BACnetEngineeringUnits (analog objects only)

14.2 Device Object Properties

The following properties are found in the Device object of the BB2-7010. In addition to standard Device properties.

Property	Encoding
Object_Identifier (75)	BACnetObjectIdentifier
Object_Name (77)	CharacterString
Object_Type (79)	BACnetObjectType ENUMERATED: device (8)
System_Status (112)	BACnetDeviceStatus
Vendor_Name (121)	CharacterString
Vendor_Identifier (120)	Unsigned16 (should always return 208)
Model_Name (70)	CharacterString
Firmware_Revision (44)	CharacterString
Application_Software_Version (12)	CharacterString
Protocol_Version (98)	Unsigned

Protocol_Revision (139)	Unsigned
Protocol_Services_Supported (97)	BACnetServicesSupported
Protocol_Object_Types_Supported (96)	BACnetObjectTypesSupported
Object_List (76)	BACnetARRAY[N] of BACnetObjectIdentifier
Max_APDU_Length_Accepted (62)	Unsigned
Segmentation_Supported (107)	BACnetSegmentation
APDU_Timeout (11)	Unsigned
Number_Of_APDU_Retries (73)	Unsigned
Device_Address_Binding (30)	List of BACnetAddressBinding
Database_Revision (155)	Unsigned



15. Trouble Shooting

The following discussion focuses on Modbus Master functionality. Troubleshooting for the BACnet or SNMP clients will be very similar and you should be able to use the examples here to help trouble shoot.

15.1 Modbus RTU Trouble Shooting

This discussion assumes you want the Babel Buster BB2-7010 to be the Modbus Master (most common use). Let's review the setup procedure for a single Modbus read map. We suggest starting with one register. Once you get that working, proceed to fill up the table.

First, go to the Local Device page and make sure you have the baud rate set, and parity (if any) selected. If you do not know what baud rate your Modbus device is set to, consult that manufacturers documentation before proceeding.

Make sure the Master button is clicked. Start with a liberally slow timeout, like 0.5 second just to be rather certain you do not have timeout problems. It is rare to see a piece of working equipment take longer than half a second to respond to a Modbus master. *Setting the timeout to zero, however, will guarantee failure* since the master will miss every reply by not waiting at all for it.

This page displays configuration parameters for the Modbus RTU serial port.

Baud Rate: 19200 Parity: None, 1 Stop Bit Update

I am the Master **I am a Slave**

Parameters for RTU Master: Parameters for RTU Slave:

Default Poll Rate: 2.000 Seconds My Address or Unit #: 0

Timeout: 1.000 Seconds Double registers are swapped

Use FC 5/6 instead of 15/16 for unit numbers (slave addresses) starting at 0

Use FC 5/6 and 15/16 by count for unit numbers (slave addresses) starting at 0

Next, go to the RTU Read Map page (below) . To get started, select a register type and format, a register number, a unit # (aka slave ID or slave address), and a local object number to store the data in. If any of the red check marks shown below are "none" or zero, you will get no action even attempted. Make sure the Unit # (slave ID or slave address) matches whatever you have your Modbus device set to. If you are uncertain what address it is set to, you need to consult the manufacturer's documentation for that

equipment before proceeding.

The following example shows the only non-zero entries required (the 5 check marks) to successfully read holding register #22 from unit #1 and store the data in Analog Input #10. Once these (or comparable) entries have been made, click the Update button.

Showing 1 to 2 of 2 Update < Prev Next >

Map #	Remote Type	Remote Register Format	Remote Register #	Remote Unit #	Scale	Local Object #	Name
1	Holding Register	Int 16-bit	22	1	0.00000	AI 10	Modbus Reg 22
2	None	Int 16-bit	0	0	0.00000	0	---

At this point, you can go to the data page (below) and see if you have data showing up. If you get no data, there is a problem. The confirmation that you are probably getting no data is the "time since last update". In this example, we see 95 seconds have elapsed. We are attempting to update every 2 seconds, so obviously data retrieval is not happening.

RTU Unit # 1 Showing 1 to 1 of 1 Update < Prev Next >

Dir.	Reg. Type	Remote Reg. #	Register Name	Local Object #	Hex	Update	Register Data	Time since Last update
From	Holding Reg	00022	Modbus Reg 22	AI 10	<input type="checkbox"/>	<input type="checkbox"/>	0.00000	95.227

If you are getting no data, check the Error Codes page (below). Here we see that the "No Responses" is about equal to the "Total Messages". This means we are not getting anything back from the Modbus slave. If you are certain all of the above setup is correct, the only conclusion you (or we) can come to at this point is that there is a wiring problem, or the slave is not responding or not configured correctly. Review wiring information, and check the slave configuration. If you get a high number of CRC errors, this is also an indication of likely wiring problem.

This page displays error codes encountered in processing reads and writes via the Modbus RTU serial port.

Showing devices from 1  Update < Prev Next >

Unit #	Reset -->	Read Error	Offending Read Map #	Reset -->	Write Error	Offending Write Map #	Reset -->	Total Messages	No Responses	CRC Errors	Exceptions
1	<input type="checkbox"/>	5/0	1	<input type="checkbox"/>	0/0	0	<input type="checkbox"/>	222 =	221	0	0
2	<input type="checkbox"/>	0/0	0	<input type="checkbox"/>	0/0	0	<input type="checkbox"/>	0	0	0	0

If, instead of No Responses, the count you see is Exceptions, this means you are communicating just fine, but the slave is telling you that your request is incorrect. You are asking for a register number that does not exist, using the incorrect register type, etc. Something about configuration is not right if you get Exception errors.

If the Error Codes page is showing a problem, this will also be reflected by the BACnet object reliability code and status bits as illustrated below.

This page displays data as presently found in the local objects maintained by this device.

Analog Input Objects Showing objects from 10 Refresh < Prev Next >

Object	Object Name	Out of Service	Present Value	Reliability	Status	Units
<u>10</u>	Modbus Reg 22	N	0.00000	64	0,1,0,0	no_units

Once the problem is resolved and you are successfully receiving data, the BACnet object will reflect a reliability code of zero and the fault bits will be clear.

This page displays data as presently found in the local objects maintained by this device.

Analog Input Objects Showing objects from 10 Refresh < Prev Next >

Object	Object Name	Out of Service	Present Value	Reliability	Status	Units
<u>10</u>	Modbus Reg 22	N	45.000	0	0,0,0,0	no_units

15.2 Modbus TCP Trouble Shooting

This discussion assumes you want the Babel Buster BB2-7010 to be the Modbus TCP Master. Let's review

the setup procedure for a single Modbus read map. We suggest starting with one register. Once you get that working, proceed to fill up the table.

First, go to the IP Network Devices page and make sure you have the IP of the intended Modbus TCP slave entered, along with a local name by which it will be referenced.

This page sets up the network address and optional device parameters for a remote Modbus/TCP device that will be linked to local objects via the client read and client write maps. The local device acts as a Modbus master to the remote devices listed below.

Device # 1 Update < Prev Next >

IP Address 192.168.1.10 Port 502 Local Name: Test Device

Unit (optional) 0 Use FC 5/6 instead of 15/16 Use FC 5/6 and 15/16 by count

Low register is first for multiple registers Connection Status

Default Poll Period 2.0 Seconds 0

Next, go to the Click Read Map page (below). To get started, select a register type and format, a register number, a device (from list created above), and a local object number to store the data in. If any of the red check marks shown below are "none" or zero, you will get no action even attempted. Make sure the IP address (in the device list) matches whatever you have your Modbus device set to. If you are uncertain what IP address it is set to, you need to consult the manufacturer's documentation for that equipment before proceeding.

The following example shows the only non-zero entries required (the 5 check marks) to successfully read holding register #23 from "Test Device" and store the data in Analog Input #11. Once these (or comparable) entries have been made, click the Update button.

Read remote registers into local objects. This page creates a map entry that reads data from one or more remote Modbus/TCP servers for processing here. Click on map number to see more detail and insert/delete rules.

Showing 1 to 2 of 2 Update < Prev Next >

Map #	Remote Type	Remote Register Format	Remote Register #	Remote Device	Scale	Local Object #	Name
1	Holding Register	Int 16-bit	23	Test Device	0.00000	AI 11	TCP Reg 23
2	None	Int 16-bit	0	None	0.00000	0	---

At this point, you can go to the Data Objects page (below) and see if you have data showing up. If you get no data, there is a problem, and the problem will be further indicated by the BACnet object reliability code being non-zero, and the fault status bit set. The meaning of the various possible reliability codes is listed in the Quick Help section at the bottom of each Data Object page. Code 64 means "no response" from the Modbus device.

This page displays data as presently found in the local objects maintained by this device.

Analog Input Objects Showing objects from 11 Refresh < Prev Next >

Object	Object Name	Out of Service	Present Value	Reliability	Status	Units
11	TCP Reg 23	N	0.00000	64	0,1,0,0	no_units

If you are getting no data, check the Error Codes page (below). Here we see that the "No Responses" is some number greater than total messages. Zero total messages means we never succeeded in making a TCP connection.

This page displays error codes encountered in processing Modbus Client reads and writes via the Modbus TCP connection(s).

 Update

Device	Reset -->	Read Error	Offending Read Map #	Reset -->	Write Error	Offending Write Map #	Reset -->	Total Messages	No Responses	Exceptions
1	<input type="checkbox"/>	0/5	1	<input type="checkbox"/>	0/0	0	<input type="checkbox"/>	0	7	0

If you return to the TCP Devices page at this point, you may notice that the Connection Status is some non-zero value. Status zero means no problem has been detected. A non-zero code means there is a problem with the connection.

This page sets up the network address and optional device parameters for a remote Modbus/TCP device that will be linked to local objects via the client read and client write maps. The local device acts as a Modbus master to the remote devices listed below.

Device # 1 Update < Prev Next >

IP Address 192.168.1.10 Port 502 Local Name: Test Device

Unit (optional) 0 Use FC 5/6 instead of 15/16 Use FC 5/6 and 15/16 by count

Low register is first for multiple registers Connection Status

Default Poll Period 2.0 Seconds 5

Connection status will show a non-zero error code if there is a socket error. The most common errors include:

5 = Connection failed, unable to bind (usually means remote device not connected or not reachable)

- 81 = Connection in progress (means unsuccessful connect attempt, still trying)
- 95 = Network is unreachable
- 97 = Connection aborted
- 98 = Connection reset by peer
- 103 = Connection timed out
- 104 = Connection refused
- 107 = Host is unreachable



16. WiFi Sensor Setup - PointSix, AirTest

The BB2-7010-06 is an enhancement to the standard BB2-7010-02 which adds recognition of PointSix and AirTest WiFi sensors that transmit data to a UDP port which the user may configure. The sensor packets utilize the PointSix data packet format. Refer to PointSix documentation for setup of the sensor itself. The BB2-7010-06 will make the PointSix sensor data available as BACnet objects (and Modbus registers or SNMP OID's).

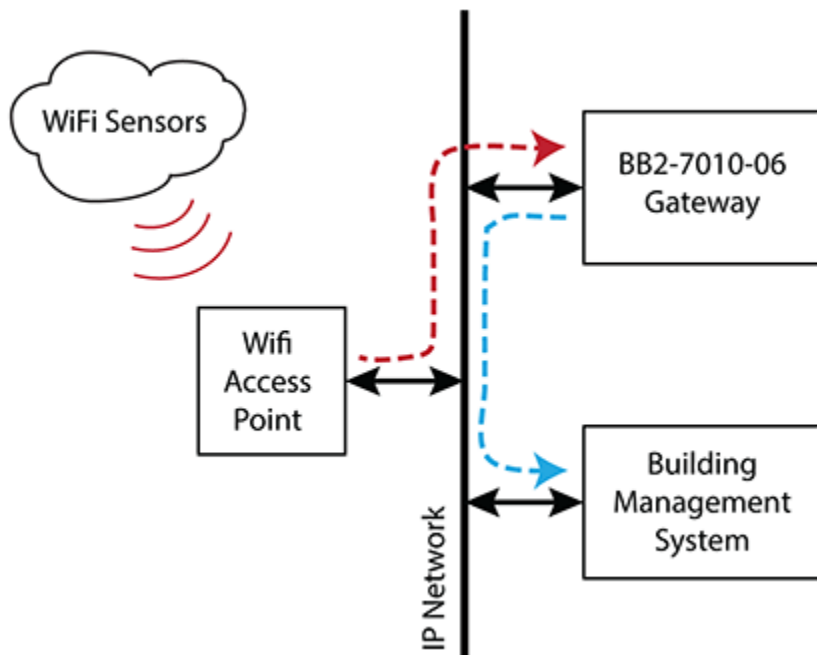

A standard generic WiFi access point is used to connect the WiFi sensors to the wired network. The access point should be placed where it has access to the wired network, but also where it will have good reception of the WiFi sensor signals. Typically, the BB2-7010-06 gateway will be located inside a control panel, but the WiFi access point will be located outside the control panel and potentially some distance from the panel.

16.1 Sensor Network Settings

The WiFi sensors need to initially be configured using the sensor configuration utility. One of the required settings is the IP address of the server to which the sensor should send data. That IP address will be the address of the BB2-7010-06 gateway which is set on the Local Host page shown here. If NAT routers are placed between the sensors and the gateway, then use IP addresses provided by the IT technician that set up the router.

Data Objects **Modbus** **BACnet** **SNMP** **System**

Setup **Sensors**

Config File **BACnet IP Port** **BBMD** **Local Host** **User**

This page allows you to change this device's IP address, and select whether double registers are swapped when returned to a remote client accessing this server.

IP Address 192.168.1.148

Subnet Mask 255.255.255.0

Gateway 192.168.1.1

MAC Address 00:40:9D:39:C1:A6

HTTP Port (default 80)

Uptime 1,17:19:37

UDP Sensor Port (default 6767)

UDP Port Status 0

The sensors send data to UDP port 6767 by default. To change that, go to the Network configuration page where the gateway's IP address is set, and select a different UDP port if desired.

16.2 Sensor Configuration

The screen illustrated below is used to set up recognition of the WiFi sensor packets.



Data Objects **Modbus** **BACnet** **SNMP** **System**

Setup **Sensors**

Sensor Data **Sensor Setup**

WiFi sensors that will be recognized by the system are entered here.

Showing to 15 of 200

Sensor	Sensor S/N	Timeout (minutes)	Chan 1 Object #	Chan 1 Scale	Chan 1 Offset	Chan 2 Object #	Chan 2 Scale	Chan 2 Offset
1	<input type="text" value="E1A3D018"/>	<input type="text" value="15"/>	<input type="text" value="AI 1"/>	<input type="text" value="1.80000"/>	<input type="text" value="32.0000"/>	<input type="text" value="AI 2"/>	<input type="text" value="1.80000"/>	<input type="text" value="32.0000"/>
2	<input type="text" value="E22B4008"/>	<input type="text" value="15"/>	<input type="text" value="AI 3"/>	<input type="text" value="0.00000"/>	<input type="text" value="0.00000"/>	<input type="text" value="AI 4"/>	<input type="text" value="1.80000"/>	<input type="text" value="32.0000"/>
3	<input type="text" value="E2044005"/>	<input type="text" value="15"/>	<input type="text" value="AI 5"/>	<input type="text" value="1.80000"/>	<input type="text" value="32.0000"/>	<input type="text" value="0"/>	<input type="text" value="0.00000"/>	<input type="text" value="0.00000"/>
4	<input type="text"/>	<input type="text" value="0"/>	<input type="text" value="0"/>	<input type="text" value="0.00000"/>	<input type="text" value="0.00000"/>	<input type="text" value="0"/>	<input type="text" value="0.00000"/>	<input type="text" value="0.00000"/>

Enter the 8-character hexadecimal serial number of the sensor packet whose data is to be received. Select local BACnet objects where data from channels 1 and 2 of the sensor should be stored. BACnet objects should be either Analog Input or Analog Value. Do not use any other object type. Scaling of raw data to

engineering units will be performed automatically based on the enumeration code returned by the sensor. The scale and offset values shown here are applied on top of the scaling native to the sensor. For example, sensors returning temperature will always return degrees Celsius. To convert to Fahrenheit instead, apply scale and offset as illustrated above.

The timeout, in minutes, is optional. If zero, the timeout will not be monitored. If non-zero, and the time since last transmission exceeds this time in minutes, then the BACnet objects assigned to this sensor will reflect a Fault status.

The sensors have high/low alarm capability. If the alarms are not being used, then the only setup needed is on the tabular list illustrated above. To set up alarms, click on the sensor number in the first column. This will take you to the extended alarm setup page illustrated below.

Data Objects
Modbus
BACnet
SNMP
System

Setup
Sensors

Sensor Data
Sensor Setup

WiFi sensors that will be recognized by the system are entered here.

Sensor #

Device	Serial Number <input style="width: 100%;" type="text" value="E1A3D018"/>	Transmit Period <input style="width: 50%;" type="text" value="300"/>	
	Timeout <input style="width: 50%;" type="text" value="15"/>	Hysteresis <input style="width: 50%;" type="text" value="5"/>	

Channel 1 Data	Data Object <input style="width: 100%;" type="text" value="AI 1"/>	Scale <input style="width: 50%;" type="text" value="1.80000"/>	
		Offset <input style="width: 50%;" type="text" value="32.0000"/>	

Channel 1 Alarms	High Alarm		Low Alarm
	Setpoint Object <input style="width: 100%;" type="text" value="0"/>		Setpoint Object <input style="width: 100%;" type="text" value="0"/>
	Setpoint Value <input style="width: 100%;" type="text" value="85.0000"/>		Setpoint Value <input style="width: 100%;" type="text" value="65.0000"/>
	Alarm Time <input style="width: 50%;" type="text" value="1"/>		Alarm Time <input style="width: 50%;" type="text" value="1"/>
	Status Object <input style="width: 100%;" type="text" value="BI 1"/>		Status Object <input style="width: 100%;" type="text" value="BI 2"/>

Channel 2 Data	Data Object <input style="width: 100%;" type="text" value="AI 2"/>	Scale <input style="width: 50%;" type="text" value="1.80000"/>	
		Offset <input style="width: 50%;" type="text" value="32.0000"/>	

Channel 2 Alarms	High Alarm		Low Alarm
	Setpoint Object <input style="width: 100%;" type="text" value="AO 1"/>		Setpoint Object <input style="width: 100%;" type="text" value="AO 2"/>
	Setpoint Value <input style="width: 100%;" type="text" value="0.00000"/>		Setpoint Value <input style="width: 100%;" type="text" value="0.00000"/>
	Alarm Time <input style="width: 50%;" type="text" value="1"/>		Alarm Time <input style="width: 50%;" type="text" value="1"/>
	Status Object <input style="width: 100%;" type="text" value="BI 3"/>		Status Object <input style="width: 100%;" type="text" value="BI 4"/>

The same sensor setup information found on the tabular list is also available here, in addition to alarm settings. Enabling an alarm requires setting the Alarm Time to a non-zero value. User scaling entered here is applied to alarm setpoints, as well as additional internal scaling based on sensor type and its enumeration code. Therefore, the example here will display temperatures in Fahrenheit, and alarm setpoints will also then be entered as Fahrenheit.

The sensor Transmit Period is entered in seconds. The Hysteresis is entered as a raw count. This value is not scaled since the same hysteresis is applied to both sensor channels, which may have different units. The raw count is A/D count at the sensor. As an example, a single 'count' for an RTD sensor is 0.0977

degrees C. Refer to the sensor data sheet for actual scaling information. If transmit period and hysteresis are left as zero on this page, the gateway will send back whatever settings it got from the sensor for those parameters, which would have been initially set using the sensor configuration utility (independent of anything the BB2-7010-06 does).

Analog Input is the most suitable BACnet object for recording data values read by sensors. Analog Value would also be an appropriate choice, although with no particular advantage over Analog Input. Analog Output is not a suitable choice for sensor values since these objects are meant to be written to BB2-7010, not read from. Analog Input is typically a sensor object, while Analog Output is typically an actuator object.

Sensor alarm setpoints can be fixed values that are stored in the XML configuration file, or setpoints can be provided dynamically by an external system. Sensor alarm setpoints can be taken from an Analog Value object or Analog Output object. You would not use an Analog Input object for alarm setpoints since you cannot write to an Analog Input. The notation "Input" means input from sensor hardware, or input to the network. The notation "Output" means output to sensor hardware, as would be applicable for an alarm setpoint. The Analog Value object can be used without any requirement for command priority; however, at startup, the Analog Value present value properties in the BB2-7010 will all default to zero. If the BACnet client (typically a facility management system) is not quick enough to write setpoints to the BB2-7010, alarms will be cleared in the sensor the first time it reports in, and only restored at some later time when the client gets around to updating the setpoints. If you want the BB2-7010 to use known default alarm setpoint values at startup, use Analog Output objects for alarm setpoints, and enter the default alarm setting as the "Relinquish Default" value.

If an alarm setpoint object is given, it will be used, and will override any setpoint value entered on this page. If the setpoint object is left set to zero, then the setpoint value shown on this page will be used. All parameters on this page are stored in the XML configuration file when you click Save on the Config File page. (Forgetting to save the file will result in settings being lost the next time power is lost.) Whether a setpoint object or setpoint value is provided, in either case, the Alarm Time must be non-zero to enable the alarm.

The "alarm time" is the amount of time in sensor update periods (transmit periods) that the condition must exist before being reported as an alarm. Alarm time of zero is disabled (on this setup page). A zero will be transmitted as FF to the sensor, and all alarm time values offset by -1 when sent. This means alarm time of zero disables the alarm, alarm time of one enables the alarm with immediate reporting, and alarm time of two will delay the report by one sensor update period (shown as 300 seconds on the example above).

Alarms are not particularly useful if the alarm state is not reported. The means for reporting alarms states is via the status objects provided on the setup page. The most suitable object type is Binary Input, although any Input or Value object could be used. The alarm state value will always be either zero or one, and therefore Binary is a suitable type. Binary objects also have the option of associating user defined text strings with the active and inactive states. Changes in alarm state can be reported autonomously with BACnet COV subscriptions or SNMP traps. The alarm states can also be queried via Modbus.

16.3 Sensor Data Page

The screen illustrated below shows sensor data and additional diagnostic information. This page shows sensor data as received most recently. The data received will be displayed here regardless of whether the data has been assigned to any BACnet objects.

Babel Buster 2
BACNET-MODBUS
NETWORK GATEWAY
MODEL BB2-7010-06

CONTROL SOLUTIONS, INC.
MINNESOTA

Data Objects Modbus BACnet SNMP **System**

Setup Sensors

Sensor Data **Sensor Setup**

This page displays data most recently returned by WiFi sensors.

WiFi Sensor List Showing sensors from Refresh < Prev Next >

Sensor	Sensor S/N	Type	IP	Chan 1 Data	Chan 2 Data	Life	Tx Count	Time since Tx
1	E1A3D018	76	192:168:1:202	76.653847	75.774551	538d	2628	3.57m
2	E1A3D024	76	192:168:1:203	1341.000000	69.285606	963d	19031	8.34m
3	E2044005	29	192:168:1:204	2.087872	0.000000	289d	74319	2.67m
4		00	0:0:0:0	0.000000	0.000000	0d	0	---

The sensor type as reported by the sensor at the serial number shown will be displayed along with the IP address from which it was received. Scaled data is displayed, and this data should be echoed in the applicable BACnet object. The calculated remaining battery life based on data returned by the sensor is displayed. The total number of transmissions is indicated as well as time elapsed since the last transmission was received. Times are in seconds (s), minutes (m), hours (h) or days (d).



17. WiFi Sensor Setup - Veris Industries

The BB2-7010-07 is an enhancement to the standard BB2-7010-02 which adds recognition of Veris Industries WiFi sensors that transmit data to a UDP or TCP port which the user may configure. The sensor packets utilize the Veris data packet format. Refer to Veris Industries documentation for setup of the sensor itself. The BB2-7010-07 will make the Veris sensor data available as BACnet objects (and Modbus registers or SNMP OID's).

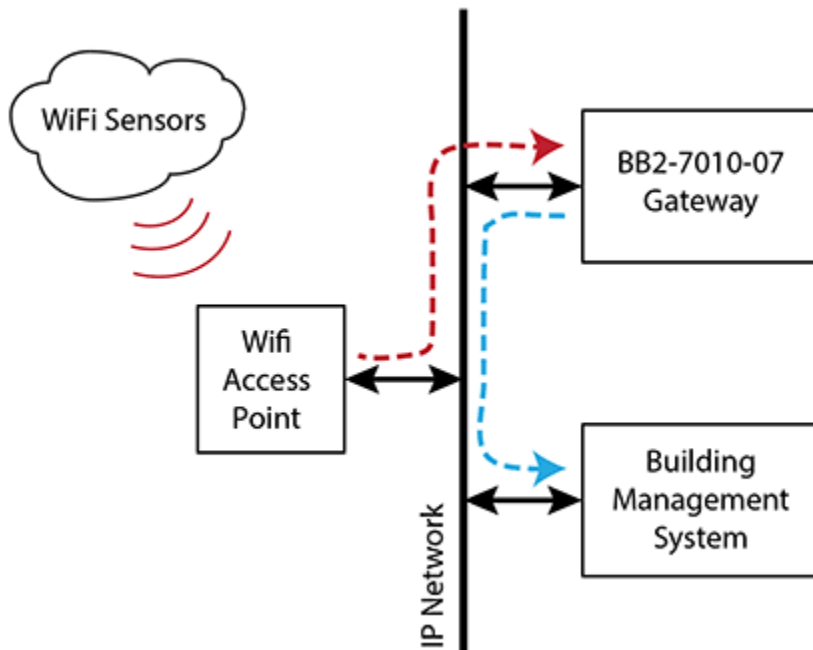

A standard generic WiFi access point is used to connect the WiFi sensors to the wired network. The access point should be placed where it has access to the wired network, but also where it will have good reception of the WiFi sensor signals. Typically, the BB2-7010-07 gateway will be located inside a control panel, but the WiFi access point will be located outside the control panel and potentially some distance from the panel.

17.1 Sensor Network Settings

The WiFi sensors need to initially be configured using the sensor configuration utility. One of the required settings is the IP address of the server to which the sensor should send data. That IP address will be the address of the BB2-7010-07 gateway which is set on the Local Host page shown here. If NAT routers are placed between the sensors and the gateway, then use IP addresses provided by the IT technician that set up the router.

Data Objects	Modbus	BACnet	SNMP	System
Setup	Sensors			
Config File	BACnet IP Port	BBMD	Local Host	User

This page allows you to change this device's IP address, and select whether double registers are swapped when returned to a remote client accessing this server.

IP Address	<input type="text" value="192.168.1.156"/>	192.168.1.156	<input type="button" value="- Refresh -"/>
Subnet Mask	<input type="text" value="255.255.255.0"/>	255.255.255.0	<input type="button" value="Change IP"/>
Gateway	<input type="text" value="192.168.1.1"/>	192.168.1.1	
MAC Address	00:40:9D:78:C1:ED		
HTTP Port	<input type="text" value="80"/> (default 80)		<input type="button" value="Set Port"/>
Uptime	1,11:45:57		
Sensor Port	<input type="text" value="6788"/> (default 6788)		<input type="button" value="Set Sensor Port"/>
UDP Port Status: 0	TCP Port Status:	0	
Packet CRC Error Count: 0	Bad Packet Count:	0	
Missed Packet Count: 0			

The sensors send data to UDP and TCP ports 6788 by default. To change that, go to the Network configuration page where the gateway's IP address is set, and select a different port if desired.

Port status is also shown on the network setup (Local Host) page. These should normally all be zero since they are error counts and error codes. Port status of zero means no error.

17.2 Sensor Configuration

The screen illustrated below is used to set up recognition of the WiFi sensor packets.

WiFi sensors that will be recognized by the system are entered here.

Showing 1 to 15 of 200 Update < Prev Next >

Sensor	Sensor MAC	Timeout (minutes)	Chan 1 Object #	Chan 2 Object #	Chan 3 Object #	Chan 4 Object #
1	74D850010001	2	AI 1	AI 2	AI 3	0
2	74D850010002	2	AI 4	AI 5	0	0
3	74D850010003	2	AI 6	AI 7	0	0
4	000000000000	0	0	0	0	0

Enter the 8-character hexadecimal MAC address of the sensor whose data is to be received. Select local BACnet objects where data from channels 1 through 4 of the sensor should be stored. BACnet objects should be either Analog Input or Analog Value. Do not use any other object type.

Enter a sensor timeout in minutes. If the BB2-7010-07 does not receive data from this sensor within this amount of time, the BACnet object's reliability property will be set to the non-zero error code indicating timeout. In addition, the optional timeout fault value will be placed into the object's present value property if selected on the extended setup page.

To access additional setup parameters, click on the sensor number in the first column. This will take you to the extended setup page illustrated below.

The screenshot shows a web-based configuration interface for a WiFi sensor. At the top, there are navigation tabs for 'Data Objects', 'Modbus', 'BACnet', 'SNMP', and 'System'. Below these are sub-tabs for 'Setup' and 'Sensors'. The 'Sensor Data' sub-tab is active, showing 'Sensor Setup' for 'Sensor # 1'. A text box indicates that WiFi sensors are entered here. The interface includes an 'Update' button and navigation buttons '< Prev' and 'Next >'. The configuration fields are as follows:

Field	Value
Device	MAC Address 74D850010001
Timeout	2
Channel 1 Data	Data Object AI 1
Scale	1.80000
Timeout Fault	<input type="checkbox"/> 0.00000
Offset	32.00000
Channel 2 Data	Data Object AI 2
Scale	0.00000
Timeout Fault	<input type="checkbox"/> 0.00000
Offset	0.00000
Channel 3 Data	Data Object AI 3
Scale	0.00000
Timeout Fault	<input type="checkbox"/> 0.00000
Offset	0.00000
Channel 4 Data	Data Object 0
Scale	0.00000
Timeout Fault	<input type="checkbox"/> 0.00000
Offset	0.00000
Battery Voltage	Data Object 0
RSSI	Data Object 0

The same sensor setup information found on the tabular list is also available here, in addition to user scaling and fault values. The example shown here for AI 1 will display temperatures in Fahrenheit when actual data received was Celsius temperature.

Analog Input is the most suitable BACnet object for recording data values read by sensors. Analog Value would also be an appropriate choice, although with no particular advantage over Analog Input. Analog Output is not a suitable choice for sensor values since these objects are meant to be written to BB2-7010, not read from. Analog Input is typically a sensor object, while Analog Output is typically an actuator object. Any data object set to zero will not have that data transferred to any BACnet object.

Timeout fault is optional. If the box is checked, and a value is entered in the adjacent window, that value will be placed into the data channel's object when the sensor is in fault, i.e., when the BB2-7010 has not received data from this sensor within the timeout window specified.

Battery voltage and signal strength readings reported by the sensor can optionally be provided as BACnet objects if provided. Analog Input or Analog Value object types are most suitable here.

17.3 Sensor Data Page

The screen illustrated below shows sensor data as received most recently. The data received will be displayed here regardless of whether the data has been assigned to any BACnet objects. This page also displays time elapsed since the last transmission was received. Times are in seconds (s), minutes (m), hours (h) or days (d).



This page displays data most recently returned by WiFi sensors.

WiFi Sensor List Showing sensors from

Sensor	Sensor MAC	Type	Chan 1 Data	Chan 2 Data	Chan 3 Data	Chan 4 Data	Time since Tx
<u>1</u>	74D850010001	0A,07	71.599998	40.000000	400.000000	0.000000	7.2s
<u>2</u>	74D850010002	07,03	71.599998	40.000000	0.000000	0.000000	6.2s
<u>3</u>	74D850010003	03,08	59.000000	0.000000	0.000000	0.000000	5.2s
<u>4</u>	000000000000	00,00	0.000000	0.000000	0.000000	0.000000	---

Click on the sensor number in the first column in the Sensor Data page to access additional sensor information illustrated below. This page reflects whatever information was transmitted by the respective sensor.

WiFi sensor statistical data is displayed on this page.

Sensor #

MAC Address: 74D850010001	Type,Subtype: 0A,07
Number of Sensors: 4	Software Version: 2.01
Uptime: 0	
Listen mode times: 224	Reconnect times: 0
Packets sent: 140	
Battery Voltage: 0.00	RSSI: -50.00
Tag error: 0	Conversion error: 0
Sensor type error: 0	



18. WiFi Sensor Setup - Functional Devices RIB

The BB2-7010-08 is an enhancement to the standard BB2-7010-02 which adds support for Functional Devices WiFi RIB sensors and relays. The data packets utilize the HTML/XML data format documented in the RIB user manual. Refer to Functional Devices documentation for setup of the sensor/relay itself. The BB2-7010-08 will make the RIB sensor data available as BACnet objects (and Modbus registers or SNMP OID's). The BB2-7010-08 will also allow control of the RIB relay from BACnet, Modbus, or SNMP networks.

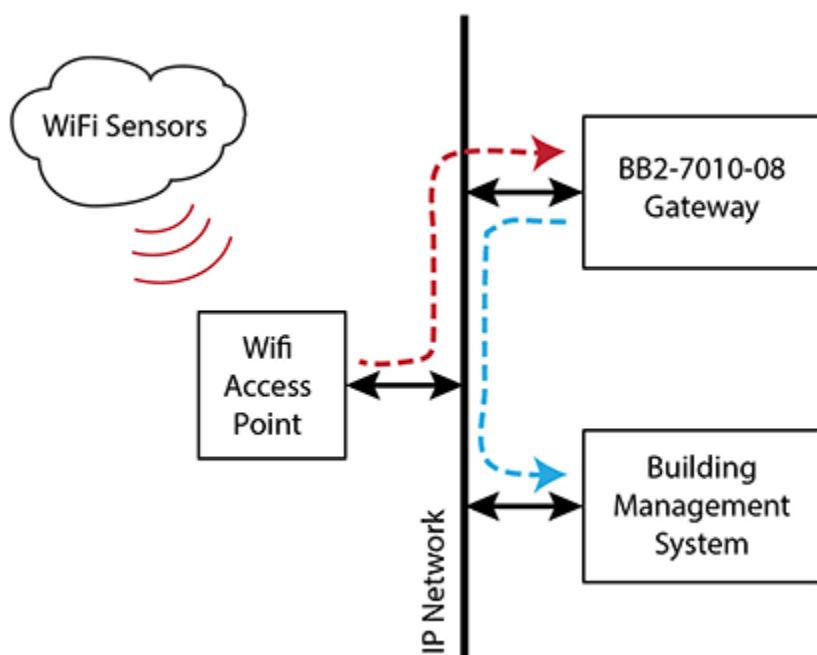

A standard generic WiFi access point is used to connect the WiFi sensors to the wired network. The access point should be placed where it has access to the wired network, but also where it will have good reception of the WiFi sensor signals. Typically, the BB2-7010-08 gateway will be located inside a control panel, but the WiFi access point will be located outside the control panel and potentially some distance from the panel.

18.1 Sensor Network Settings

The WiFi sensors need to initially be configured using the sensor configuration utility. One of the required settings is the IP address of the server to which the sensor should send data. That IP address will be the address of the BB2-7010-08 gateway which is set on the Local Host page shown here. If NAT routers are placed between the sensors and the gateway, then use IP addresses provided by the IT technician that set up the router.

This page allows you to change this device's IP address, and select whether double registers are swapped when returned to a remote client accessing this server.

IP Address 192.168.1.33

Subnet Mask 255.255.255.0

Gateway 192.168.1.1

MAC Address 00:40:9D:89:66:F6

HTTP Port (default 80)

Uptime 0,01:33:50

The sensors send data to UDP port 6767 by default. To change that, go to the Network configuration page where the gateway's IP address is set, and select a different UDP port if desired.

18.2 Sensor Configuration

The screen illustrated below is used to set up recognition of the WiFi sensor packets.

WiFi sensors that will be recognized by the system are entered here.

Showing to 10 of 10

Sensor	Sensor IP Addr	Poll Time (seconds)	DO 1 Object #	DI 1 Object #	UI 1 Object #	UI 2 Object #
1	<input type="text" value="192.168.1.206"/>	<input type="text" value="10"/>	<input type="text" value="BO 1"/>	<input type="text" value="BI 1"/>	<input type="text" value="AI 1"/>	<input type="text" value="AI 2"/>
2	<input type="text" value="192.168.1.207"/>	<input type="text" value="10"/>	<input type="text" value="BO 2"/>	<input type="text" value="BI 2"/>	<input type="text" value="AI 3"/>	<input type="text" value="AI 4"/>
3	<input type="text" value="0.0.0.0"/>	<input type="text" value="0"/>	<input type="text" value="0"/>	<input type="text" value="0"/>	<input type="text" value="0"/>	<input type="text" value="0"/>

Enter the IP address of the sensor that is to be queried. Select local BACnet objects to be associated with the RIB inputs and output. BACnet object type should be Binary Output for DO 1 (the relay). BACnet object type should be Binary Input for DI 1 (discrete input). BACnet object types can be Analog Input or Analog Value for the UI inputs if configured for analog values. BACnet object types can be Binary Input or Binary Value if UI inputs are configured as state inputs instead.

Enter a sensor poll time in seconds. This is the frequency at which the BB2-7010-08 will attempt to query the RIB. If the BB2-7010-08 is unable to connect to the RIB, the BACnet object's reliability property will be set to the non-zero error code indicating no connection. In addition, the optional connect fault value will be placed into the object's present value property if selected on the extended setup page.

To access additional setup parameters, click on the sensor number in the first column. This will take you to the extended setup page illustrated below.

WiFi sensors that will be recognized by the system are entered here.

Sensor #

Device	IP Address	<input type="text" value="192.168.1.206"/>	Poll Time (sec)	<input type="text" value="10"/>
	User Name	<input type="text"/>		
	Password	<input type="text"/>		
DO 1 Data	Data Object	<input type="text" value="BO 1"/>		
DI 1 Data	Data Object	<input type="text" value="BI 1"/>	Link Object	<input type="text" value="BO 2"/>
	Connect Fault	<input type="checkbox"/> <input type="text" value="0.00000"/>		
UI 1 Data	Data Object	<input type="text" value="AI 1"/>	Scale	<input type="text" value="0.00000"/>
	Connect Fault	<input type="checkbox"/> <input type="text" value="0.00000"/>	Offset	<input type="text" value="0.00000"/>
UI 2 Data	Data Object	<input type="text" value="AI 2"/>	Scale	<input type="text" value="0.00000"/>
	Connect Fault	<input type="checkbox"/> <input type="text" value="0.00000"/>	Offset	<input type="text" value="0.00000"/>
Signal Strength	Data Object	<input type="text" value="0"/>		

The same sensor setup information found on the tabular list is also available here, in addition to user scaling and fault values. Scale factors may be optionally applied to the analog sensor values. Data received from the sensor will be multiplied by the scale factor, then added to offset, before being placed into BACnet data objects.

User name and password should only be entered here if the RIB has been configured to use a password. If the RIB has been configured to require a password and it is not entered here, then the connection will fail.

The Link Object for the DI input is optional. The RIB allows the DI to be "bound" to the DO within the RIB. The Link Object here allows a DI from one RIB to be "bound" to the DO in a different RIB with the binding provided by the BB2-7010-08. Response time will be the poll time, meaning a change on a DI in one RIB will be propagated to the the linked DO in a different RIB the next time that sensor is polled. The Link Object should be a Binary Output object, and should be the same BO assigned to the DO in a different RIB. (Note: If the DO is bound to the DI via configuration within the same RIB, do not enter that binding here as the RIB will manage the binding internally in that case.)

Connect fault is optional. If the box is checked, and a value is entered in the adjacent window, that value will be placed into the data channel's object when the sensor is in fault, i.e., when the BB2-7010 was not able to connect to this sensor. If connection is successful on the next try, then the data received will be

placed into the BACnet data object and the reliability code will be cleared to zero.

Signal strength readings reported by the sensor can optionally be provided as a BACnet object if provided. Analog Input or Analog Value object types are most suitable here.

18.3 Sensor Data Page

The screen illustrated below shows sensor data as received most recently. The data received will be displayed here regardless of whether the data has been assigned to any BACnet objects. This page also displays time elapsed since the last transmission was received. Times are in seconds (s), minutes (m), hours (h) or days (d).

This page displays data most recently returned by WiFi sensors.

WiFi Sensor List Showing sensors from

Sensor	Sensor IP Addr	DO 1 State	DI 1 State	UI 1 Data	UI 2 Data	Time since update
<u>1</u>	192.168.1.206	Active	Inactive	2.460000	4.730000	6.3s
<u>2</u>	192.168.1.207	Inactive	Active	1.120000	3.310000	5.9s
<u>3</u>	0.0.0.0	---	---	---	---	---
<u>4</u>	0.0.0.0	---	---	---	---	---
<u>5</u>	0.0.0.0	---	---	---	---	---
<u>6</u>	0.0.0.0	---	---	---	---	---
<u>7</u>	0.0.0.0	---	---	---	---	---
<u>8</u>	0.0.0.0	---	---	---	---	---
<u>9</u>	0.0.0.0	---	---	---	---	---
<u>10</u>	0.0.0.0	---	---	---	---	---

[Sensor packet diagnostic page](#)

Click on the sensor number in the first column in the Sensor Data page to access additional sensor information illustrated below. This page reflects whatever information was transmitted by the respective sensor. The Reset button clears the error indication and may be used to see if the next retry returns the same error. The error code will automatically clear to zero (upon refresh of the page) if the connection was successful.

The screenshot displays a web interface with a top navigation bar containing tabs for Data Objects, Modbus, BACnet, SNMP, and System. Below this is a sub-navigation bar with Setup and Sensors tabs. The main content area is titled "Sensor Data" and "Sensor Setup". A message states: "WiFi sensor additional information is displayed on this page." Below this is a form with a "Sensor #" input field containing the number "1", and buttons for "Update", "< Prev", and "Next >". A "Reset" button is located at the bottom of the information display area.

WiFi sensor additional information is displayed on this page.

Sensor #

IP Address: 192.168.1.206
Device Version: v4.0.9.1.0 WIUI Software Version: 12556
Device Name: RIB BOX 1
Device Location: Lab
SSID: WiFiSensor
Signal Strength: 0
Connection error: 0/0

18.4 Sensor Diagnostic Page

Click on the sensor diagnostic page link at the bottom of the sensor data page to access the page illustrated below. Enter a sensor number and click Update to select a sensor. Thereafter, each packet received in response to query will be displayed when the page is refreshed. This page is provided simply for diagnostic use.

Sensor #

WiFi Sensor Packet Log for Sensor #1

```
<relayState>ON</relayState>
<lastCommand>ON</lastCommand>
<digitalInputState>OPEN</digitalInputState>
<ui1State>0-5V</ui1State>
<ui1Value> 0.00 V</ui1Value>
<di1Value>OPEN</di1Value>
<ui2State>0-5V</ui2State>
<ui2Value> 0.00 V</ui2Value>
<di2Value>OPEN</di2Value>
<powerOnState>OFF</powerOnState>
<bindingState>UNBOUND</bindingState>
<deviceHostName>RIB BOX 1 </deviceHostName>
<deviceLocation>Lab</deviceLocation>
<deviceVersion>v4.0.9.1.0 WIUI</deviceVersion>
<bss>
<valid>0</valid>
<name>0</name>
<privacy>0</privacy>
<wlan>0</wlan>
<strength>0</strength>
</bss>
<scan>0</scan>
<ver>12556</ver>
<count>0</count>
<ssid>WiFiSensor</ssid>
```

Appendix A Hardware Details

A.1 Wiring

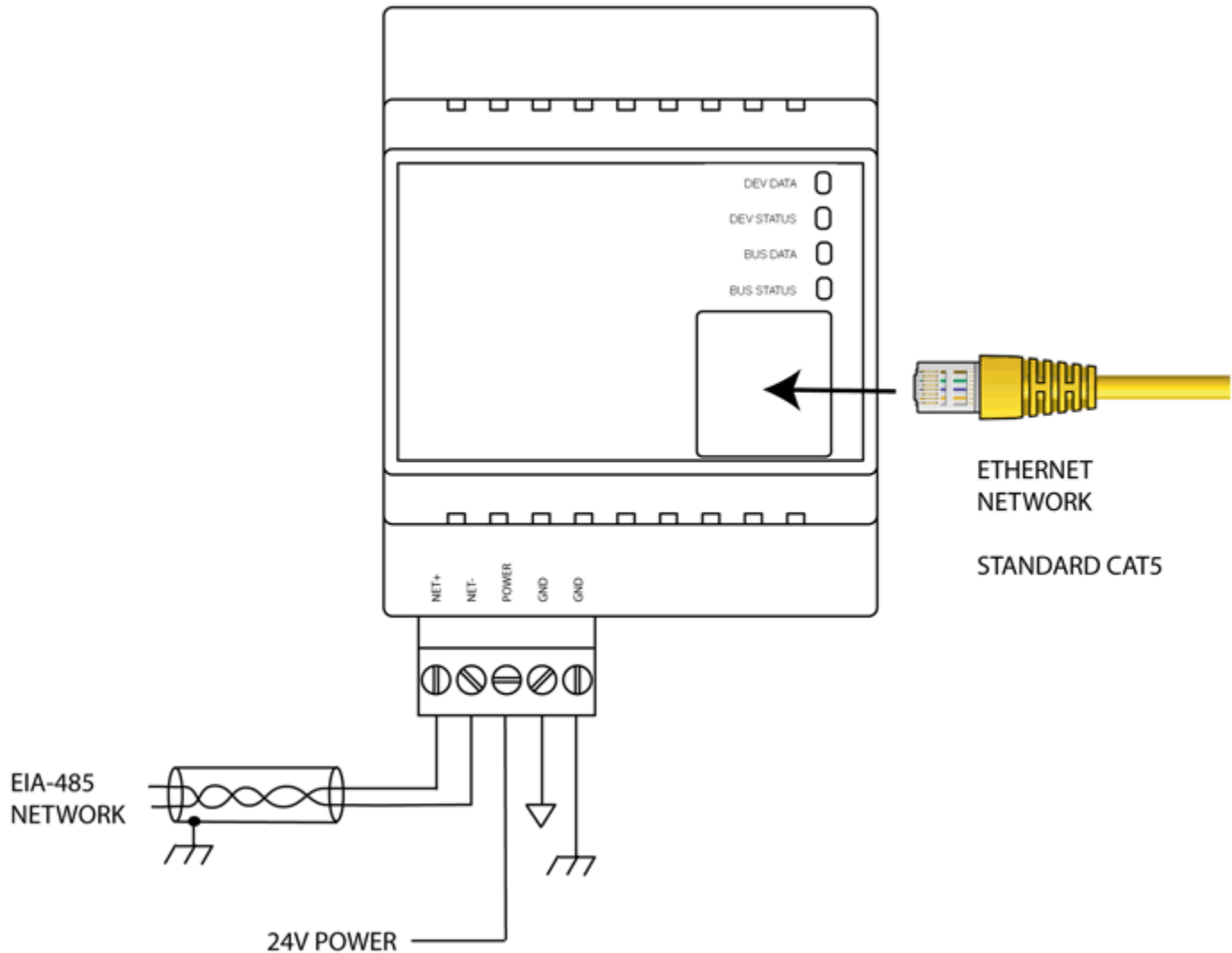

Wire the BB2-7010 as illustrated above. Follow all conventional standards for wiring of EIA-485 networks when connecting the Modbus RTU EIA-485 (RS485) network. This includes use and termination of shield, termination of the network, and grounding.

IMPORTANT: Although EIA-485 (RS485) is thought of as a 2-wire network, you **MUST** include a third conductor connected to GND or common at each device so that all devices are operating at close to the same ground potential. Proper grounding of equipment should ensure proper operation without the third conductor; however, proper grounding often cannot be relied upon. If large common mode voltages are present, you may even need to insert optically isolated repeaters between EIA-485 devices.

Use standard CAT5 cables for Ethernet connections. Use control wire as applicable for local electrical codes for connecting the 24V (AC or DC) power supply.

Note that in addition to connecting power supply common to a GND terminal, you must also connect a GND terminal to earth ground in order to ensure proper ESD protection.

BB2-7010-xx-232: The standard BB2-7010 Modbus RTU port uses RS-485. The RS-232 version replaces the RS-485 transceiver with an RS-232 transceiver. The NET+/NET- terminals are replaced by TXD and RXD on the RS-232 version. TXD is data out from the BB2-7010, and RXD is data in to the gateway. Hardware handshake is not supported.

A.2 Front Panel LED Indicators

Power-up LED behavior: All LEDs on front panel will turn on yellow or red for half a second, then all will turn on green for half a second. Then they will proceed to indicate as normally defined for the indicators.

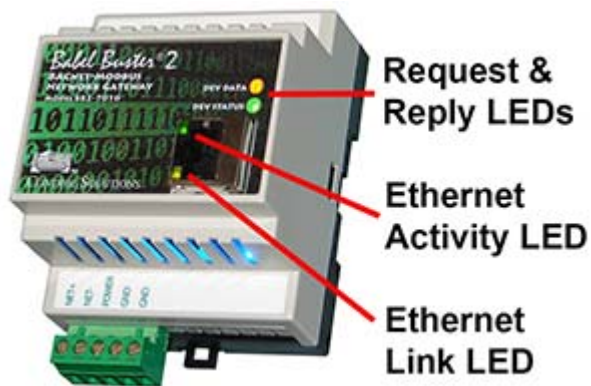

The LED indicators behave as follows. Normally the reply/request LEDs reflect Modbus RTU activity. If the gateway is being used only for Modbus TCP (as SNMP gateway), then the same LEDs reflect TCP behavior instead. The LEDs do not attempt to reflect both RTU and TCP activity since that would get confusing. If both RTU and TCP are used, the request/reply LEDs reflect RTU traffic while the Ethernet activity LED will indicate TCP traffic. To see TCP errors, one needs to look at the Errors page in the web UI.

DEV DATA	Flashes yellow each time a request is sent when operating as Modbus Master, or each time a request is received when operating as Modbus Slave.
DEV STATUS	Operating as Modbus Master, flashes green each time a good response is received, or red when an error code is received, the request times out, or there is a flaw in the response such as CRC error.

Operating as Modbus Slave, flashes green each time a good response is sent, or red if an exception code is sent (meaning the received request resulted in an error).

A.3 RS-485 Line Termination & Bias

Enable line termination only when this device is placed at the end of the network. Termination should only be enabled at two points on the network, and these two points must be specifically the end points.

Enable line bias when needed. Line bias should only be enabled at one point on the network, and does not have to be the end point. Line bias holds the line in a known neutral state when no devices are transmitting. Without bias, the transition from offline to online by a transmitter can look like a false start bit and cause loss of communication.

The line conditioning options are enabled when the respective shunt is moved to the position indicated by the white block next to the 3-pin header. Putting the shunt on the opposite 2 pins disables the option, and is simply a place to store the shunt.

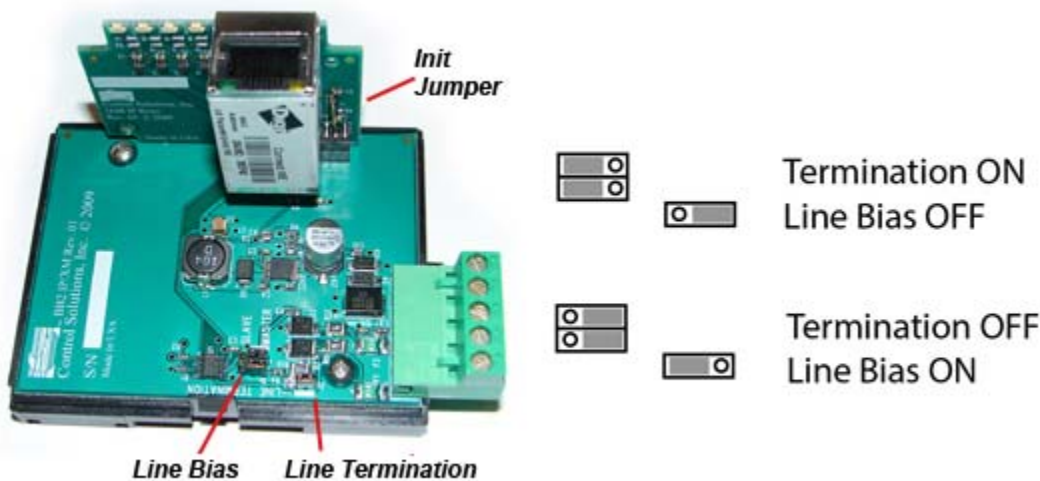

The "Init" jumper on the server module should only be used when advised by tech support. Installing this jumper prior to power-up causes the server to go into firmware update mode.