

<b>Model</b>	<b>HWP 36RKSYS</b>
Item No. (Standard/Opposite Hand)	510-036-001 / 510-036-011
Cooling capacity (net) to AS/NZS 3823 T1	3.4 kW
Heating capacity H1	3.7 kW
Electrical input - cooling	0.91 kW
Electrical input - heating	0.90 kW
EER / AEER (cooling)	3.69 / 3.67
COP / ACOP (heating)	4.08 / 4.04
Unit Controller	UC8
Refrigerant	R410A
Refrigerant charge	870 g
Compressor type	rotary
Water connections	1/2" male BSP
Nominal EWT on cooling	30°C
Nominal EWT on heating	21°C
Nominal Water Flow @ EWT – LWT = 5k	0.22 l/s
Entering system pressure drop @ nominal flow	27.6 kPa (4 psi)
Min. water temp. Heat cycle at nominal flow	10°C
Min. water temp. Cool cycle at nominal flow	15°C
Min. water temp. Cool cycle with water regulating valve	5°C
Max. EWT Heat cycle at nominal flow	30°C
Max. EWT Cool cycle at nominal flow	50°C
Min. water flow @ nominal EWT	0.06 l/s
Max. water pressure – excluding hoses	3200 kPa (464 psi)
Power supply	1 ph. 230V ac 50Hz
Compressor run amps at rating cond.	3.6 A
Compressor run capacitor	30 $\mu$ fd
Indoor fan motor size	230 W (EC)
Indoor fan motor (1ph.) - full load	1.3 A
Control circuit breaker (internal)	10 A
Running amps (total system)	4.0 A
Max. running amps (total system)	6.1 A
Net weight	75 kg

Accessories:

Spring mounts	supplied
Water hoses 600mm long, rated 1720 kPa (250psi)	1/2" female BSP, supplied
Replacement filter - rated EU2/G2	119-000-098 513x265x13
Condensate lift-pump	507-003-009

Optional:

SAT-3 Room temperature controller	201-000-146
TZT-100 Room temperature controller	201-000-350

Refer to temperzone for other options, eg remote sensors

# DIMENSIONS (mm)

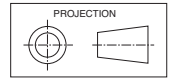

Not to Scale

## HWP 36RKSYS Standard

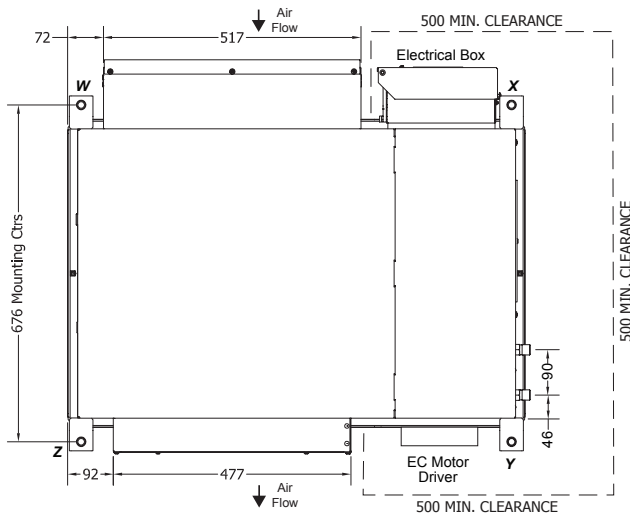

POINT LOADS (kg)			
W	X	Y	Z
19	21	26	9

**Note:** Fan motor can be accessed from panel above, below or sides; no more than two panels at once.

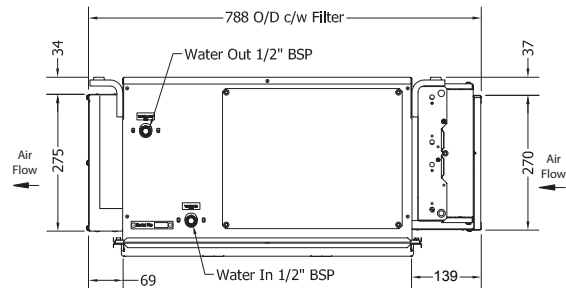
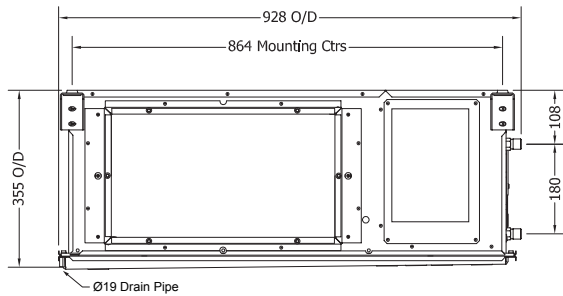

## HWP 36RKSYS Opposite Hand

POINT LOADS (kg)			
W	X	Y	Z
26	9	19	21

**Note:** Fan motor can be accessed from panel above, below or sides; no more than two panels at once.

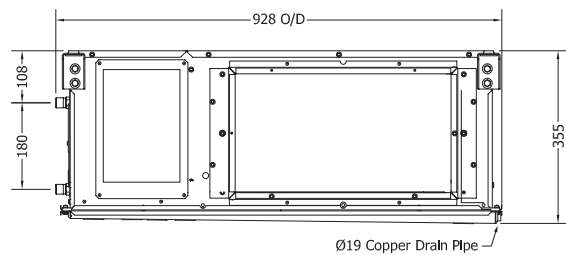
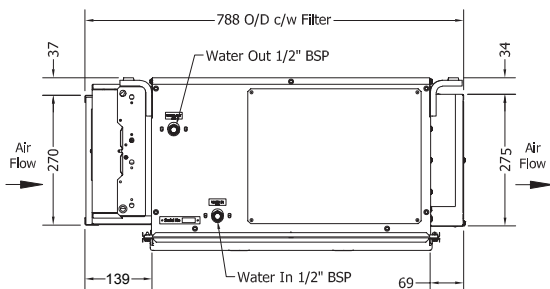
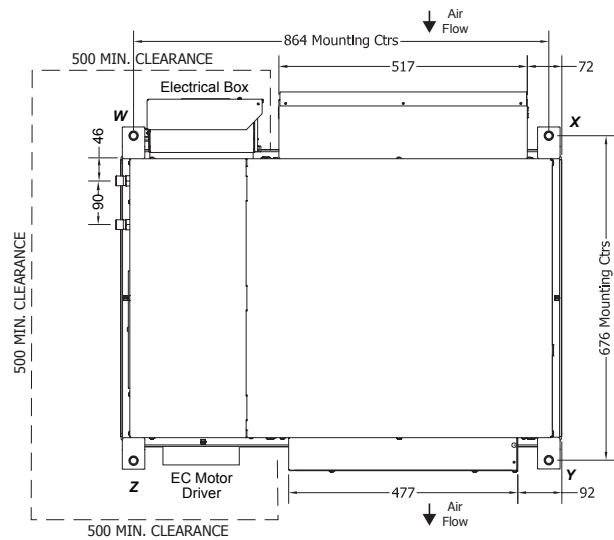

### NOTE

Specifications are subject to change without notice due to the manufacturer's ongoing research and development programme.



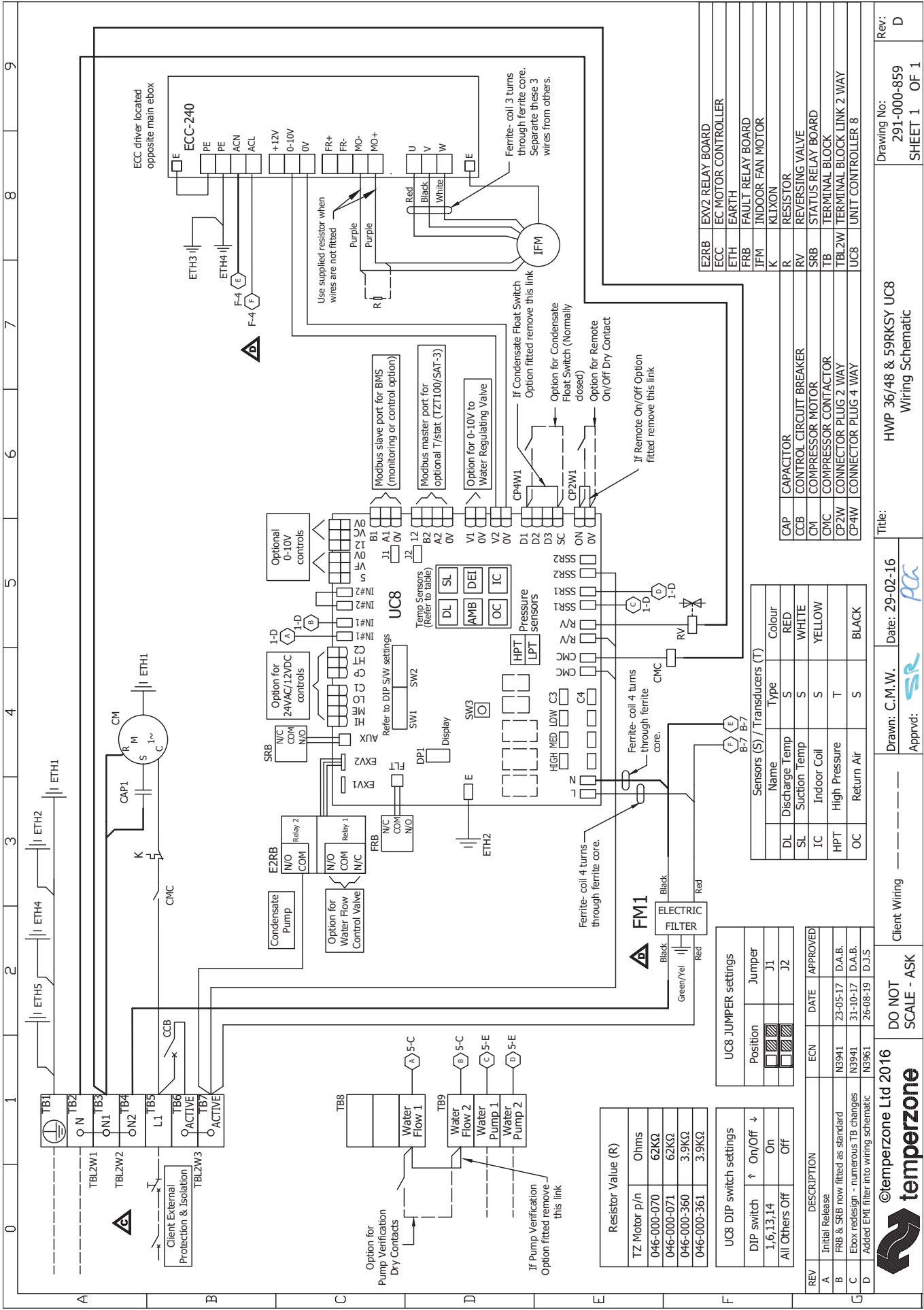

E2RB	EXV2 RELAY BOARD
ECC	EC MOTOR CONTROLLER
ETH	EARTH
FRB	FAULT RELAY BOARD
IFM	INDOOR FAN MOTOR
K	KLIXON
R	RESISTOR
RV	REVERSING VALVE
SRB	STATUS RELAY BOARD
TB	TERMINAL BLOCK
TBL2W	TERMINAL BLOCK LINK 2 WAY
UC8	UNIT CONTROLLER 8

CAP	CAPACITOR
CCB	CONTROL CIRCUIT BREAKER
CM	COMPRESSOR MOTOR
CMC	COMPRESSOR CONTACTOR
CP2W	CONNECTOR PLUG 2 WAY
CP4W	CONNECTOR PLUG 4 WAY

Sensors (S) / Transducers (T)		
Name	Type	Colour
DL	Discharge Temp	RED
SL	Suction Temp	WHITE
IC	Indoor Coil	YELLOW
HPT	High Pressure	T
OC	Return Air	BLACK

UC8 JUMPER settings		
Position	Jumper	
<input type="checkbox"/>	J1	
<input type="checkbox"/>	J2	

UC8 DIP switch settings		
DIP switch	On/Off	
1,6,13,14	On	
All Others	Off	

REV	DESCRIPTION	ECN	DATE	APPROVED
A	Initial Release			
B	FRB & SRB now fitted as standard	N3941	23-05-17	D.A.B.
C	Ebox redesign - numerous TB changes	N3941	31-10-17	D.A.B.
D	Added EMI Filter into wiring schematic	N3961	26-08-19	D.J.S

**temperzone**  
 ©temperzone Ltd 2016  
 Client Wiring  
 DO NOT SCALE - ASK  
 Drawing No: HWP 36/48 & 59RKSX UC8  
 Title: Wiring Schematic  
 Date: 29-02-16  
 Drawn: C.M.W.  
 Approved: *FC*  
 Rev: D  
 SHEET 1 OF 1



<b>Model</b>	<b>HWP 36CEKSY</b>
Item No. (Standard/Opposite Hand)	510-036-102 / 510-036-112
Cooling capacity (net) to AS/NZS 3823 T1	3.4 kW
Heating capacity - Electric heat	2.0 kW
Electrical input - cooling	0.9 kW
Electrical input - heating	2.1 kW
EER / AEER (cooling)	3.69 / 3.67
Unit Controller	UC8
Refrigerant	R410A
Refrigerant charge	780 g
Compressor type	rotary
Water connections	1/2" male BSP
Nominal EWT on cooling	30°C
Nominal EAT on cooling	27°C db, 19°C wb
Nominal Water Flow @ EWT – LWT = 5k	0.22 l/s
Entering system pressure drop @ nominal flow & EAT	27.6 kPa (4 psi)
Min. water temp. Cool cycle at nominal flow	15°C
Min. water temp. Cool cycle with water regulating valve	5°C
Max. EWT Cool cycle at nominal flow & EAT	50°C
Min. water flow @ nominal EWT & EAT	0.06 l/s
Max. water pressure – excluding hoses	3200 kPa (464 psi)
Power supply	1 ph. 230V ac 50Hz
Compressor run amps at rating cond.	3.6 A
Compressor run capacitor	30 µfd
Indoor fan motor size	230 W (EC)
Indoor fan motor (1ph.) - full load	1.3 A
Control circuit breaker (internal)	10 A
Running amps (total system)	9.1 A
Max. running amps (total system)	10.0 A
Net weight	75 kg

Accessories:

Spring mounts	supplied
Water hoses 600mm long, rated 1720 kPa (250psi)	1/2" female BSP, supplied
Replacement filter - rated EU2/G2	119-000-098 513x265x13
Condensate lift-pump	507-003-009

Optional:

SAT-3 Room temperature controller	201-000-146
TZT-100 Room temperature controller	201-000-350

Refer to temperzone for other options, eg remote sensors

# DIMENSIONS (mm)

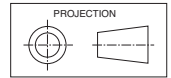

Not to Scale

## HWP 36CEKSY Standard

Right handed model shown here

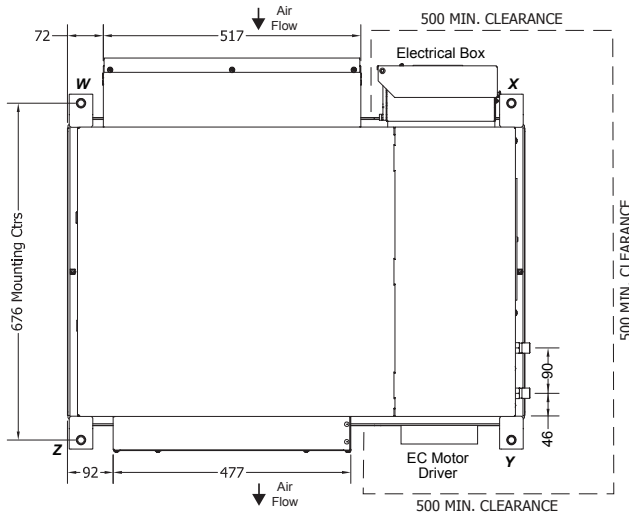

POINT LOADS (kg)			
W	X	Y	Z
19	21	26	9

**Note:** Fan motor can be accessed from panel above, below or sides; no more than two panels at once.

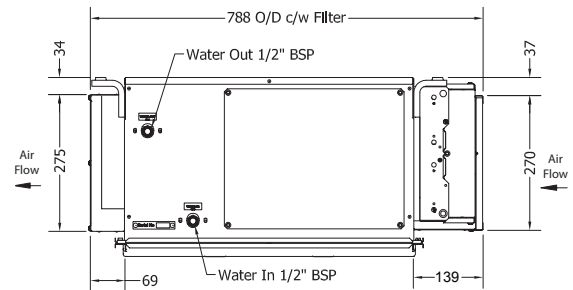
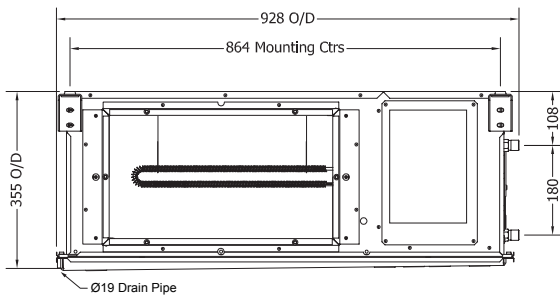

## HWP 36CEKSY Opposite Hand

POINT LOADS (kg)			
W	X	Y	Z
26	9	19	21

**Note:** Fan motor can be accessed from panel above, below or sides; no more than two panels at once.

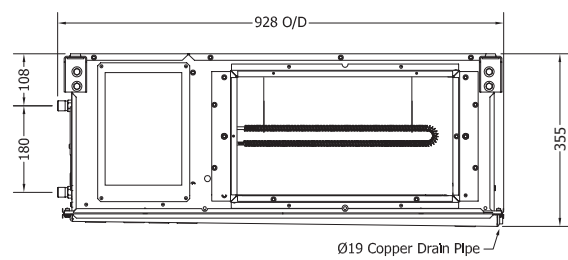
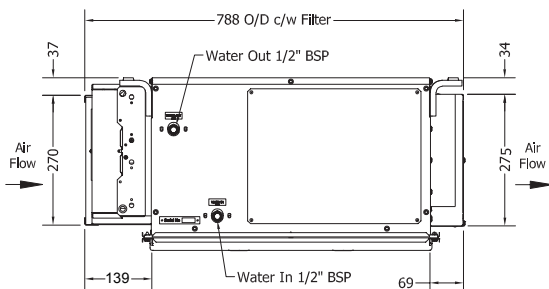
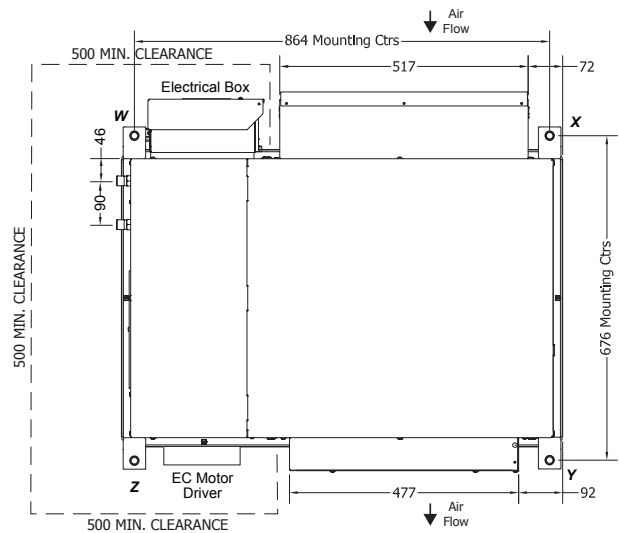

### NOTE

Specifications are subject to change without notice due to the manufacturer's ongoing research and development programme.



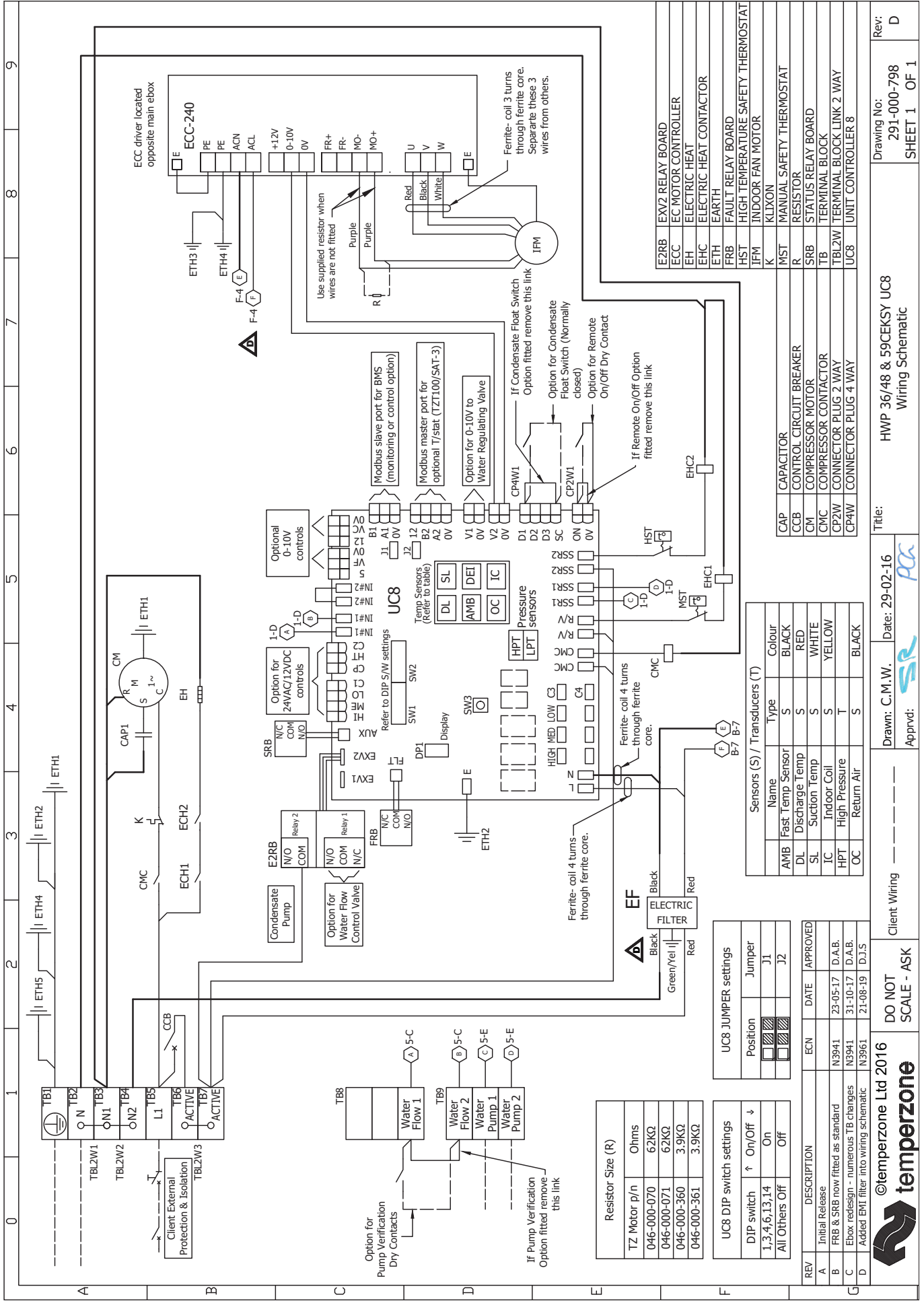

E2RB	EXV2 RELAY BOARD
ECC	EC MOTOR CONTROLLER
EH	ELECTRIC HEAT
EHC	ELECTRIC HEAT CONTACTOR
ETH	EARTH
FRB	FAULT RELAY BOARD
IFM	HIGH TEMPERATURE SAFETY THERMOSTAT
K	KLIXON
MST	MANUAL SAFETY THERMOSTAT
R	RESISTOR
SRB	STATUS RELAY BOARD
TB	TERMINAL BLOCK
TBL2W	TERMINAL BLOCK LINK 2 WAY
UC8	UNIT CONTROLLER 8

Sensors (S) / Transducers (T)		
Name	Type	Colour
AMB	Fast Temp Sensor	BLACK
DL	Discharge Temp	RED
SL	Suction Temp	WHITE
IC	Indoor Coil	YELLOW
HPT	High Pressure	
OC	Return Air	BLACK

Resistor Size (R)	
TZ Motor p/n	Ohms
046-000-070	62KΩ
046-000-071	62KΩ
046-000-360	3.9KΩ
046-000-361	3.9KΩ

UC8 DIP switch settings	
DIP switch	On/Off
1,3,4,6,13,14	On
All Others	Off

UC8 JUMPER settings	
Position	Jumper
1	J1
2	J2

REV	DESCRIPTION	ECN	DATE	APPROVED
A	Initial Release			
B	FRB & SRB now fitted as standard	N3941	23-05-17	D.A.B.
C	Ebox redesign - numerous TB changes	N3941	31-10-17	D.A.B.
D	Added EMT filter into wiring schematic	N3961	21-08-19	D.J.S

©temperzone Ltd 2016

DO NOT SCALE - ASK

Client Wiring

Drawn: C.M.W. Date: 29-02-16

Approved:

Title: HWP 36/48 & 59CEKSY UC8 Wiring Schematic

Drawing No: 291-000-798 SHEET 1 OF 1

Rev: D



