

# SPECIFICATIONS



<b>Air Handling Unit</b> (345-540-XYZ / 345-545-000) <sup>1</sup>	<b>MT 540</b>	
Nominal Air Volume <sup>2</sup>	15 000 l/s	
Nominal Cooling Capacity <sup>3</sup>	4 row	370 kW
	6 row	35 kW
	8 row	465 kW
Nominal Heating Capacity <sup>4</sup>	1 row	305 kW
	2 row	519 kW
Fan type	EC plug (x4)	
Fan motor size (3ph.)	3500 W / 630 mm dia.	
Unit Max. running amps (total)	22.8 A /ph.	
Protection Rating	IP4X	
Power supply <sup>5</sup>	3 ph. 400 V ac 50 Hz + N + E	
RCD type recommended	type A, 30 m A, 3 pole	
Net weight – fan coil section	1081 – 1548 kg <sup>6</sup>	
Net weight – plenum section – bare	426 kg	
Net weight – plenum section – damper mix	565 kg	
Shipping weight – fan coil section	1198 – 1664 kg <sup>6</sup>	
Shipping weight – plenum section – bare	526 kg	
Shipping weight – plenum section – damper mix	665 kg	

**Accessories:**

Filter - rated EU4/G4 disposable	019-000-158 594 x 594 x 44 (x18)
Filter - rated EU4/G4 washable	019-400-140 594 x 594 x 46 (x18)
Filter - rated F7 bag type	019-400-153 592 x 592 x 600 (x18)
Filter - rated F9 cartridge type	019-400-160 592 x 592 x 292 (x18)

**Optional:**

Chilled water coil 1/2"	4 / 6 / 8 row
Hot water coil 1/2"	1 / 2 row

Refer to temperzone for other options, eg remote sensors

<sup>1</sup> X = cooling coil rows, Y = heating coil rows and Z = handing. (Fan Coil Section / Plenum Section {bare})

<sup>2</sup> Based on 2.5 m/s coil face velocity

<sup>3</sup> Cooling at nominal air flow, EAT 27 °C db / 19 °C wb, EWT 6°C, LWT 13°C.

<sup>4</sup> Heating at nominal air flow, EAT 15 °C, EWT 80°C, LWT 60°C.

<sup>5</sup> Voltage range: 380–440V

<sup>6</sup> Depending on coil configuration; refer table page 2

# DIMENSIONS (mm)

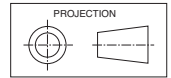

## MT 540 Complete Air Handling Unit

Not to Scale

Pipe Connections  
1/2" male BSP

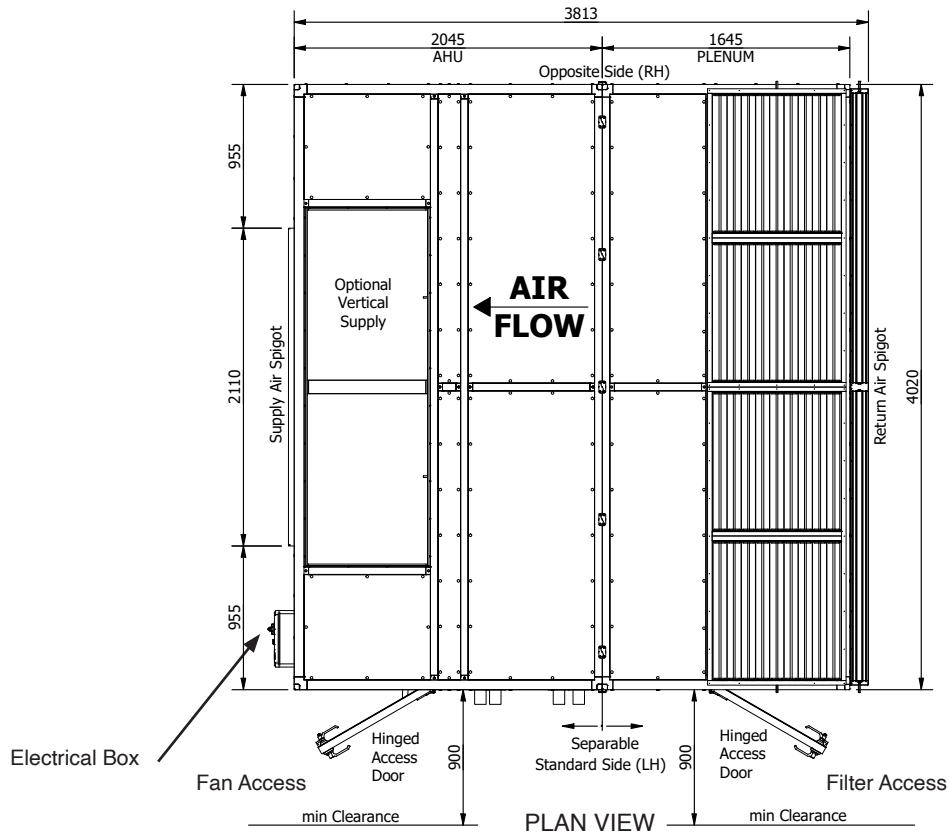

## MT 540 Fan Coil Section

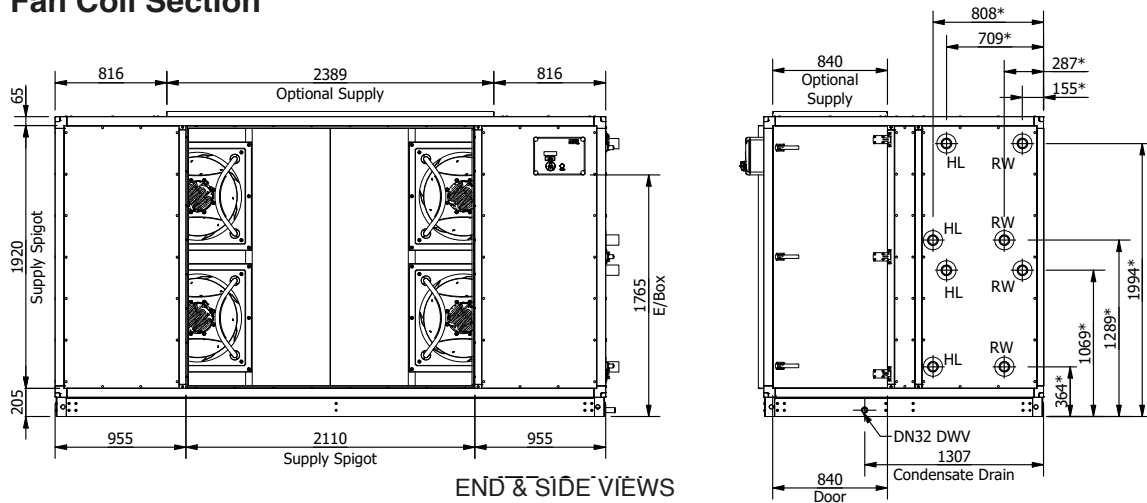

## MT 540 Plenum Section

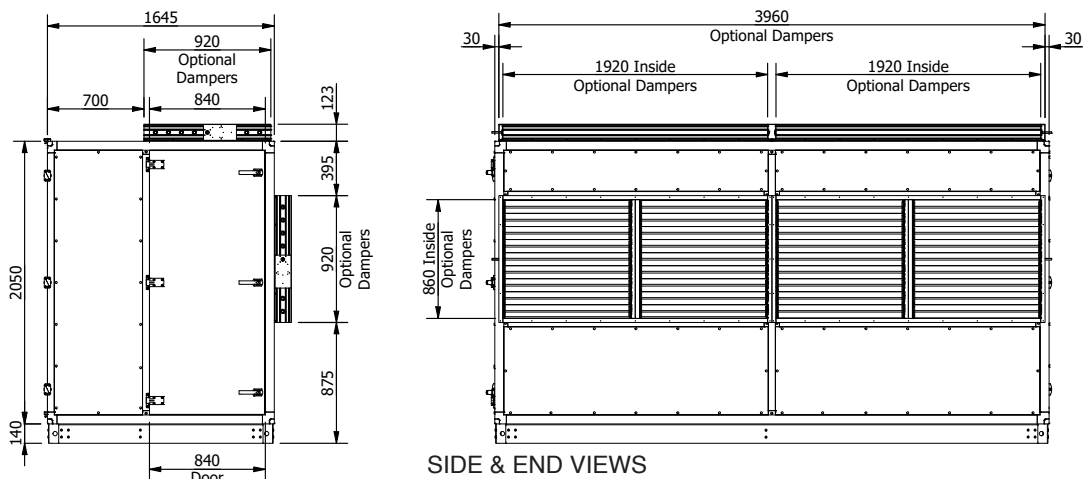

### NOTE

Specifications are subject to change without notice due to the manufacturer's ongoing research and development programme.

# WIRING

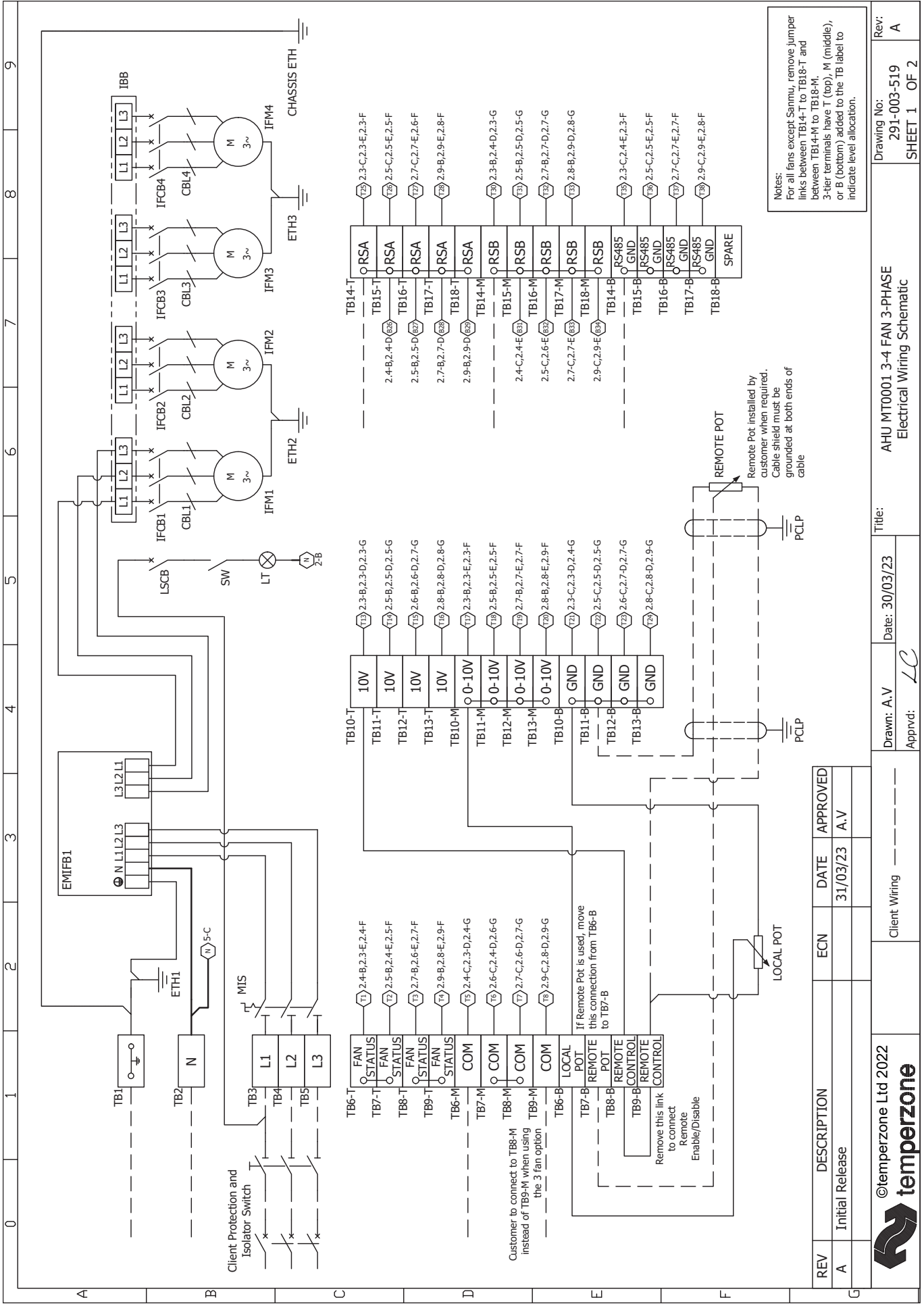

Notes:  
 For all fans except Sanmu, remove jumper links between TB14-T to TB18-T and between TB14-M to TB18-M. 3-tier terminals have T (top), M (middle), or B (bottom) added to the TB label to indicate level allocation.

Remote Pot installed by customer when required. Cable shield must be grounded at both ends of cable

REV	DESCRIPTION	ECN	DATE	APPROVED
A	Initial Release		31/03/23	A.V

©temperzone Ltd 2022

Client Wiring

Drawn: A.V  
 Approved: LC

Date: 30/03/23

Title: AHU MT0001 3-4 FAN 3-PHASE  
 Electrical Wiring Schematic

Rev: 291-003-519  
 SHEET 1 OF 2

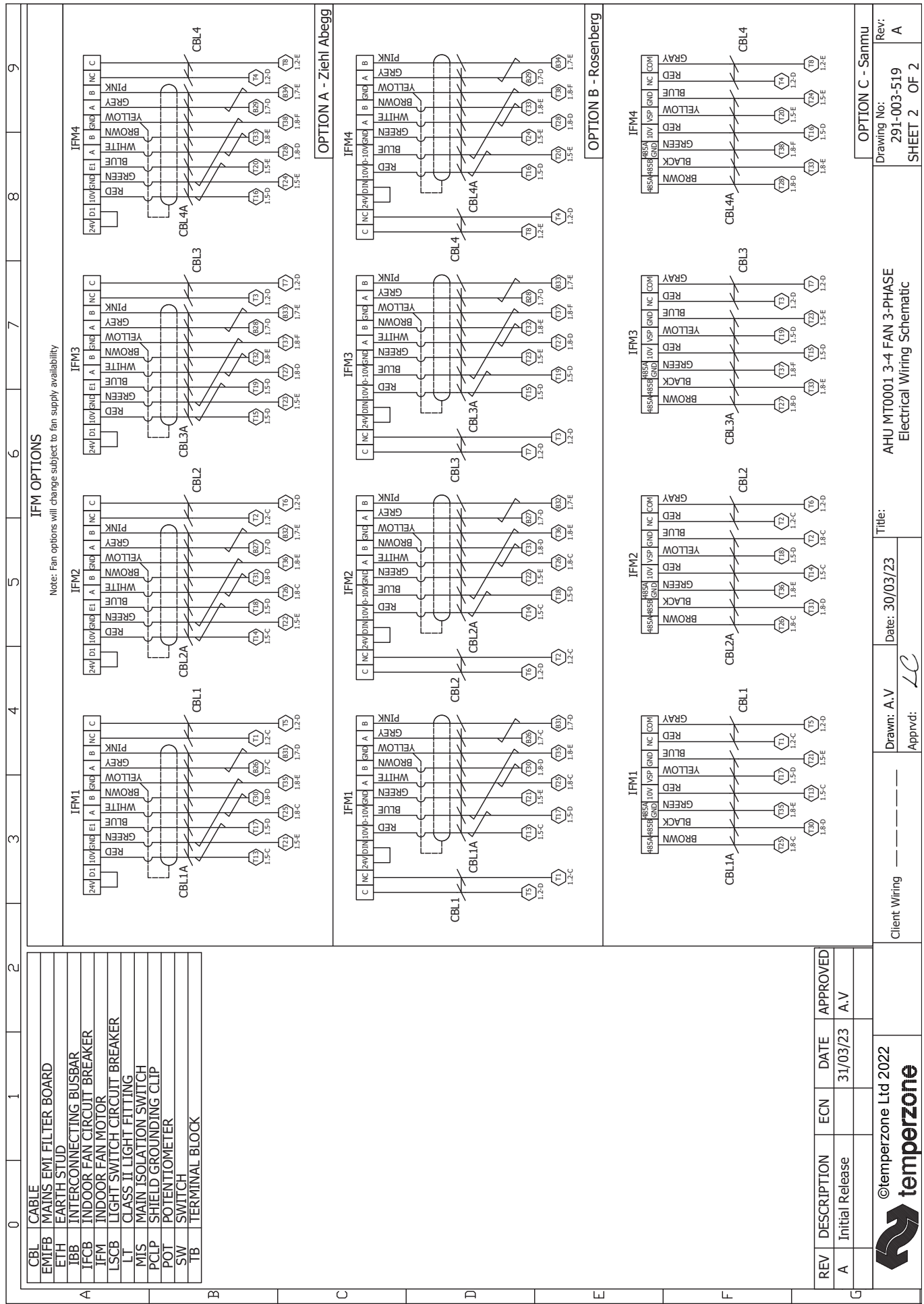

**IFM OPTIONS**

Note: Fan options will change subject to fan supply availability

CBL	CABLE
EMIFB	MAINS EMI FILTER BOARD
ETH	EARTH STUD
IBB	INTERCONNECTING BUSBAR
IFCB	INDOOR FAN CIRCUIT BREAKER
IFM	INDOOR FAN MOTOR
LSCB	LIGHT SWITCH CIRCUIT BREAKER
LT	CLASS II LIGHT FITTING
MIS	MAIN ISOLATION SWITCH
PCLP	SHIELD GROUNDING CLIP
POT	POTENTIOMETER
SW	SWITCH
TB	TERMINAL BLOCK

REV	DESCRIPTION	ECN	DATE	APPROVED
A	Initial Release		31/03/23	A.V

©temperzone Ltd 2022



Client Wiring

Drawn: A.V  
Appvd: LC

Title:

AHU MT0001 3-4 FAN 3-PHASE  
Electrical Wiring Schematic

Drawing No:  
291-003-519  
Rev: A

OPTION C - Sanmu

SHEET 2 OF 2