



aquanex
nex gen R32

Heat Pump Water Heaters

Applications Manual

MWS Series - Single-Pass Potable Water Heating models



Heating Capacity
25kW – 98kW



Heat Pump Water Heaters for Potable Applications

Contents

MWS SERIES	Page
General	4
Features	5
Design Philosophy	6
Thermal Stratification	6
Distribution Options	7
Performance	8
Design Considerations	9
System Design Considerations	10
Controls	11
Unit Selection	13
Site Requirements	15
Installation	16
Commissioning & Maintenance	17
Appendix I - External Piping Examples	18
Appendix II - Storage Tank Specifications	23
Contact Us	24

While this Applications Manual has been prepared and provided in good faith, Temperzone Ltd reserves the right to make changes at any time as part of its continuous improvement programme.

Note: Information in this document applies to UC8 controllers programmed with software version 4.06E or later.

Other relevant documents:

- MWS Product Overview
- MWS Installation & Maintenance
- MWS Specification Sheets
- R32 Refrigerant Handling: Water Heating Units

(Available at www.temperzone.biz)



Overview brochure available



Heat Pump Water Heaters Single-Pass Potable

MWS Series

Aquanex heat pump water heaters by Temperzone utilise the highest efficiency technologies to minimize energy consumption. The MWS Series is specifically designed to deliver heated potable water for large residential and commercial applications. They reduce dependence on combustion of fossil fuels by using clean energy sources. Durability and reliability are also key features.





Heat Pump Water Heaters

Single-Pass Potable

MWS Series

General

Introduction

Aquanex hot water heat pumps by Temperzone provide ideal heating solutions as we move to a sustainable future using cleaner energy sources. These heat pumps utilize the highest efficiency technologies to minimize energy consumption and not dependent on combustion of fossil fuels. Aquanex series heat pumps are specifically designed to deliver heated water to domestic and commercial applications only and can deliver up to 6 times the heating energy output for every unit of electrical energy consumed.

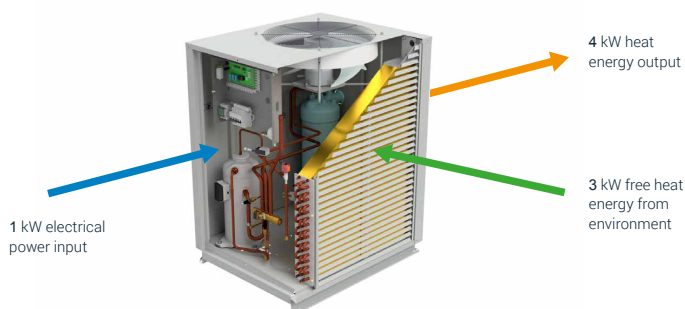

Figure 1

Purpose

The purpose of this Application Manual is to provide information and guidance during the design of your water heating system to ensure each MWS integrated system operates correctly and efficiently. Where a proposed design is not covered in this manual, please contact Temperzone for assistance (sales@temperzone.com).

Typical Applications

Reesidential, commercial kitchens, hostels, laundry, etc

It is suitable for meeting large peak hot water demands and can be retro-fitted to existing tanks (conditions apply).

Any application must comply with local/national codes and regulations.

⚠ IMPORTANT

The Aquanex MWS range is designed for use with **R32 refrigerant** (Class A2L) because of its low GWP. Refer to Installation Instructions for guidelines on the handling of units using R32 refrigerant, eg storage, ventilation and minimum floor area requirements.



Heat Pump Water Heaters Single-Pass Potable

MWS Series

Features

Lower GWP

MWS models utilise R32 refrigerant, which has significantly less Global Warming Potential (GWP 675 vs 2088) when compared to R410A units or fuel burning alternatives.

Energy Efficient

Each MWS system is comprised of a refrigeration system with highly efficient ThermoShell® heat exchanger to extract 'free' heat from the ambient air and transfer it to a water storage tank. Operation costs are significantly lower than a gas alternative.

The Aquanex Single Pass system surpasses the performance of multi-pass systems by being more efficient.

Heat exchange coils use inner grooved (rifled) tube for better heat transfer.

Performance

For every 1kW of energy input, up to 4 kW of energy output is produced. Water is heated in a single pass and in real time.

ThermoShell® Technology

The unit includes a compact long life highly efficient water heat exchanger design with non-fouling properties and has a low pressure drop compared to plate heat exchangers..

Compressor

Each high efficiency compressor is hermetically sealed, quiet running and supported on rubber mounts to minimise vibration.

Durable

Coil fins are epoxy coated for extra protection in corrosive environments, e.g. salt laden sea air. Each MWS unit's cabinet is constructed from high grade galvanised steel - polyester powder coated (grey) for all weather protection and is rated IP44/IPX4*. External fasteners are SKT® coated steel – marine grade.

Heat exchange coils comprise aluminium corrugated plate fins on mechanically expanded rifled copper tube.

Insulation

Units are insulated to prevent external condensation forming on the cabinet exterior. The insulation is foil faced and meets fire test standards AS 1530.3 (1989) and BS 476 parts 6 & 7. Internal piping is also insulated to minimise any heat loss.

Reduced Storage

The storage requirement of hot water is significantly reduced compared to conventional hot water heating systems, because of MWS's fast heating ability.

Quiet

The unit's coil design permits low fan speeds and hence low noise levels. The compressor is isolated in a built-in, insulated compartment to minimise noise.

Unit Protection

Units are fitted with a high pressure lockout that protects the unit in the event of water flow failure. Sensors protect against low air coil temperature and loss of refrigerant. Units include an anti-rapid cycle timer for compressor on/off protection.

Units also have a low refrigerant pressure sensor to protect against icing-up of the water within the unit's ThermoShell® condenser and a water pump flow verification input to protect individual units from a loss of water flow.

Each compressor has internal overload protection.

Wiring

A control panel, located in each MWS unit, is fully wired ready to accept the main power supply.

The electrical supply required is:

MWS 250: 1 ph. 230 V a.c. 50 Hz plus neutral and earth.
MWS 500/1000: 3 ph. 400 V a.c. 50 Hz plus neutral and earth.

Each system complies with the requirements of the Regulatory Compliance Mark (RCM) for electrical safety (AS/NZS 60335.2.40) and EMC (AS/NZS CISPR.14).

Provision has been made for compliance with DRED, ie demand response enabling device standard AS/NZS 4755.3.1.

Peace of Mind

Temperzone operates a quality management system that conforms to AS/NZS ISO 9001:2008. The company's products have been selected, against worldwide competition – chosen because of their proven efficiency, durability, performance, reliability and value.

Accessory

Drain connection kit (25mm OD) - supplied.

System Protection

1. HP and loss of refrigerant protection.
2. Anti-rapid cycle timer and internal overload for
3. Compressor protection.
4. Circuit breaker control circuits.
5. Time-and-temperature controlled electronic de-ice switch prevents icing up of the outdoor coil during heating cycle.
6. Sensor fault indication.
7. Compressor minimum run time to ensure oil return.
8. 12V control circuit.

Self Diagnostics

The Unit Controller (UC8) has a LED display to indicate faults and running conditions.

* Outdoor fan clearance <100mm (ref. IEC 60529)



Heat Pump Water Heaters

Single-Pass Potable

MWS Series

Design Philosophy

Designed for Better Performance

Designed for Cost Effectiveness

Designed for Durability & Low Maintenance

Background

The Aquanex MWS Series of heat pump water heaters units are designed to be the most efficient water heating option available, when integrated into an appropriately designed system. Where the electricity generation supplying the location has at least a moderate renewable energy component, heat pump water heaters have low to very low GHG emissions. Whilst the potential of heat-pump water heaters is well recognised, the technology has not been widely adopted due to several barriers to the market. These are cost effectiveness, reliability, durability and unproven performance in actual applications. Aquanex units have overcome these barriers and perform exceptionally well.

As awareness and increasing concern of the consequences of anthropogenic climate change spreads, the renewable energy proportion of electricity generation is increasing in most countries. Heat-pump water heaters are ideally suited for reducing the long term GHG emissions from water heating, particularly when combined with non-fossil fuel generated electricity. Choosing a heat-pump water heater today will substantially reduce the GHG emissions from your building over the gas alternative, and for many years to come.

Temperzone set out to develop a range of heat-pump water heaters to mainstream this technology in the market. Several years of Research and Development have created the Aquanex Single Pass range of products; designed to systematically overcome each of the barriers to market this technology encounters. Single Pass water heaters heat the cold water to the required temperature in a 'single pass' and delivers this water to the top of the tank. They heat the tank from the 'top-down', whereas most water heaters heat from the 'bottom-up' of the tank.

Storage Heated Water Systems

Storage based systems use tanks to store the heated water as the water heater capacity is insufficient to meet the peak instantaneous hot water demand. This allows the system time to recover during the lower demand periods of the day. Sufficient capacity in the storage tanks is required to meet the peak demand period of the heated water system. The peak demand period is typically over 2-3 hours, depending on the building application. Different building types will have the peak demand period at different times of the day. Residential buildings will typically have the peak demand period between

6 – 9 am, whilst restaurants will be during the evening. Businesses with highly seasonal demand (eg tourism and recreational industries) will require the heated water system to meet the peak demand period of the peak season.

Recirculation Systems (Ring-Mains)

Most large buildings have recirculation systems (ring-mains) to distribute the hot water continuously around the building. This reduces the time for hot water to be available at each outlet, however the heat-loss from these systems can be very high if poorly designed. Ring-mains present particular design challenges for heat-pump water heating systems as the returning water is mixed with the stored water. For gas and resistance heated systems, the efficiency of the heating is not affected by the temperature of the water being heated. Therefore, the mixing of the water in the tanks has no impact on the overall efficiency of the system. The efficiency of heat-pump water heating systems however is significantly affected by the temperature of the water, with the system being most efficient the colder the water being heated is. Therefore, the mixing of the water in the storage tank by ring-main systems needs to be avoided through design, to maintain the natural thermal stratification of the storage tanks.

Thermal Stratification

How do thermally stratified tanks work?

Heated water storage tanks are usually designed on the 'push through' principle. The pressurised incoming cold water enters at the base of the tank, and 'pushes' the hot water out of the top of the tank. This process allows for the formation of a stable layering of the two thermal layers within the tank, which is termed 'thermal stratification'. This allows the hot water temperature to be maintained at the outlet of the tank. Should the layers be mixed, then the hot water leaving the tank will become progressively cooler, leading to insufficient water of usable temperature remaining. The two water layers can be remarkably stable.

Over time, however, the two layers will become mixed. Factors which do not support thermal stratification to form must be avoided with Aquanex Single Pass water heaters. These factors are:

- Return of ring-main circulation systems to the bottom of the main storage tanks
- Use of electric resistance heaters at the bottom of the tank.
- Use of water jacket style heat-exchanger
- High velocities through the tank ports.



Heat Pump Water Heaters Single-Pass Potable

MWS Series

Design Philosophy

How Do Water Heating Systems Work?

Instantaneous Water Heaters

Conventional heated water systems are either instantaneous systems, or storage systems. Instantaneous systems require very high heating capacities as they need to meet the peak instantaneous demand for hot water from the building. This is the demand if most of the outlets are being used simultaneously when the incoming cold water is at its annual coldest for the location. These systems are almost always gas heated, as gas can deliver very high heating capacities. The gas heaters can either heat the water directly (eg gas califont) or indirectly via a calorifier.

Bottom-Up vs Top-Down Heating Systems

Bottom-up heating systems supply the heating energy to the coldest water at the bottom of the tank. This water steadily increases in temperature until it is within 2–3 °C of the next temperature layer above it, where the layers then are heated as a single layer. This continues until the tank reaches temperature set-point. During the peak demand period, the energy being added to the tank heats the incoming cold water, and does not contribute to hot water supply. The total peak demand period hot water requirement is therefore required to be met through storage.

Top-down heating systems heat the water to the desired temperature in a single 'pass' through the heat-exchanger. The hot water produced during the peak demand period is available for use during that period, as the cold water at the base of the tank remains cold until the final stage of tank heating. The volume of hot water storage required is the total peak demand period requirement, less the real time hot water production. The real-time production of hot water produced by the Aquanex Single-Pass heat pump water heaters is dependent on both environmental conditions and the temperature of the incoming cold water. The storage volume required is typically reduced by 25–50% depending on application and location.

System Design

These Aquanex Single Pass heat-pump water heaters have been designed to be integrated into efficient, cost effective, durable and reliable heated water systems with the following advantages:

- Designed to be installed as part of a new, or existing heated water system
- Top down heating extends the hot water service provided by the stored volume of water. The amount of storage required to meet a design peak demand profile is significantly reduced.
- Suitable for integration with demand management systems, particularly in combination with Solar PV installations.

Heat pump water heaters have particular requirements which must be met for these systems to operate efficiently, and for the system to exceed market expectations for durability. Heat pump water heaters are not a 'plug in' replacement for electric or fossil fuel heated systems, and the design of the heated water system typically needs to be modified slightly as a result. The Aquanex Single Pass system can readily be configured for both new and existing heated water systems by following the following design guidelines.

The key design principles to be maintained when integrating Aquanex Single Pass systems into heated water systems are:

1. Thermal stratification of the storage tanks must be maintained both during the tank heat-up cycle, as well as between heating cycles
2. Multiple storage tanks (if used) must remain balanced, both on the hot/cold water supply/delivery side as well as the heat pump flow and return.

MWS Systems

MWS units have inlet and outlet water temperature sensors plus a storage tank temperature sensor provided. The units have a variable speed pump which is controlled to maintain a constant target outlet water temperature with set speed compressors fitted in different configurations depending on model.

The flow rate of variable speed pump combined with set speed compressor at target constant outlet temperature and ambient conditions determines the capacity required.

Ambient air temperature available determines heat energy that the heat pumps compressor can absorb and influences the pump speed to achieve the target outlet water temperature (LWT).

Under low heating demand conditions where the inlet water temperature is rising close to outlet water temperature (temperature split is reduced) the pump will be increasing in speed to achieve the LWT. Should the LWT exceed target outlet temperature for period of time and by a set value, with pump at maximum flow rate or the temperature split across heat exchanger is less than 5K, then unit will stop heating.

The unit will also stop heating if the tank sensor in specific location of storage tank/ cylinder, senses water temperature at sensor location exceeds set value, with a default of 35°C at the sensor location of a stratified storage tank.

Units can also be commanded on and off via remote control circuit provided. Standard Modbus communication ability and control via an external BMS.



Heat Pump Water Heaters Single-Pass Potable

MWS Series

Distribution

Distribution Options

Satellite Storage Tank/s

The MWS range is designed to deliver a continuous supply of heated water at 62°C during operation. The unit has an inlet and outlet water temperature sensor, and the inverter speed is controlled to maintain a constant target outlet water temperature. Ambient air temperature determines the heat generated by the system, at a fixed compressor speed, when combined with the inlet and outlet temperatures.

Under low heating load conditions, the compressor will continue to operate but at a higher flow rate. Should the heating output at maximum flow exceed the heating demand, the compressor will stop operation. This feature prevents short cycling of the system under low load conditions.

In order to maximize the efficiency of the system, the following factors are required to be considered:

- Ambient air temperature and humidity. Hot water production and efficiency (COP) increases with increasing temperature and humidity.
- Inlet water temperature. The efficiency increases with decreasing inlet water temperature however hot water production decreases with decreasing water temperature.
- In most climates the efficiency of the unit will be similar during winter and summer. The decrease in COP with decreasing ambient temperature is offset by the decrease in the cold water inlet temperature. In particularly cold climates, the energy required for de-ice cycles impacts on the winter time energy efficiency. These locations typically have hot summers, which increase summer operating efficiencies.
- Daytime operation is generally more efficient than night-time operation, due to the warmer ambient conditions.
- Stainless steel tanks, especially duplex tanks, enhance system efficiency due to the stable thermal stratification maintained by these tanks. Duplex stainless steel tanks have particularly thin walls due to the strength of their material.

These factors will be explained in more detail in the following pages.

Ring-Main Compatibility

The purpose of a potable water 'ring-main' is to provide hot water via a loop to tempering points within a building.

To comply with legionella prevention regulations, the ring-main water loop is at least 60°C, or above, at the point-of-entry to any water tempering device take-off's from ring-main loop.

The ring-main is fed with pre-heated potable water from a stratified tank heated via heat pump, when there is draw off from ring-main supply loop.

Our MWS potable water heating heat pumps are designed to heat a stratified HWC/storage tank/cylinder and it is **not suitable to attach a ring-main direct** to HWC/storage tank/cylinder, while heat pump is heating, as it will cause turbulence within the HWC/storage tank. The exemption to this is the use of a dual tank (2-in-1) that effectively prevents turbulence.

Any ring-main system installed with an MWS heat pump must be attached:

- a) to a separate tank for ring-main circulation, with ring-main pump, plus boost elements to control ring-main temperature requirements, or
- b) attached to a dual tank/cylinder arrangement, that allows heat pump to heat lower tank, with hot water entering bottom of upper ring-main tank when there is draw off from ring-main loop. Dual tank ring-main flow and return lines are only connected to the upper ring main tank of dual tank storage cylinder, which would also accommodate a boost element for ring-main top-up temperature control.

There are configurations for ring-main tanks when multiple storage tanks are used to supply potable hot water. Please contact our office for further information.

Refer External Piping Examples that include ring-main – diagrams 2, 4 and 6 diagrams (starting page 23).



Heat Pump Water Heaters

Single-Pass Potable

MWS Series

Design Considerations

Storage Tanks

One or more hot water storage tanks are an integral part of an overall system. Refer page 13 for information on Storage Tank efficiency, types and specifications.

Note: MWS units are not compatible with water jacket (tank-in-tank) heat exchange systems, or as part of a secondary heating circuit

Multi-Tank Installations

Commercial heated water installations often require the use of multiple tanks to achieve the required storage volume. Typically, multiple smaller tanks are more cost effective than very large tanks, and often access into plant rooms limits the maximum practical width of the tanks. For Aquanex Single Pass water heaters to function correctly, the installation of the tanks must allow for balanced flows through each tank, during both hot water draw-off, and reheating. The tanks should be plumbed in a parallel configuration to reduce the internal velocities through the tank that would result in a series connected system. Reverse return pipe arrangements on both the hot and cold water supply, and the heat-pump supply / return is essential for Aquanex Single Pass heat-pump water heaters.

Tank Installation Types

The tank configuration must allow the natural thermo-stratification of the tank to be maintained throughout the tank heat-up process. Thermal stratification refers to the natural tendency of the hot water remaining in the tank to 'float' on top of the cold water at the bottom of the tank.

Refer Appendix I, p 19 for examples of typical tank installations:

1. Single tank (for MWS 250/500)
2. Single dual tank & ring-main supply (for MWS 250/500)
3. Single tank (for MWS 1000)
4. Single dual tank & ring-main supply (for MWS 1000)

Contact Temperzone to discuss your own individual requirements, especially in regard to retro-fit installations.

Efficiency

The key factors which determine the efficiency and the functionality of the Aquanex Single Pass systems are:

- Ambient air temperature and humidity.
- Hot water production and efficiency (COP) increases with increasing temperature and humidity. Daytime operation is generally more efficient than night-time operation, due to the warmer ambient conditions.
- Inlet water temperature.
- The efficiency increases with decreasing inlet water temperature however hot water production decreases with decreasing water temperature.
- In most climates the efficiency of the unit will be similar during winter and summer. The decrease in COP with decreasing ambient temperature is offset by the decrease in the cold water inlet temperature. In particularly cold climates, the energy required for de-ice cycles impacts on the winter time energy efficiency. These locations typically have hot summers, which increase summer operating efficiencies.
- Stainless steel tanks, especially Duplex tanks enhance system efficiency, due to the stable thermal stratification maintained by these tanks. Duplex stainless steel tanks have particularly thin walls due to the strength of the material.

Where possible, consider these factors when designing systems integrating the MWS.

AVOID the following:

- Installations where a micro-climate develops around the unit (ie too closed-in areas).
Ensure the unit's cold dispensed air can be effectively dispersed from the surrounding area.
- Restricted Air Flows
Installations where plants or other objects restrict air-flow through the unit coils. The de-ice settings assume the unit coil has an unobstructed supply of air and the minimum clearance is adhered to. Ensure fences, etc., around the unit do not create a micro-climate around the unit, eg pooling of cold air. Cold air must be free to drain away from the site.
- Under-sizing of piping to the storage tank.

Locate the unit as close as practical to the storage tank, and limit the number of 90 degree bends used.

MAKE USE OF the following:

Higher outdoor ambient temperatures can be used to your advantage. On site controllers often have time scheduling. The MWS can be used as part of a wider demand management strategy. This is of particular benefit where a solar PV system is installed, and the morning hot water recovery is delayed to coincide with the daily peak solar generation period.



Heat Pump Water Heaters

Single-Pass Potable

MWS Series

System Design Considerations

Demand Management

Top-down heating systems produce usable water shortly after the unit begins operation. This feature allows for flexibility in managing the operation of the unit to enable demand management objectives to be met. This is particularly applicable to buildings with significant solar PV installations, where the recovery of morning hot water usage can be deferred to coincide with the daily solar generation peak period, whilst maintaining security of hot water service.

Supplementary Heating

Supplementary heating is used to increase the heating capacity of the system, particularly during low ambient temperature conditions where the heat-pump water heater capacity is reduced. When correctly integrated into the system design, supplementary can be a cost effective method to meet a design hot water demand. Design hot water demands are in practise only rarely required by the system. On an annualised basis, the proportion of energy required by the hot water system that is met using supplementary heating should not exceed 5%.

Annual Performance

Annual energy savings of a heat pump water heaters provides the information required to assess the economic benefit of choosing between the different water heating options. This methodology is similar to that used for the annual energy performance, except the climate, and hot water demand profile for a specific application (building) is entered into the model.

Thermal simulation modelling of a project allows the correct unit and storage capacity to be selected to meet a specified hot water demand. In colder climates, thermal simulation allows for the optimum integration of supplementary heating. Temperzone can assist with this selection process by directing you to an appropriate consultant.

Thermal Simulation

Long term operational cost savings can considerably outweigh initial capital cost of an installation.

The annual energy performance of heat-pump water heaters can be determined through thermal simulation modelling. AS/NZS4234 describes the methodology based on the *TRNSYS* thermal simulation system. *TRNSYS* enables the components of the heated water system to be specified in *TRNSYS* modules. The system is particularly flexible, allowing most systems to be accurately simulated. It should be noted that generic thermal simulation models usually assume the tank is heated from the bottom, and therefore will not accurately model a top down system.

Should *TRNSYS* be used to simulate the heated water system, the following performance parameters based on the methodology described in AS/NZS5125 will be required:

A1	A2	A3	A4
B1	B2	B3	B4

Frost penalty: 23%, from 7°C.

Sizing

These units deliver 62 °C hot water to centralised water heating systems. They require a cold water supply, and connection to a thermally stratified storage tank. Potable water heating systems must deliver sufficient hot water to meet the 'peak demand' of the application. The peak demand only occurs occasionally, but the capital investment required is fixed at this capacity. MWS units contribute significantly to real time hot water demand, and therefore can be used to reduce storage capacity required, and therefore increasing their cost effectiveness.

Compliance

Any application must comply with local/national codes and regulations, including the following.

- AS/NZS 4020 for contamination control,
- AS 3498 or G12/AS2 of the NZ Building Code for Legionella protection. MWS units are designed to comply when installed correctly.

WaterMark is a certification mark provided by independent certifying authorities. It confirms the product: complies with the Plumbing Code of Australia meets relevant Australian Standards relating to product quality, including health and safety. MWS units manufactured for Australia are pending WaterMark Certification.

There are several key compliance requirements covering heat pump water heaters, with some differences in the requirements between New Zealand and Australia. For detailed compliance requirements, please consult the legislation of the Country (and State).

Commercial kitchens typically require that the water at the tap is heated to 65°C. Since this temperature is higher than that produced by the heat pump water heaters, supplementary heating is typically required for these premises. This is best achieved using a satellite electrically heated tank close to the kitchen outlet, which is supplied with preheated water from the main storage tanks. Instantaneous gas water heaters are less suited for this application because the temperature rise required of 5°C leads to short cycling of the appliance.



Heat Pump Water Heaters Single-Pass Potable

MWS Series

System Design Considerations

Legionella Control Requirements

Australia:

Heated water systems are required to be installed in accordance with AS 3498: Authorization requirements for plumbing products - water heaters and hot-water storage tanks. There are a range of Legionella control options available, depending on how long the water is stored at a particular temperature. Compliance is most readily achieved to (j)(ii) in AS 3498:

(j)(ii) For a heat pump water heater, at least 45% of the water contained within the storage tank is heated to a minimum of 60 °C daily.

New Zealand:

The Acceptable Solution G12/AS2 is the most practical means of demonstrating Legionella control compliance to the Building Code. Whilst G12/AS2 specifically refers to solar water heaters, the underlying principle is applicable to heat pump water heaters. The Aquanex Single Pass systems, when correctly installed, are designed so a temperature of 60 °C is achieved within 45% from the top of the tank at the completion of the heating cycle. In addition, at least 80% of the water in the tank is heated to at least 60 °C during each heating cycle.

3.5.1 To prevent the growth of Legionella bacteria, solar water heaters must either:

- a) have a continuously energised heating element fitted with 55% of the bottom of the water tank (by volume) and a thermostat set to 60 °C or higher, or
- b) be controlled so that the water above the element is heated to 60 °C once a day, and the element is in the bottom 20% of the water tank (by volume) and no more than 150 mm from the bottom of the tank.

The Aquanex Single Pass water heaters require a tank sensor to be within the lower 30% of the storage tank (by volume). When this sensor senses that the lower part of the tank is cold, the unit will commence heating cycle. The heating cycle ends when a sensor in the water heater inlet is hot. Due to the top-down heating design, this ensures that a full tank of hot water is achieved at the end of each heating cycle. It should be noted that this requires that multiple storage tanks (if installed) are balanced, and thermal stratification is maintained.

Thermosiphoning

Top-down heating systems require a connection to the top of the tank. Where the water heater is positioned higher than the base of the tank, there is a tendency for heated water to flow from the tank to the water heater when the water heater is not operational. Airlocks can also form at the highest point in the pipework.

The MWS 250 unit must be installed level with, or below, the base of the storage tank. External check valves (aka non-return valves) must not be used with this unit.

The MWS 500 model has internal check valves to prevent this occurring. The MWS 1000 model has twin compressor systems with an internal de-ice design which is designed for check valves to be installed on the heat-pump water heater supply and return pipes.

MWS 250	Not compatible with external check valves
MWS 500	Internal check valve supplied
MWS 1000	External check valve required

Retrofitting To Existing Heated Water Systems

The MWS Single Pass units are designed to be retrofitted to most existing heated water systems. This is typically more cost effective than replacing the existing tanks, unless the tanks are at the end of their design life. In most cases however, design changes are required to the ring-main return, and to ensure a balanced flow through the system. Where there are no suitable ports at the top of the tank, the heat-pump outlet can be teed into the hot water outlet of the tank, provided there is an in-line tank (usually the ring-main return tank) between the main storage tanks and the hot water outlets.

Other considerations include appropriate space and clearances for the unit and any boundary noise restrictions for when the unit is operating.

Pipework

The Aquanex Single-Pass systems operate with a large temperature differential across the heat-exchanger. This substantially reduces the maximum water flow-rates through the system during heating allowing 20 – 25mm pipework to be used in most installations. This represents a significant cost reduction compared with high flow, low temperature differential conventional heat pump water heating systems



Heat Pump Water Heaters

Single-Pass Potable

MWS Series

System Design Considerations

Positioning & Mounting

Positioning and mounting instructions are covered in the unit 'Installation & Maintenance' instructions.

The MWS unit should ideally be installed outdoors. The base of the unit must be at the same level, or lower, than the base of the storage tank. If this is not possible, consult Temperzone on the necessary modifications to your piping system (eg adding an auto air bleed, check valves).

Where the preference is an indoor location (eg in a Plant Room), sufficient ventilation must be provided to maintain the internal air temperature no lower than 5°C below the external ambient air temperature. It is possible to duct the exhaust air from the unit, however the external static at the fan must be less than 5 Pa. If ducting the exhaust air, it is recommended that an additional in-line fan be installed in the duct to maintain airflow through the unit.

In all installations, it is preferred that the coil be installed perpendicular to the wall. In installations where this is not possible, the coil must be installed a minimum of 500 mm from a wall. There must be no restriction to the airflow above the unit.

Multiple units installed side-by-side must have a minimum of 1 metre clearance between coil faces.

Note: The exhaust air from the unit is very cold when the unit operates at full capacity, and may be well below the freezing temperature. Take care when selecting the installation position that the exhaust air from the unit will not be under a window or plants which are cold sensitive. It is possible to get condensation on surfaces above the unit exhaust air which may deteriorate some surfaces.

R32 Refrigerant Requirements

There are special requirements for customised models that use refrigerant R32. Refer our 'R32 Handling' document.

Correct Pipe Sizing

Pipe lengths should be as short as practical, and match the connection sizes on each product; refer Specification Sheet for each model (available at www.temperzone.biz).

Maintain the same inner bore diameter throughout the piping system. Restricted flow rates may result in over-pressure (HP) faults occurring.

All external piping should to be insulated to minimise any heat loss in cold ambient conditions.

Controls

Aquanex MWS Series heat pumps incorporate a proprietary UC8 unit control module with sophisticated software installed specific to the application of potable water heating.

The MWS unit can be installed as a turnkey solution, ie no intervention required. The unit is pre-wired for dry contact remote on/off operation. Just connect water and power on.

It is also possible to BMS control the MWS through RS485 Modbus communications, including multiple units.

Refer Installation & Maintenance pamphlet or contact Temperzone for assistance.

Operational Requirements

The Aquanex Single Pass unit are designed to be direct connected to heated water storage tanks. The units are not compatible with water jacket (tank-in-tank) heat exchange systems, or as part of a secondary heating circuit.

Temperzone can supplied a dedicated storage tank that meets all the stratification requirements of a complete system.

The inlet of the heat pump water heater must be connected either to the cold water supply to the tank, downstream of any non-return or cold water expansion valves. The outlet of the water heater is connected either to a dedicated port in the top 20% (by volume) of the tank, or teed into the hot water outlet. A single temperature sensor (supplied) is inserted into a thermal sensor pocket approximately 30% from the bottom of the tank (by volume). If a sensor pocket is not available, then insert the temperature sensor between the insulation and the inner tank wall at the correct position. This may require drilling a hole through the outer tank wall.

Warning: Do not damage the inner tank wall. Ensure good contact with the inner tank wall surface, and replace the insulation between the sensor and the exterior of the tank.

During normal operation, the water heater will begin operation when the temperature of the water in the tank at the position of the is less than 35 °C. The unit compressor will start, and within 2 minutes, the unit will be delivering a constant supply of hot water to the top of the tank. This water is layered on top of the existing water in the tank, with the cold water being drawn from the base of the tank through the unit. This process continues until the temperature sensor within inlet of the unit reaches 35 °C. The unit will stop operating, and return to standby mode.

MWS Specification Sheets include such detail as:

- required water flow rate,
- minimum/maximum inlet temperature,
- minimum operating temperature,
- maximum operating pressure.

and are available at www.temperzone.biz



Heat Pump Water Heaters Single-Pass Potable

MWS Series

Unit Selection

De-Ice Cycle

As a normal consequence of operation, during low ambient periods, ice will form on the external heat-exchanger of the unit (outside coil). The ice will gradually increase in thickness until the unit requires a de-ice cycle. During de-ice, the compressor will reduce in capacity, and the fans will stop operating.

Depending on the model, a second de-ice pump will operate, pumping water from the top of the tank, through the system, to provide energy to de-ice the coil. Once the ice has been removed, the unit will enter a dry cycle, before recommencing heating operation again.

During very low ambient conditions, the hot water supply temperature will reduce by a few degrees. This is to protect the compressor from excessive compression ratios, and to limit maximum refrigerant temperatures. This slightly increases the rate of hot-water production, and the operating efficiency under these conditions. Legionella control is maintained as it is unlikely that all heating cycles, within a 7 day period, occur during very low ambient conditions.

The MWS 500 models have a de-ice bypass valve, which operates during the de-ice cycle. The MWS 1000 models do not require a de-ice pump as these models use an internal de-ice system. The MWS 500/1000 tandem compressor models operate only 1 compressor per refrigeration system during de-ice.

Supplementary Heating

Supplementary heating is used to increase the heating capacity of the system Refer page 8 for more information.

Backup Heating

An optional use relay on the UC8 control board can trigger backup electric elements to operate in the storage tank when there is a fault with the unit (refer Installation & Maintenance document).

Hot Water Demand

Sizing a heat pump is based on 'peak' hot water demand. The hot water demand for an application depends on the nature and location of the building. System designers should consult the project Building Services Engineer for the design hot water demand. Where this service is not available, the table below provides a general guide as to expected hot water demand for common applications.

Type of Building	Total daily demand. (l/person)	Peak demand (l/person)	Peak demand period (hours)
Residential – premium	75	45	6 – 10am
Residential – mid-range	75	40	6 – 9 am
Residential – entry level	50	35	6 – 9 am
Residential – backpackers	60	30	6 – 9 am
Aged care	40	30	7 – 11 am
Restaurant – Premium	30	20	6 – 11 pm
Restaurant – mid-range	20	15	6 – 11 pm
Restaurant – fast food	10	10	6 – 12 pm

Seasonal Demand

Many businesses experience considerable seasonal variations in the demand for their services. Businesses in the tourism, hospitality, winter sports and beach resort industries are particularly affected by seasonal demand. It is therefore important to consider the effect of seasonal demand when designing a system. For example, a summer resort application will focus on the real-time hot water production, and will design for a significantly warmer ambient condition than the lowest ambient temperature for that location. A winter ski resort will require significant storage capacity since the real-time hot water production will be impacted by the low ambient temperatures during the peak skiing season. An urban backpacker's accommodation might use supplementary heating to increase heating capacity should the hostel be fully occupied on the occasional winter's night, as this is more cost effective than adding additional storage capacity.

The Aquanex Single Pass systems rely on the thermal stratification being maintained in the tanks. Designing systems with excessive storage capacity results in a less efficient overall system as storage heat losses increase, and there are less frequent tank heating cycles to re-establish the thermal stratification in the storage tanks.



Heat Pump Water Heaters Single-Pass Potable

MWS Series

Unit Selection

Climate Zones

Climate has a significant effect on the minimum performance levels of these units, and therefore the Australasian region is separated into three zones.

Zone 1: South East Asia, and Northern Australia and Queensland

Zone 2: Rest of Australia, except Tasmania and Canberra. Coastal North Island of New Zealand.

Zone 3: Tasmania, Canberra, central North Island and South Island of New Zealand.

The MWS range comprises a 20 kW, 40 kW and 80 kW, 3 phase models. It is important to select the appropriate sized unit for 'peak' hot water demand. Over-sizing of units is not recommended, as ideally the heating demand should match the operating range of the compressor. If the heating demand is too high for the capacity of the unit, then the compressor will operate too long. If the heating demand is too low, the compressor will typically cycle too frequently between on/off.

For operational limits refer to the Product Review brochure and/or Specification Sheet for each model available at www.temperzone.biz.

Specification Sheets include such detail as:

- required water flow rate,
- minimum/maximum inlet temperature,
- minimum operating temperature,
- maximum operating pressure.

Refer 'Performance' section (p.8) on how to maximise efficiency and what to avoid in your system design. A combination of the two will lower running costs and extend the life of your system.

Storage Tank Selection

The three main materials used for tanks are copper (low pressure systems), enamel lined mild steel, and stainless steel. Heat is transferred from the hot water layer to the colder layers predominantly down the walls of the tank. There is minimal heat transfer directly through the water layers. Therefore, the thermal conductivity of the tank material, and the thickness of the tank walls are important determinants in how stable the thermal layers will be within the tank.

Copper has the highest thermal conductivity (400 W/mK), followed by mild steel (50 W/mK). Stainless steel has the lowest thermal conductivity (16 W/mK). In addition, the wall thickness of mild steel tanks is typically 2-3 x the thickness of stainless steel tanks. Therefore, the stainless steel tanks are significantly better at maintaining thermal stratification than the other alternatives. They are also much more durable, and are strongly recommended for use with Aquanex Single Pass heat-pump water heaters.

For your convenience, Temperzone has a special arrangement with a tank supplier who can provide tanks to meet the MWS matched specifications that will optimise the performance of your system. Combined MWS and tank packages are available or you can use the Tank Specification (Appendix II, p23) to supply your own.

Note: MWS units are not compatible with water jacket (tank-in-tank) heat exchange systems, or as part of a secondary heating circuit



Heat Pump Water Heaters Single-Pass Potable

MWS Series

Site Considerations

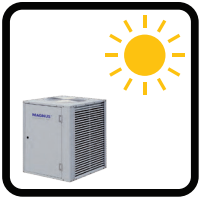

Aquanex heat pumps utilize the refrigeration process to extract heat from ambient air and deliver that heat to a duty requirement. The heat pump operates most efficiently at the highest ambient air temperature during the day.

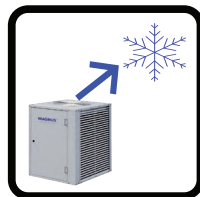

The air discharging from the unit is quite cold and possibly below freezing temperature at low ambient conditions. Care should be taken that this air is not discharging under windows or plants which are sensitive to the cold. It is possible that condensation will form on surfaces above the unit so be cautious that these surfaces are not sensitive to deterioration from moisture.



Avoid installation in closed-in areas where the air recirculates through the unit and a cold micro-climate can develop around the unit diminishing its performance. If a unit is to be installed in an enclosed room or space (eg plant room, enclosed courtyard), then that space should be ventilated to prevent the enclosure temperature falling to less than 5 degrees below outside ambient temperature. The fan discharge from the unit may be ducted directly to outside the enclosure provided the air flow resistance does not exceed 25Pa. A boost extract fan may be required. Refer to Temperzone for advice on duct sizing.



It is a normal process for ice to form on the evaporator coil during operation at ambient temperatures below 5 degrees. Each Aquanex heating unit has a fully automated de-ice system.

Condensation will generally be continuously running from the unit during operation – more so after a de-ice cycle has been completed and a large volume ice has been melted off the coil. Care should be taken with the installation where this condensate runs off to. If this condensate is likely to form a hazard on an access path then the unit should be placed in a drip tray and drained to a waste point.

Any application and installation must comply with local/national codes and regulations.

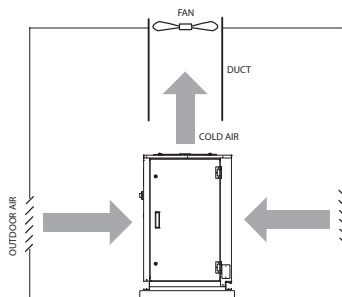

Plant room

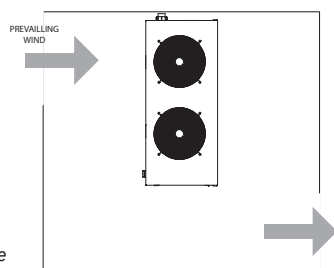

Enclosed space



Heat Pump Water Heaters Single-Pass Potable

MWS Series

Installation

Refer to the MWS 'Installation & Maintenance' document supplied with each unit for full details (available at www.temperzone.biz).

The Aquanex MWS heat pump should be mounted on a rigid base or foundation and set on rubber vibration isolation pads. Allow sufficient space around the unit to facilitate water pipe connection, future service, and maintenance requirements, working space in front of the electrical panel and unobstructed air flow through the unit. Refer to the minimum clearance requirements illustrated below, and in the unit Specification Sheet (available at www.temperzone.biz).

In all installations it is preferred that the coil be installed perpendicular to the wall (Fig.3a). In installations where this is not possible, the unit must be installed with a minimum of 500mm clearance between the coil and the wall (Fig.3b).

If multiple units are installed side-by-side there must be 1m minimum clearance between facing coils. There must be no restriction to air flow above the unit.

Figure 3a Minimum Clearances

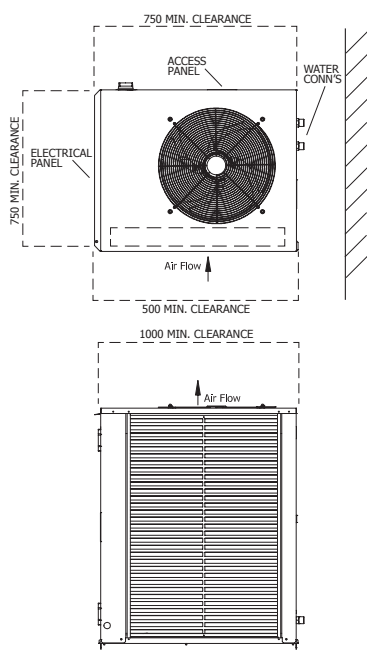
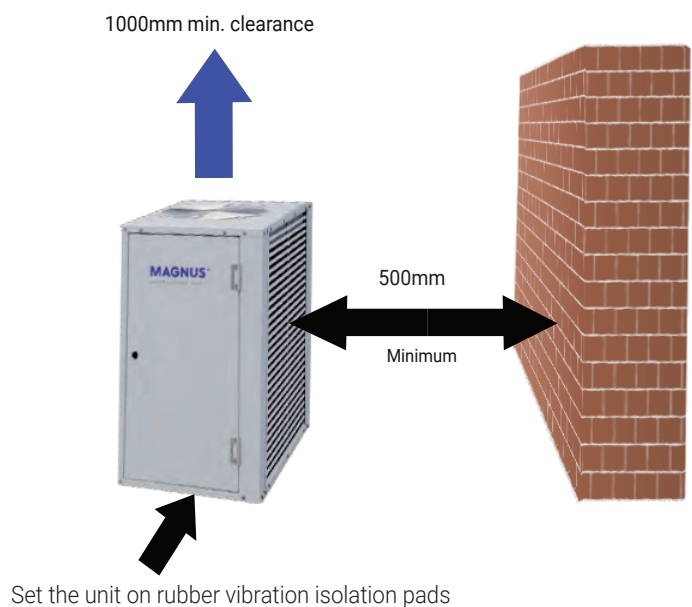

Figure 3b Alternative Orientation





Heat Pump Water Heaters

Single-Pass Potable

MWS Series

Commissioning & Maintenance

Troubleshooting

The Aquanex MWS range has a controller (UC8) that controls the refrigeration system to provide optimal performance, efficiency and durability. When operating conditions are outside of the limits of the system, the system will report a fault condition. Multiple reported faults indicate that the unit requires service support and the unit will display a 'lockout code'.

The most likely fault is a high pressure (HP) fault, which will occur if there is insufficient water flow through the unit.

The unit is programmed to operate on its own based on the following conditions:

System Start:

- Remote on/off input is closed circuit (dry contact)
- Inlet water temperature is greater than 5°C lower than the target set temperature.
- Ambient temperature is above -15°C

System Stop:

- Remote on/off input is open circuit, or
- Outlet temperature is greater than 2°C above the target set temperature and the compressor has operated at less than 20% for longer than 2 minutes.
- temperature sensor in lower position of tank has reached set point (35°C).

Refer to the MWS 'Installation & Maintenance' document supplied with each unit for full details (available at www.temperzone.biz).

Warranty & Technical Support

Please refer to the separate warranty document supplied with the unit, or visit www.temperzone.biz for details.

Australia:

warranty@temperzone.com.au
spares@temperzone.com.au
Telephone: 1800 21 1800

New Zealand:

nztechnicalsupport@temperzone.com
Telephone: 0800 TZWARRANTY (899 2777)



Heat Pump Water Heaters for Potable Applications

Appendix I

External Piping Examples

Examples of typical tank installations:

1. Single tank (for MWS 250/500)
2. Single dual tank & ring-main supply (for MWS 250/500)
3. Single tank (for MWS 1000)
4. Single dual tank & ring-main supply (for MWS 1000)

Contact Temperzone to discuss your own individual requirements, especially in regard to retro-fit installations.

Piping

The MWP Heat Pump should be located at close proximity to the storage tank as practicably possible. Keep pipe length as short as possible with as few bends and restrictions as possible. Restricted flow may result in high pressure faults occurring. Connecting pipework must be insulated to minimize heat losses and prevent freezing in sub-zero ambient temperatures.

Example 1

MWS 250, MWS 500 Single Tank Heating

TV - TEMPERING VALVE
PRV - PRESSURE RELIEF VALVE

MWS 250:
Single set speed compressor.
Variable speed circulation pump.
Defrost set speed circulation pump.
(Reverse flow in defrost).

MWS 500:
Tandem set speed compressors.
Variable speed circulation pump.
Defrost set speed circulation pump.
(Reverse flow in defrost).

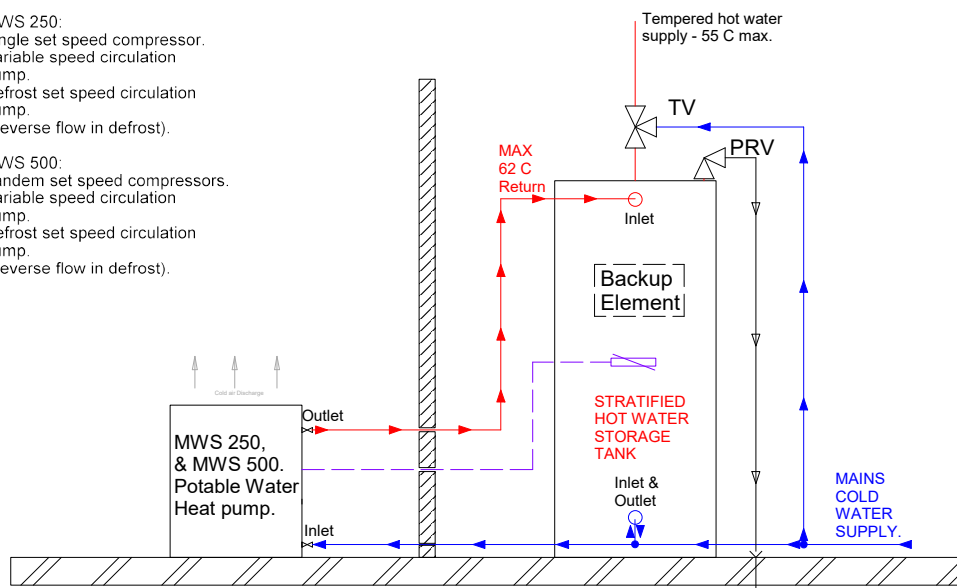

No check valves allowed in any installed pipe work between HWC and MWS heat pump Models MWS 250, MWS 500.



Heat Pump Water Heaters for Potable Applications

Appendix I

External Piping Examples

Example 2
MWS 250, MWS 500
Single Dual Tank Heating with Ring-Main Circulation

TV - TEMPERING VALVE
PRV - PRESSURE RELIEF VALVE

MWS 250:
Single set speed compressor.
Variable speed circulation pump.
Defrost set speed circulation pump.
(Reverse flow in defrost).

MWS 500:
Tandem set speed compressors.
Variable speed circulation pump.
Defrost set speed circulation pump.
(Reverse flow in defrost).

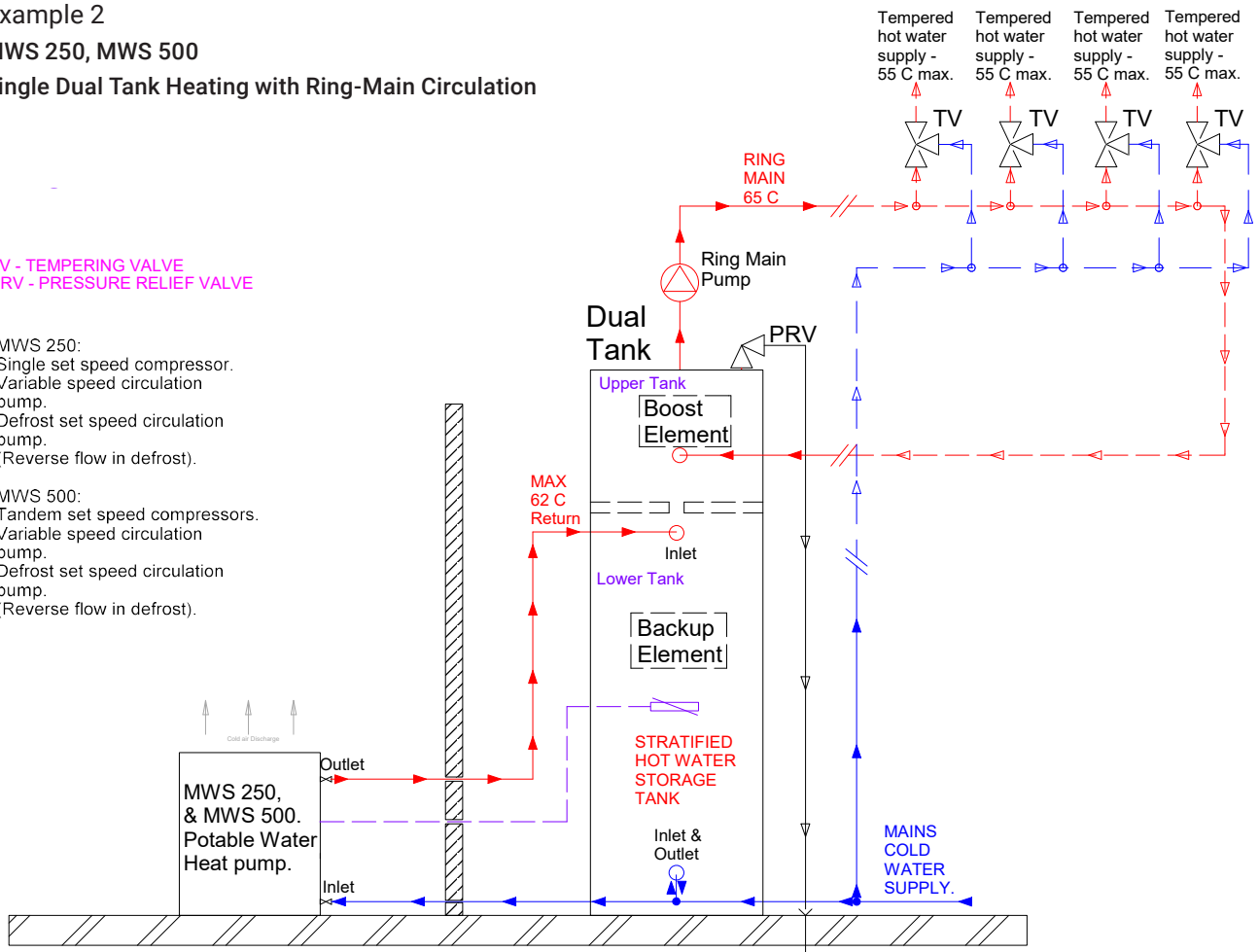

No check valves allowed in any installed pipe work between HWC and MWS heat pump Models MWS 250, MWS 500.



Heat Pump Water Heaters for Potable Applications

Appendix I

External Piping Examples

Example 3
MWS 1000
Single Tank Heating

TV - TEMPERING VALVE
PRV - PRESSURE RELIEF VALVE

MWS 1000:
2 x Tandem set speed compressors.
2 x Variable speed circulation pumps.

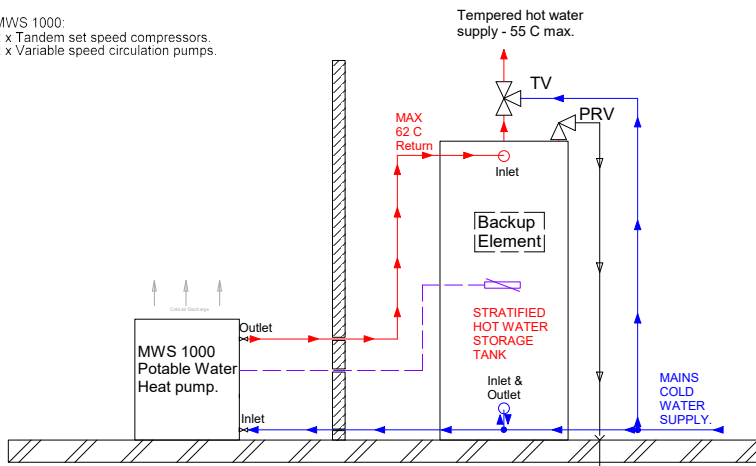

Example 3
MWS 1000
Single Dual Tank Heating with Ring-Main Circulation

TV - TEMPERING VALVE
PRV - PRESSURE RELIEF VALVE

MWS 1000:
2 x Tandem set speed compressors.
2 x Variable speed circulation pumps.

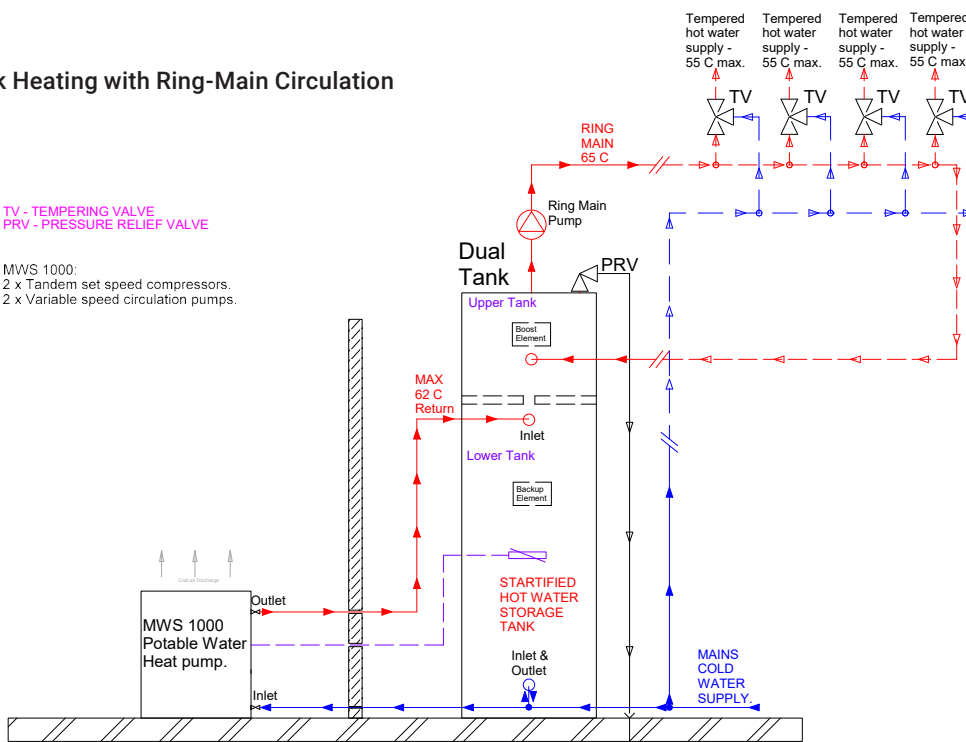



Heat Pump Water Heaters for Potable Applications

Appendix II

Storage Tank Specification

Temperzone Supplied

ALL DIMENSIONS IN mm UNLESS STATED OTHERWISE

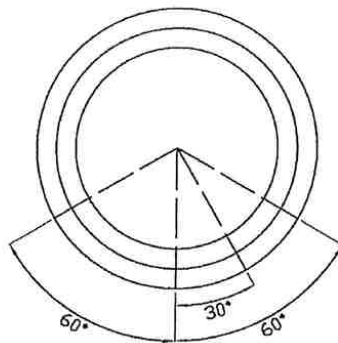

440/60LT 710Ø X 2070H MAINS PRESSURE HOT WATER CYLINDER TANKS ARE MADE USING HIGH QUALITY DUPLEX STAINLESS STEEL CASED IN A ZINCALUME OUTER CASE AND SUPER INSULATED HIGH DENSITY POLYURETHANE.

Representative Drawing Only
Design and Dimensions
controlled by Supplier

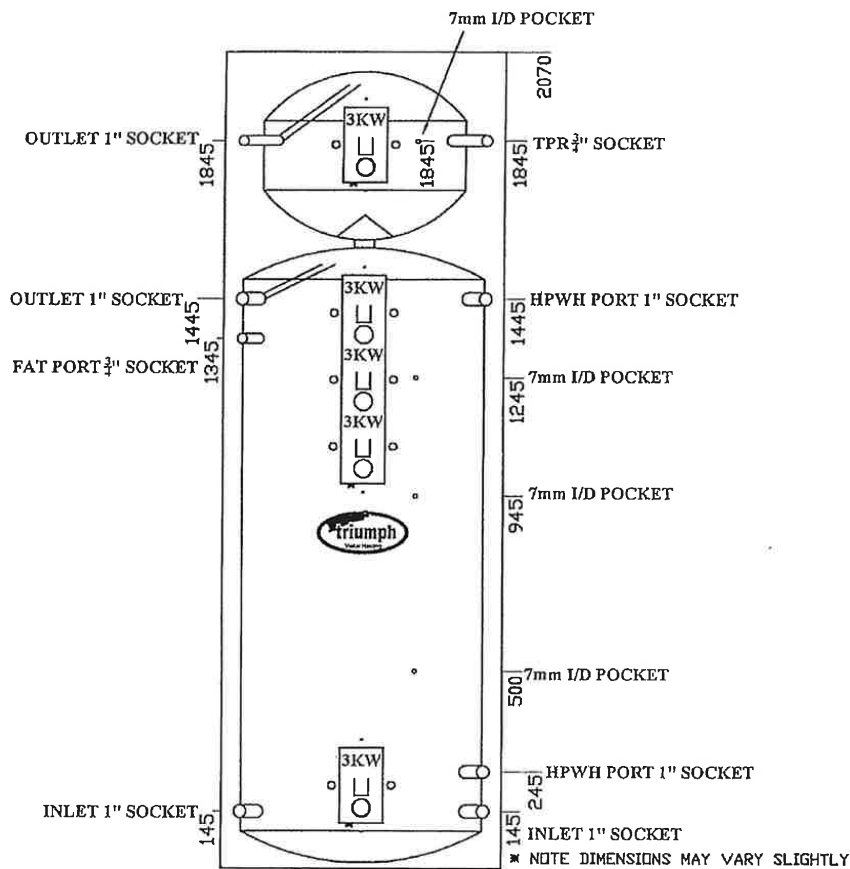



Heat Pump Water Heaters Single-Pass Potable

MWS Series

Notes

www.temperzone.biz

Auckland

Head Office

38 Tidal Rd, Mangere, Auckland
Private Bag 93303, Otahuhu
New Zealand

Email: sales@temperzone.co.nz

Phone: (09) 279 5250

Fax: (09) 275 5637

Sydney

Head Office

14 Carnegie Place, Blacktown
NSW 2148
PO Box 8064, Seven Hills West
NSW 2147, Australia

Email: sales@temperzone.com.au

Phone: (02) 8822 5700

Fax: (02) 8822 5711

Newcastle

Phone: (02) 4692 1155

Fax: (02) 4961 5101

Launceston

Phone: (03) 6331 4209

Fax: (03) 6333 0224

Hamilton

Phone: (07) 839 2705

Email: tzhamilton@temperzone.com

Adelaide

Phone: (08) 8115 - 2111

Fax: (08) 8115 2118

Singapore

Phone: +65 6733 4292

Fax: +65 6235 7180

Wellington

Phone: (04) 569 3262

Email: wgtn@temperzone.com

Melbourne

Phone: (03) 8769 7600

Fax: (03) 8769 7601

Christchurch

Phone: (03) 379 3216

Email: chch@temperzone.com

Brisbane

Phone: (07) 3308 8333

Fax: (07) 3308 8330

Perth

Phone: (08) 9314 3844

Fax: (08) 9314 3855

